

RoHS Compliant
Directive 2002/95/EC

SPECIFICATION

Customer: _____

Item:	CRYSTAL OSCILLATOR
Type:	NT3225SA
Output frequency:	16MHz
Customer's Spec. No.:	-----
NDK Spec. No.:	NSA0322A

Receipt

Charge:

Sales	NDK-I Paola Bandera	Tel. +39-02-96702920	Approved	T.Yamakawa
Engineer	Engineering Dept. 3 Y.Akasaka	Tel. +81-4-2900-6634	Checked	Y.Akasaka
			Drawn	Y.Akasaka

Revision Record

Rev.	Rev. Date	Items	Contents	Remarks
----	Dec. 03. 2007	Issue		

1. Type
NSA0322A
2. Rating
 - 2.1 Output frequency
16MHz with VCONT terminal grounded (2 digits marking)
Please refer to (Note) of drawing ETD14B-00755B
 - 2.2 Supply voltage
+3.0V DC (-Earth)
 - 2.3 Current consumption
1.5mA max.
 - 2.4 Output voltage
0.8Vp-p min. Clipped sine wave (DC-Coupling)
 - 2.5 Operating temp. Range
-40 to +85°C
 - 2.6 Storage temp. range
-50 to +105°C
 - 2.7 Load
10kΩ//10pF
 - 2.8 DC-cut capacitor
DC-cut capacitor of output is not put in VC-TCXO.
Please add DC-cut capacitor (1000pF) in output line.
3. Electrical specification
 - 3.1 Frequency stability
 - 3.1.1 Temp. variation of (-40 to +85°C)
±1ppm max. (Based on frequency at +25±2°C)
 - 3.1.2 Supply variation of (+3.0V ±5%)
±0.3ppm max.
 - 3.1.3 Load variation of (10kΩ//10pF)±10%
±0.2ppm max.
 - 3.1.4 Aging
±1.0ppm max. / year
4. Environmental specification
 - 4.1 Vibration
After the following test, shall meet electrical specification.
Test condition:
5 to 26Hz: 1.52mm (total amplitude)
26 to 500Hz: 19.6m/s²
20 minutes per 1 cycle
2 hours for each 3 planes
 - 4.2 Shock
After the following test, shall meet electrical specification.
Test condition:
980m/s², 6msec.
half sine
3 times for each 3 planes
 - 4.3 Drop test
After the following test, shall meet electrical specification.
Test condition:
1 drop onto hard wood board from 75cm height in each 3 planes.
 - 4.4 Humidity
After the following test, shall meet electrical specification.

Test condition:

+60°C, 95% RH for 48H

5. Reflow soldering

After the reflow soldering, frequency deviation shall meet within ± 1.0 ppm max.

Based on frequency before the reflow soldering.

Conditions of temperature profile (Refer to Fig.1)

Soldering peak temp. +260°C

6. Marking

(1) Abbreviation of manufacturer (N mark)

(2) Lot No.

(3) LR (Type identification number)

(4) Output frequency (MHz)

(5) Trace code

7. Inspection parameters

Para 2.1, 2.3, 2.4, 3.1.1, 6, 9.1 are inspected.

The other parameters are guaranteed to be within specified characteristics by NDK design.

Inspection data is not submitted for mass production lot. But only if requested, a copy of first lot production data will be submitted.

8. Precaution in the storage

Please keep the oscillator under below condition.

Temperature	+5°C to +45°C
Humidity	10% to 75% RH
Period	1year max

(table)

9. Application drawing

9.1 Dimension of External

ETD14B-00755B

9.2 Packing

ETK17B-00201

9.3 Land pattern

ETD15B-00010

10. Notice

10.1 When shipping, we will adjust output frequency within specification under the conditions mentioned below. (Fig.2)

10.2 Order items are manufactured according to specification. As to conditions, which are not indicated in this specification and unpredictable such as applied condition and oscillation margin, please check them beforehand.

10.3 Unless we receive request for modification within 3 weeks from the issue date of this NDK specification sheet, we will supply products according to this specification. Also, if you'd like to modify specification of order, which has been placed with delivery request within 3 weeks from the issue data of this specification sheet, we would like to discuss with you separately.

10.4 In no event shall the company be liable for any product failure resulting from an inappropriate handling or operation of the product beyond the scope of its guarantee.

10.5 Where any change to the process condition is made due to the change(s) in the production line, inform personnel of the specifications.

10.6 Should this specification data give rise to any disputes relating to any intellectual property rights or any other rights of a third person, the company shall not indemnify anyone for any damage.

Their disclosure must not be construed as the grant of a license to use any of the intellectual property rights owned by the company.

10.7 If you intend to use products listed on this specification for applications that may result in loss of life or assets (controls relating to safety, medical equipment, aeronautical equipment, space equipment, etc.), please do not fail to advise us of your intention beforehand.

10.8 In the company's production process whatever amount of ozone depleting substances (ODS) as specified in the Montreal protocol is not used.

10.9 Information contained in this specification must not be quoted, reproduced or used for other purposes including processing either in part or in full without obtaining prior approval from the company.

11. Prohibited items

Be sure to use the product under the following conditions. Otherwise, the characteristics deterioration or destruction of the product may result.

(1) Reflow soldering heat resistance

Peak temperature: +265°C

Heating: +225°C or higher, 90 sec

(2) Manual soldering heat resistance

Pressing a soldering iron of +410°C on the terminal electrode for five seconds.

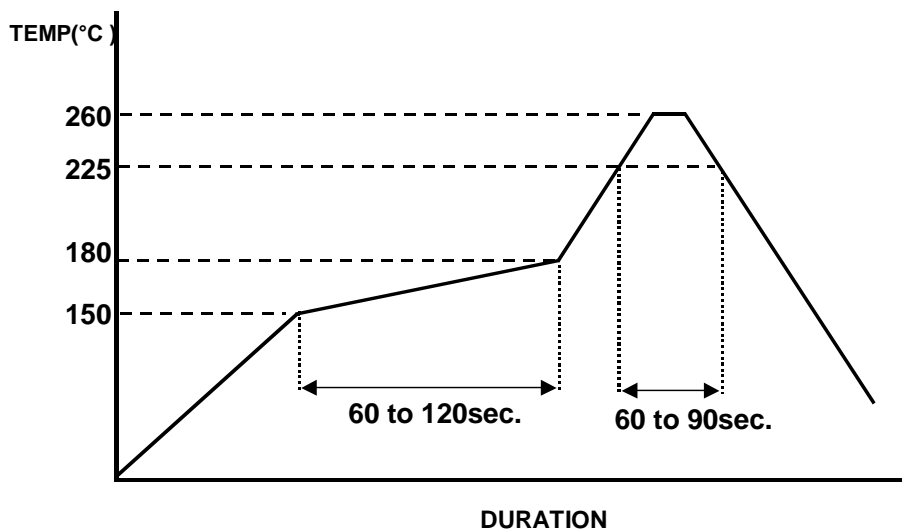

(Fig.1)

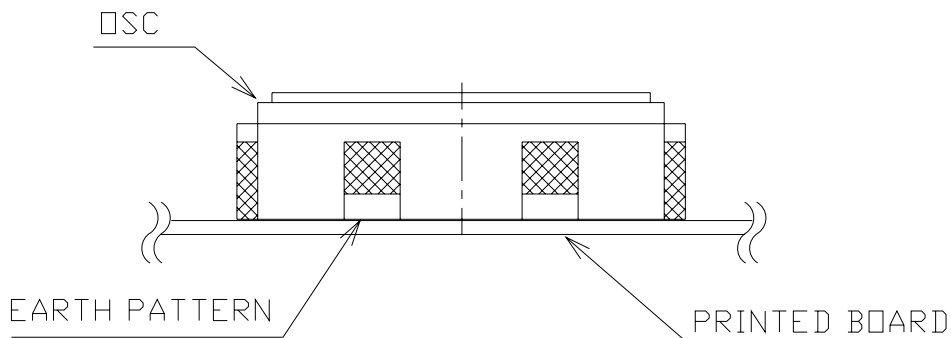

(Fig.2)

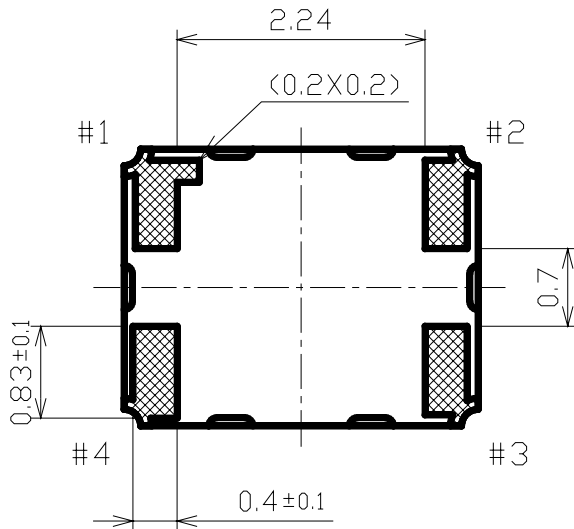
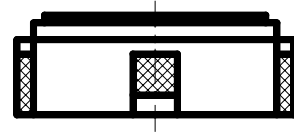
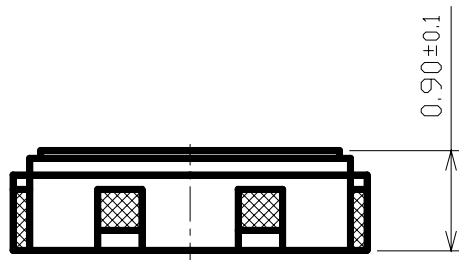
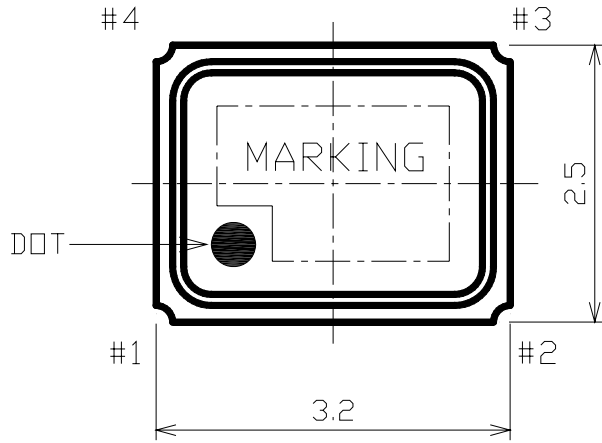

PIN CONNECTION	
#1	* VCONT
#2	GND
#3	OUTPUT
#4	VCC

*(Note)
Connect "VCONT" terminal to the ground on your circuit, otherwise oscillation frequency will shift from the output frequency specified.

Date of Revise	Charge	Approved	Reason		
B 27.Jul.2006	T.Abe	T.Yamakawa	The comment in a (note) is changed.		
Date	Name	Third Angle Projection	Tolerance	Scale	
Drawn 12.Oct.2004	H.Harima	Dimension:mm	+/- 0.2	15/1	
Designed -----	-----	Title	Drawing No.	Rev.	
Checked 12.Oct.2004	K.Moriya			B	
Approved 12.Oct.2004	Y.Narita				
		Dimension of External	ETD14B-00755		

NIHON DEMPA KOGYO CO., LTD.

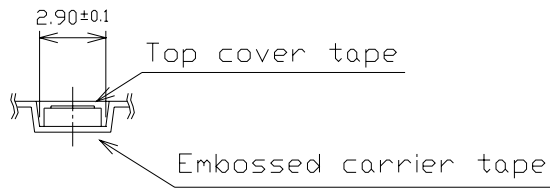
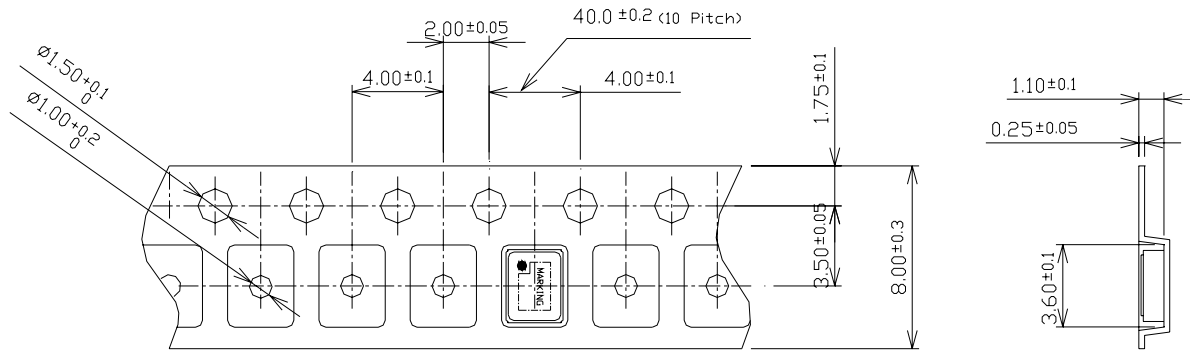

	Embossed carrier tape	Top cover tape
Materials	PS	PET + PE + Adhesive layer
Disposition	Antistatic	Antistatic

	Date of Revise	Charge	Approved	Reason	
A					
	Date	Name	Third Angle Projection	Tolerance	Scale
Drawn	5.Jun.2006	K. Moriya	Dimension:mm	----	3/1
Designed	5.Jun.2006	K. Moriya	Title	Drawing No.	Rev.
Checked	5.Jun.2006	K. Moriya			
Approved	5.Jun.2006	H. Mizumura			
			Packing	ETK17B-00201 (1/3)	

NIHON DEMPA KOGYO CO., LTD.

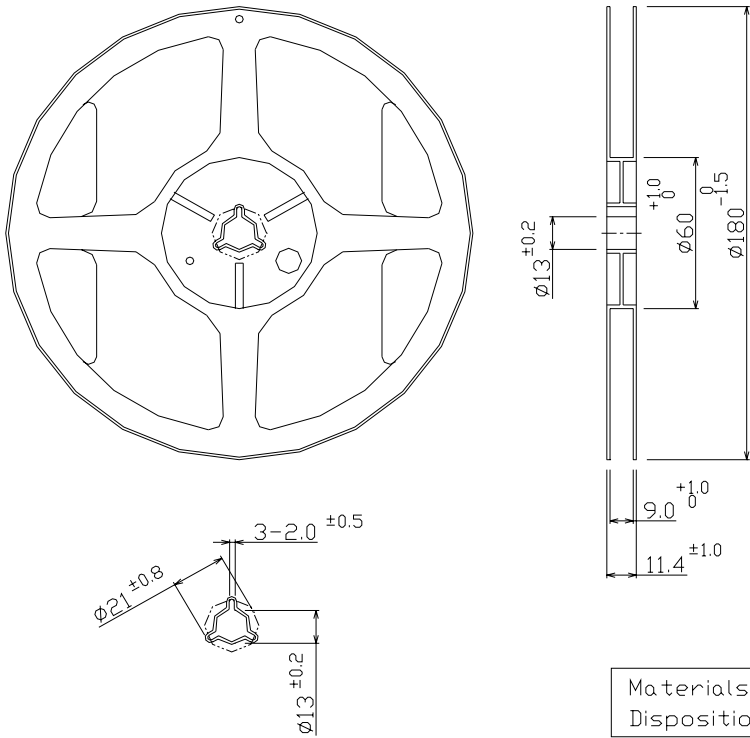

Materials : PS
Disposition : Antistatic

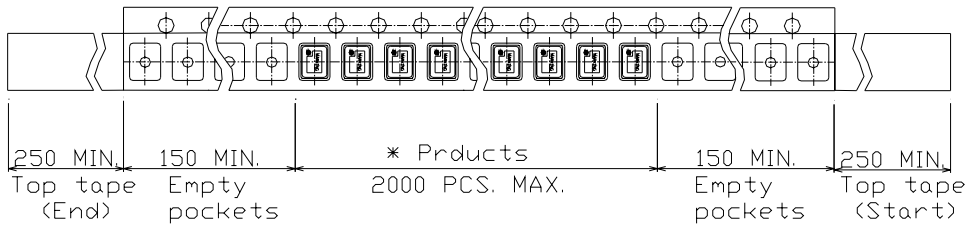

* There are no vacant pockets for this area.

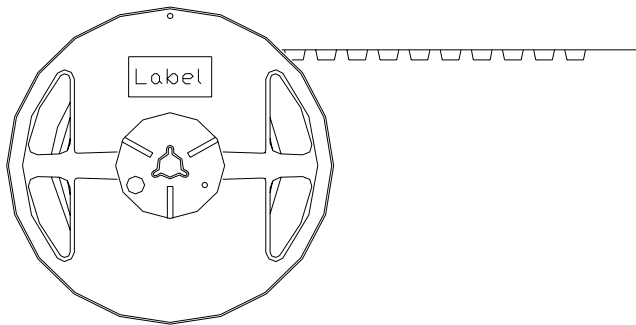

	Date of Revise	Charge	Approved	Reason	
A					
	Date	Name	Third Angle Projection	Tolerance	Scale
Drawn	5.Jun.2006	K. Moriya	Dimension:mm	-----	-----
Designed	5.Jun.2006	K. Moriya	Title	Drawing No.	Rev.
Checked	5.Jun.2006	K. Moriya			
Approved	5.Jun.2006	H. Mizumura			
			Packing	ETK17B-00201 (2/3)	

NIHON DEMPA KOGYO CO., LTD.

<Inner packing>

- 2000pcs.Max./ Reel
- 5 Reels Max./ Carton

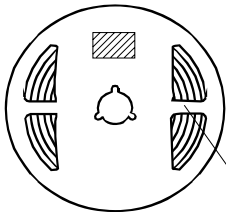

1

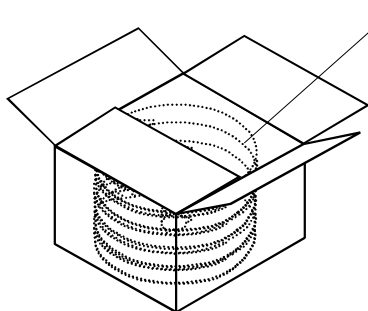

2

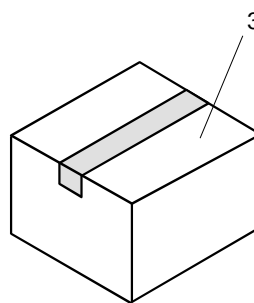

3

<Outer packing>

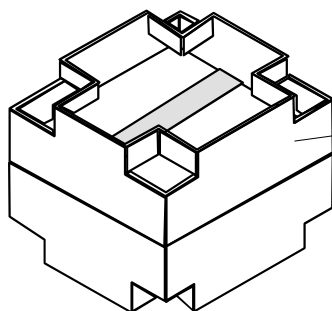

5

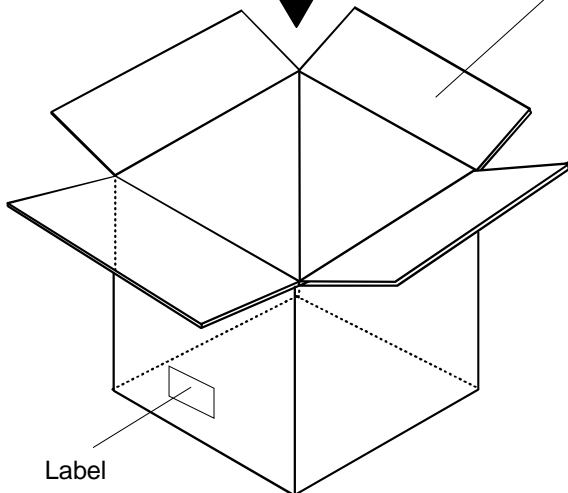

4

Label

No	Item	Materials
1	Reel	PS+Carbon(composite)
2	Spacer	Card board
3	Inner packing	Corrugated fiberboard
4	Outer packing	Corrugated fiberboard
5	Corner pad	Corrugated fiberboard

Date of Revise	Charge	Approved	Reason		
A					
Date	Name	Third Angle Projection	Tolerance	Scale	
Drawn 5.Jun.2006	K. Moriya	Dimension:mm	-----	-----	
Designed 5.Jun.2006	K. Moriya	Title	Drawing No.	Rev.	
Checked 5.Jun.2006	K. Moriya				
Approved 5.Jun.2006	H. Mizumura				
Packing			ETK17B-00201 (3/3)		

NIHON DEMPA KOGYO CO., LTD.

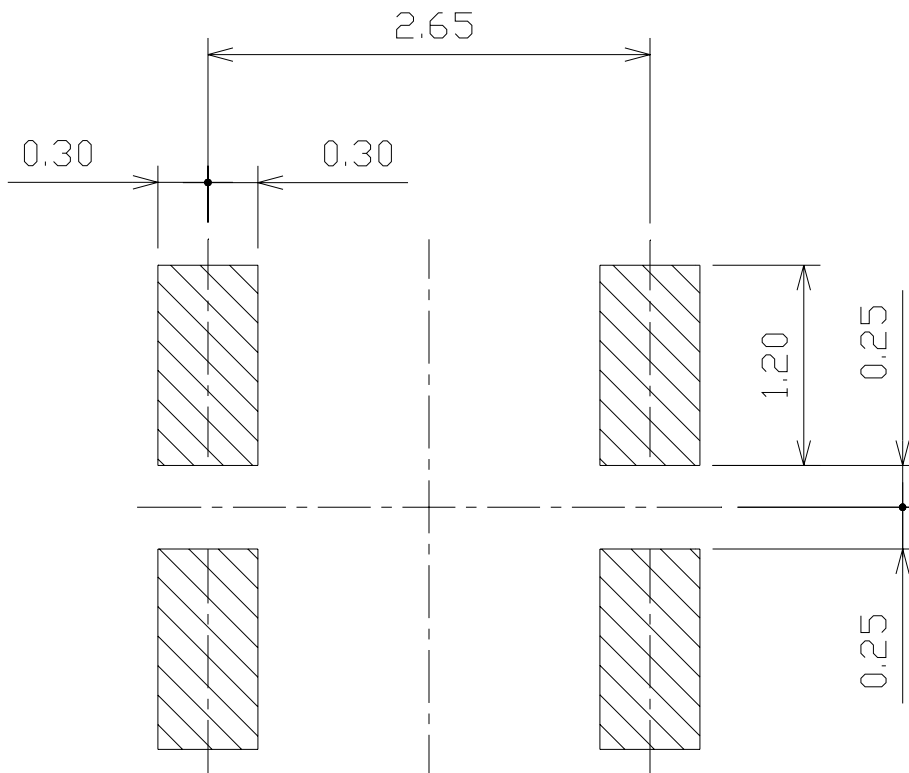

Note) Please reserve a large grand pattern on the PCB where the oscillator is installed.

	Date of Revise	Charge	Approved	Reason			
A							
	Date	Name	Third Angle Projection	Tolerance	Scale		
Drawn	4.Sep.2002	M. Fukunaga	Dimension:mm	-----	-----		
Designed	-----	-----	Title	Drawing No.	Rev.		
Checked	4.Sep.2002	K.Moriya			Land pattern	ETD15B-00010	
Approved	4.Sep.2002	H.Mizumura					

NIHON DEMPA KOGYO CO., LTD.