



SPECIFICATION

Customer: Eltech

Item:	CRYSTAL OSCILLATOR
Type:	NT3225SA
Nominal frequency:	16.384 MHz
Customer's Spec. No.:	-----
NDK Spec. No.:	END4112A

Receipt

Charge:

Sales	NDK-I Paola Bandera	Tel. +39-02-96702920	<u>Approved</u>	K.Moriya
Engineer	Engineering Dept. 3 A.Sakanashi	Tel. +81-4-2900-6634	<u>Checked</u>	M.Fukunga
			<u>Drawn</u>	A.Sakanashi

Revision Record				
Rev.	Rev. Date	Items	Contents	Remarks
-----	Mar.1.2010	Issue		

1. Type

NT3225SA

2. Rating

- 2.1 Nominal frequency
16.384 MHz (3 digits marking without the decimal point: 163)
- 2.2 Supply voltage
+3.3 V DC (-Earth)
- 2.3 Current consumption
Max. 1.5 mA
- 2.4 Output voltage
Min. 0.8 V_{p-p} Clipped sine wave (DC-Coupling)
- 2.5 Operating temp. range
-40 to +90 °C
- 2.6 Storage temp. range
-40 to +90 °C
- 2.7 Load impedance
10 kΩ//10 pF
- 2.8 DC-cut capacitor
DC-cut capacitor of output is not put in TCXO.
Please add DC-cut capacitor (1000 pF) in output line.

3. Electrical specification

- 3.1 Frequency stability
 - 3.1.1 Frequency/Temperature characteristics
Max. +/-2.0 ppm / -40 to +30 °C
Max. +/-0.5 ppm / -30 to +85 °C
Max. +/-1.5 ppm / +85 to +90 °C
(Based on frequency at +25 +/-2 °C)
 - 3.1.2 Frequency temperature slope
Max. +/-0.5 ppm/°C / -40 to -30 °C, +85 to +90 °C
Max. +/-0.3 ppm/°C / -30 to -20 °C, +75 to +85 °C
Max. +/-0.1 ppm/°C / -20 to +75 °C
(Minimum of one measurement every 2 °C)
 - 3.1.3 Frequency/Voltage coefficient
Max. +/-0.2 ppm / +3.3 V +/-0.1 V
 - 3.1.4 Frequency/Load coefficient
Max. +/-0.2 ppm / (10 kΩ//10 pF) +/-10 %
 - 3.1.5 Frequency tolerance at control voltage (V_{cont}) =+1.65 V DC
Max. +/-1.5 ppm (at +25 +/-2 °C, before reflow soldering, based on nominal frequency)
 - 3.1.6 Long-term frequency stability
Max. +/-1.0 ppm / year
- 3.2 External adjustment
 - 3.2.1 Control voltage (V_{cont})
+1.65 V +/-1.0 V DC
 - 3.2.2 Frequency control range based on frequency at V_{cont} =+1.65 V DC
Min. +/-7.0 ppm
 - 3.2.3 Frequency change polarity
Positive

4. Reflow soldering

- After the reflow soldering, frequency deviation shall meet within max +/-1.0 ppm.
Based on frequency before the reflow soldering.
Conditions of temperature profile (Refer to Fig.1)
Soldering peak temp. +260 °C

5. Marking

- (1) Abbreviation of manufacturer (N mark)
- (2) Lot No.
- (3) 20 (Type identification number)
- (4) Nominal frequency (MHz)
(The figures on the oscillator present the first 3 digits of the nominal frequency without the decimal point)
- (5) Trace code

6. Inspection parameters

Para 2.1, 2.3, 2.4, 3.1.1, 3.2.2, 5, 9.2 are inspected.

The other parameters are guaranteed to be within specified characteristics by NDK design.

Inspection data is not submitted for mass production lot. But only if requested, a copy of first lot production data will be submitted.

7. Precaution in the storage

Please keep the oscillator under below condition.

Temperature	+5 °C to +45 °C
Humidity	10 % to 75 % RH
Period	1year max

(table)

8. Frequency establishment condition

When output frequency is set, we suppose to have the ground pattern under the oscillator.

9. Application drawing

9.1 Reliability assurance item

ETS30B-00399

9.2 Dimension of External

ETD14B-00725D

9.3 Packing

ETK17B-00201B

9.4 Land pattern

ETD15B-00010

10. Notice

10.1 Order items are manufactured according to specification. As to conditions, which are not indicated in this specification and unpredictable such as applied condition and oscillation margin, please check them beforehand.

10.2 Unless we receive request for modification within 3 weeks from the issue date of this NDK specification sheet, we will supply products according to this specification. Also, if you'd like to modify specification of order, which has been placed with delivery request within 3 weeks from the issue data of this specification sheet, we would like to discuss with you separately.

10.3 In no event shall the company be liable for any product failure resulting from an inappropriate handling or operation of the product beyond the scope of its guarantee.

10.4 Where any change to the process condition is made due to the change(s) in the production line, inform personnel of the specifications.

10.5 Should this specification data give rise to any disputes relating to any intellectual property rights or any other rights of a third person, the company shall not indemnify anyone for any damage.

Their disclosure must not be construed as the grant of a license to use any of the intellectual property rights owned by the company.

10.6 If you intend to use products listed on this specification for applications that may result in loss of life or assets (controls relating to safety, medical equipment, aeronautical equipment, space equipment, etc.), please do not fail to advise us of your intention beforehand.

10.7 In the company's production process whatever amount of ozone depleting substances (ODS) as specified in the Montreal protocol is not used.

10.8 Information contained in this specification must not be quoted, reproduced or used for other purposes including processing either in part or in full without obtaining prior approval from the company.

11. Prohibited items

Be sure to use the product under the following conditions. Otherwise, the characteristics deterioration or destruction of the product may result.

(1) Reflow soldering heat resistance

Peak temperature: +265 °C

Heating: +225 °C or higher, 90 sec

(2) Manual soldering heat resistance

Pressing a soldering iron of +410 °C on the terminal electrode for five seconds.

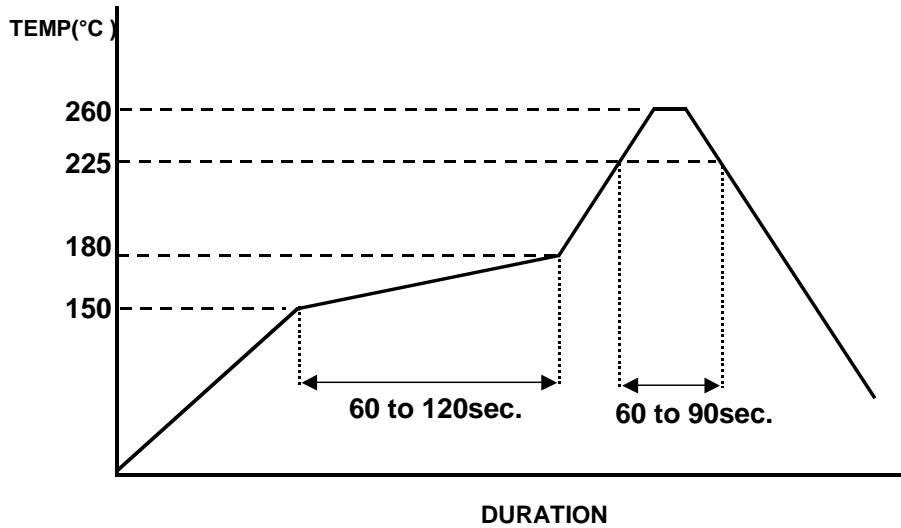

(Fig.1)

Reliability assurance item

(page: 1/1)

No.	Test Item	Test Methods	Specification Code
1	Vibration	5 to 26Hz: 1.52mm (total amplitude) 26 to 500Hz: 19.6m/s ² 20 minutes per 1 cycle. 2 hours for each 3 planes.	A
2	Shock	Half sine wave 6ms, 980 m/s ² . 3 times for each 3 planes.	A
3	Drop Test	Drop freely on the concrete from the height of 150cm With jig(150g). 3time for each 6 planes.	A
4	Humidity	+60°C, 95% RH for 48H. And normal temperature, with normal humidity for 24H.	A

Specification code	Specification
A	After the test, shall meet electrical specification.

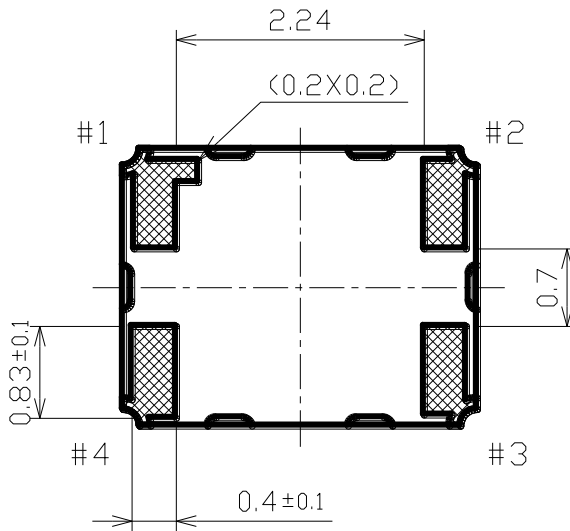
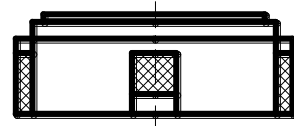
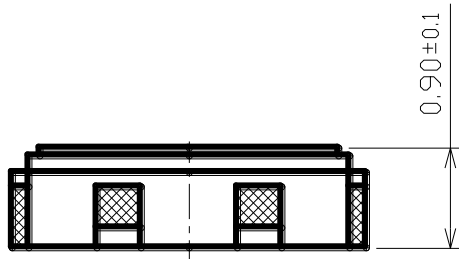
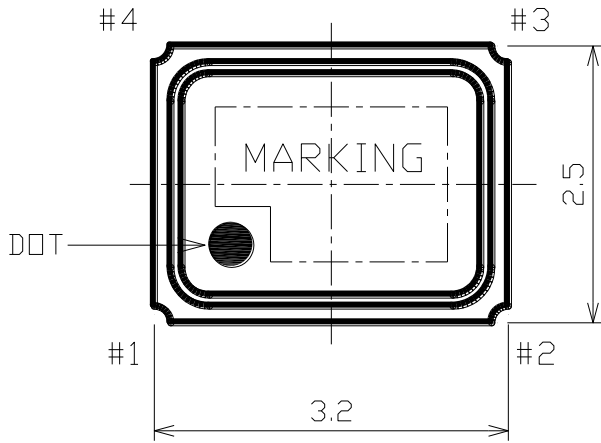

PAD No.	Connection
#1	VCONT
#2	GND
#3	OUTPUT
#4	VCC

Date of Revise	Charge	Approved	Reason		
D 18.Nov.2010	M.Kashiwamura	K.Moriya	Deletion of coplanarity spec.		
Date	Name	Third Angle Projection	Tolerance	Scale	
Drawn 22.Jul.2004	H.Harima	Dimension:mm	+/- 0.2	15/1	
Designed -----	-----	Title		Drawing No.	Rev.
Checked -----	-----	Dimension of External		ETD14B-00725	D
Approved 22.Jul.2004	Y.Narita				

NIHON DEMPA KOGYO CO., LTD.

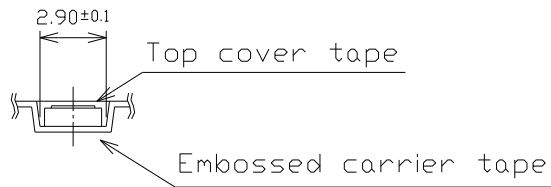
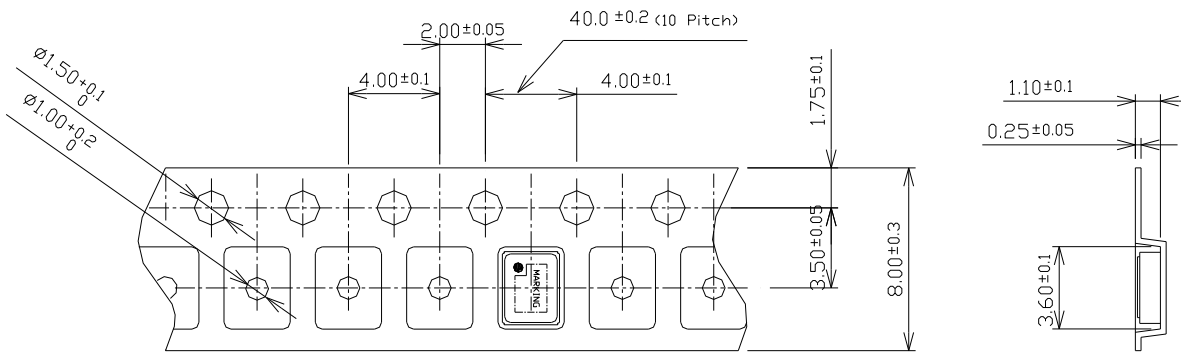

	Embossed carrier tape	Top cover tape
Materials	PS	PET + PE + Adhesive layer
Disposition	Antistatic	Antistatic

Date of Revise	Charge	Approved	Reason	
B 17.Jun.2008	S.Kawate	M.Kubota	Addition of Japanese	
Date	Name	Third Angle Projection	Tolerance	Scale
Drawn 5.Jun.2006	K. Moriya	Dimension:mm	-----	3/1
Designed 5.Jun.2006	K. Moriya	Title	Drawing No.	Rev.
Checked 5.Jun.2006	K. Moriya			
Approved 5.Jun.2006	H. Mizumura			
Packing			ETK17B-00201 (1/3)	B

NIHON DEMPA KOGYO CO., LTD.

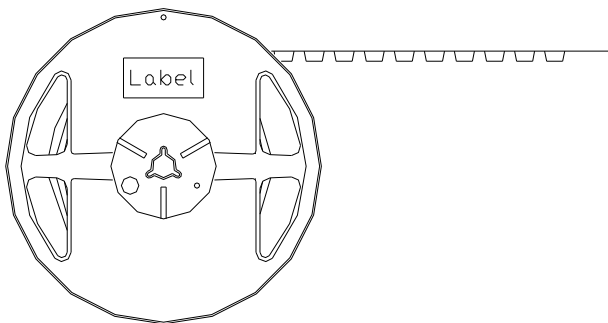
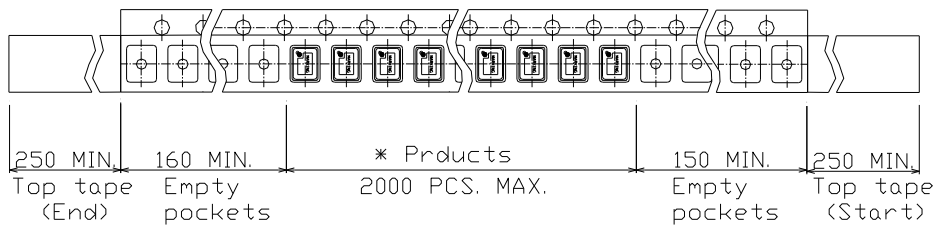
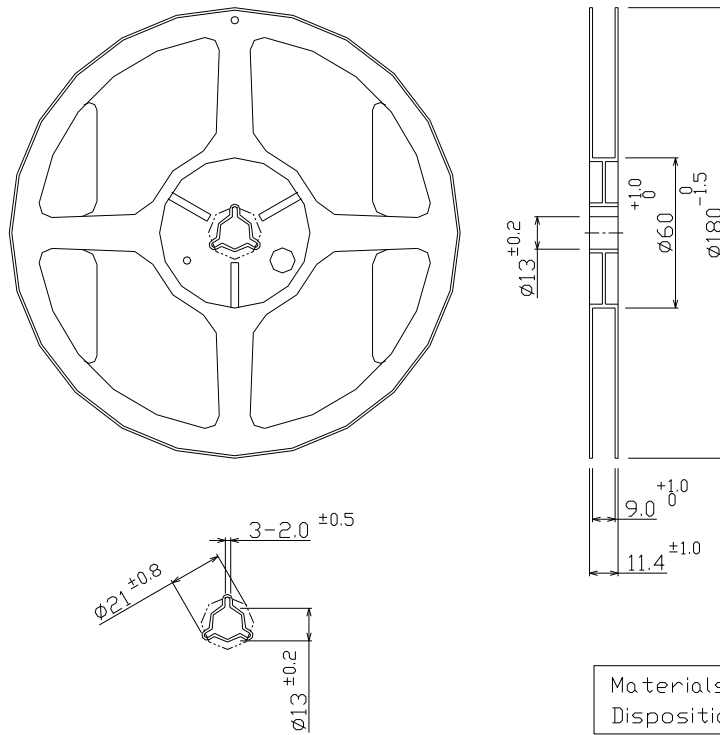

Date of Revise		Charge	Approved	Reason	
B					
	Date	Name	Third Angle Projection	Tolerance	Scale
Drawn	5.Jun.2006	K. Moriya	Dimension:mm	-----	-----
Designed	5.Jun.2006	K. Moriya	Title	Drawing No.	Rev.
Checked	5.Jun.2006	K. Moriya			
Approved	5.Jun.2006	H. Mizumura			
			Packing	ETK17B-00201 (2/3)	B

NIHON DEMPA KOGYO CO., LTD.

<Inner packing>

- 2000pcs.Max./ Reel
- 5 Reels Max./Carton

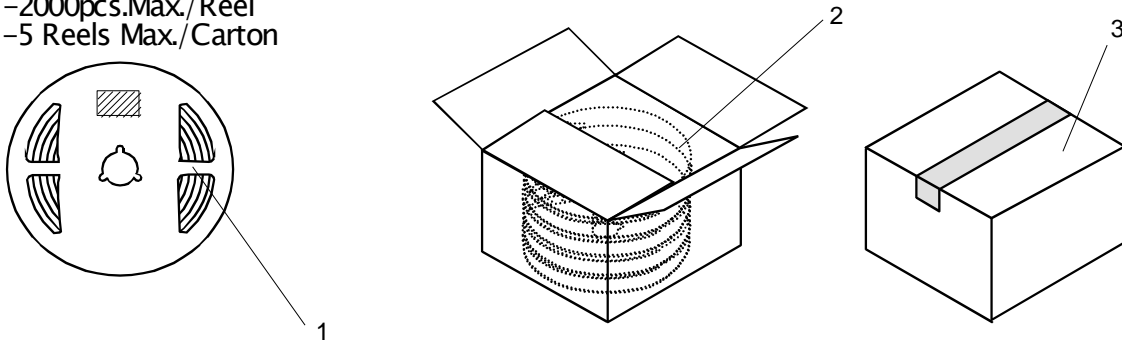

<Outer packing>

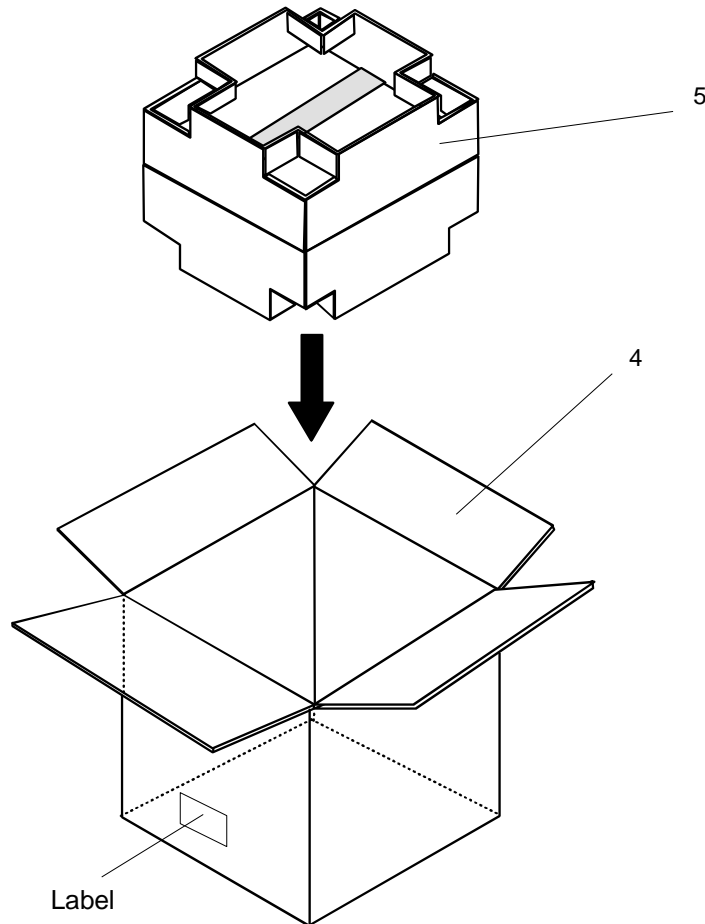

No	Item	Materials
1	Reel	PS+Carbon(composite)
2	Spacer	Card board
3	Inner packing	Corrugated fiberboard
4	Outer packing	Corrugated fiberboard
5	Corner pad	Corrugated fiberboard

Date of Revise		Charge	Approved	Reason		
B						
Drawn	Date	Name	Third Angle Projection	Tolerance	Scale	
5.Jun.2006	K. Moriya	Dimension:mm	-----	-----		
Designed	Date	Name	Title	Drawing No.	Rev.	
5.Jun.2006	K. Moriya	Packing			ETK17B-00201 (3/3)	B
5.Jun.2006	H. Mizumura					

NIHON DEMPA KOGYO CO., LTD.

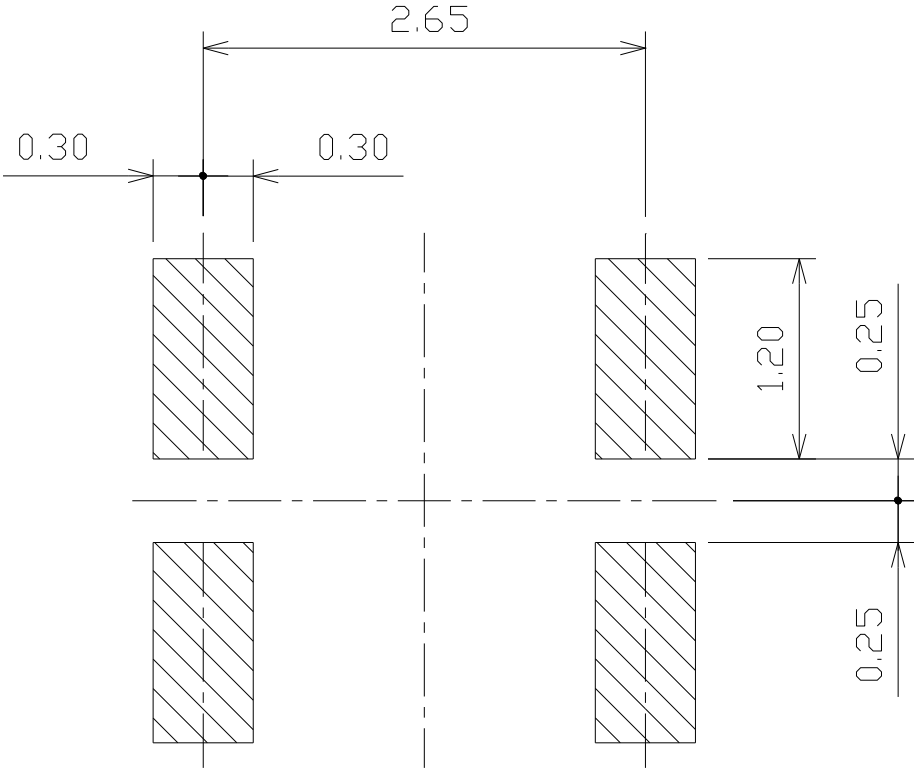

Note) Please reserve a large grand pattern on the PCB where the oscillator is installed.

	Date of Revise	Charge	Approved	Reason	
A					
	Date	Name	Third Angle Projection	Tolerance	Scale
Drawn	4.Sep.2002	M. Fukunaga	Dimension:mm	-----	-----
Designed	-----	-----	Title	Drawing No.	Rev.
Checked	4.Sep.2002	K.Moriya			
Approved	4.Sep.2002	H.Mizumura			
Land pattern			ETD15B-00010		

NIHON DEMPA KOGYO CO., LTD.