



SPECIFICATION

Customer: ELTECH COMPONENT LTD

Item:	CRYSTAL OSCILLATOR
Type:	NT3225SA
Nominal frequency:	14.4 MHz
Customer's Spec. No.:	---
NDK Spec. No.:	END5837A

Receipt

Revision Record						
Rev.	Date	Items	Contents	Approved	Checked	Drawn
-----	Jan. 10. 2020	Issue	---	T.Hosoda	S.Kawahara	S.Kawahara

1. Type NT3225SA

2. Maximum Rating

	Item	Rating	unit
1	Storage temp. range	-40 to +85	°C

3. Electrical specification

	Parameters	Electrical Spec.				Notes	
		Min.	Typ.	Max.	Units		
1	Nominal frequency		14.4		MHz		
2	Supply voltage (Vcc)	+3.13	+3.3	+3.47	V	(-Earth)	
3	Current consumption			1.5	mA		
4	Output voltage	0.8			Vp-p	Clipped sine wave (DC-Coupling)	
5	Operating temp. range	-40		+85	°C		
6	Load impedance (resistance part)	9	10	11	kΩ		
7	Load impedance (parallel capacitance)	9	10	11	pF		
8	DC-cut capacitor					DC-cut capacitor of output is not put in TCXO. Please add DC-cut capacitor (1000 pF) in output line.	
9	Frequency stability						
	1. Frequency /Temperature characteristics	-2.0		+2.0	ppm	-40 to +85 °C Based on frequency at +25+/-2 °C at control voltage (Vcont)=+1.5 V DC	
	2. Frequency/Voltage coefficient	-0.3		+0.3	ppm	+3.3 V +/-5 %	
	3. Frequency/Load coefficient	-0.2		+0.2	ppm	(10 kΩ//10 pF) +/-10 %	
	4. Frequency tolerance	-1.0		+1.0	ppm	at.+25+/-2 °C, Before reflow soldering, based on nominal frequency at control voltage (Vcont)=+1.5 V DC	
	5. Long-term frequency stability	-1.0		+1.0	ppm	Year(at.+25+/-2 °C)	
10	External adjustment						
	1. Control voltage (Vcont)	+0.5	+1.5	+2.5	V		
	2. Frequency control range	-8.0			ppm	Vcont= +0.5 V	based on frequency at Vcont+1.5 V DC
				+8.0	ppm		
	3. Modulation bandwidth	3			kHz	measured at -3 dB Vcont=+1.5 V DC	
	4. Linearity of frequency modulation deviation	-20		+20	%		
	5. Input impedance	500			kΩ		
6. Frequency change polarity					Positive		

	Parameters	Electrical Spec.				Notes
		Min.	Typ.	Max.	Units	
11	Harmonic distortion			-7.0	dBc	
12	Start-up time			2.0	ms	More than 90 % of final output voltage at +25+/-2 °C
13	Phase Noise		-94		dBc/Hz	@10 Hz offset
			-118		dBc/Hz	@100 Hz offset
			-139		dBc/Hz	@1 kHz offset
			-151		dBc/Hz	@10 kHz offset
			-153		dBc/Hz	@100 kHz offset

4. Reflow soldering

After 2 times reflow soldering, frequency deviation shall meet within max +/-1.0 ppm.

Based on frequency before the reflow soldering.

Conditions of temperature profile (Refer to Fig.1)

Soldering peak temp. +260 °C

5. Marking

(1) Abbreviation of manufacturer (N mark)

(2) Lot No.

(3) Nominal frequency (MHz)

(4) Trace code

6. Inspection parameters

Para 3.1, 3.3, 3.4, 3.9.1, 3.10.2, 5, 9.2 are inspected.

The other parameters are guaranteed to be within specified characteristics by NDK design.

Inspection data is not submitted for mass production lot. But only if requested, a copy of first lot production data will be submitted.

7. Precaution in the storage

When storing the product in high temperature and high humidity condition for a long time, product characteristics(solder ability etc.) and packaging condition may be deteriorated.

The product storage deadline is 1 year after delivery in unopened state. Please use within 1 year.

If you exceed 1 year please check the product characteristics etc, please use.

Please keep the oscillator under below condition.

MSL	Temperature	+5 °C to +45 °C
1	Humidity	10 % to 75 % RH
	Period	1 year max

(table)

8. Frequency establishment condition

When output frequency is set, we suppose to have the ground pattern under the oscillator.

9. Application drawing

- 9.1 Reliability assurance item
ETS30B-00399
- 9.2 Dimension of External
ETD14B-00725F
- 9.3 Packing
ETK17B-00299A
- 9.4 Land pattern
ETD15B-00010A
- 9.5 Marking
ETH11B-00445B

10. Notes on use

10.1 This product cannot be used for automotive applications.

10.2 IN THE CASE OF THE FOLLOWING ITEMS, WE ARE NOT RESPONSIBLE FOR WARRANTY / COMPENSATION.

(1) WHEN PRODUCTS OF THIS SPECIFICATION ARE USED FOR EQUIPMENT RELATED TO HUMAN LIFE OR PROPERTY, IT IS THE RESPONSIBILITY OF THE CUSTOMER TO CONFIRM THE INFLUENCE ON THIS PRODUCT AND EQUIPMENT TO BE USED BEFOREHAND, CONDUCT NECESSARY SAFETY DESIGN (INCLUDING REDUNDANT DESIGN, MALFUNCTION PREVENTION DESIGN, ETC.), PLEASE USE IT AFTER SECURING SUFFICIENT SAFETY OF EQUIPMENT.

- 1. SAFETY-RELATED EQUIPMENT SUCH AS AUTOMOBILES, TRAINS, SHIPS, ETC., OR EQUIPMENT DIRECTLY INVOLVED IN OPERATION
- 2. AIRCRAFT EQUIPMENT
- 3. SPACE EQUIPMENT
- 4. MEDICAL EQUIPMENT
- 5. MILITARY EQUIPMENT
- 6. DISASTER PREVENTION / CRIME PREVENTION EQUIPMENT
- 7. TRAFFIC LIGHT
- 8. OTHER EQUIPMENT REQUIRING THE SAME PERFORMANCE AS THE ABOVE-MENTIONED EQUIPMENT

(2) IN CASES WHERE IT IS NOT INDICATED IN THE REQUESTED STANDARD AND IS USED UNDER CONDITIONS OF USE (INCLUDING CIRCUIT MARGIN ETC.) THAT CANNOT BE PREDICTED AT THE PRODUCTION STAGE.

(3) WHEN USING ULTRASONIC WELDING MACHINE. (THERE IS A POSSIBILITY THAT THE CHARACTERISTIC DEGRADATION IS CAUSED BY THE RESONANCE PHENOMENON OF THE CRYSTAL PIECE.)

(4) USING RESIN MOLD MAY AFFECT THE PRODUCT CHARACTERISTIC.

PLEASE MAKE SURE TO TELL OUR SALES CONTACT WHEN YOU USE RESIN MOLD. WE WILL PERFORM INDIVIDUAL CORRESPONDENCE ABOUT A DELIVERY SPECIFICATION AND A EVALUATION METHOD.

IN ADDITION, IF YOU USE RESIN MOLD WITHOUT CONTACTING US, AND CAUSES DAMAGES AGAINST A CUSTOMER OR A THIRD PARTY, WE WILL NOT BE LIABLE FOR THE DAMAGES AND OTHER RESPONSIBILITIES BECAUSE WE CONSIDER IT IS UNDER SELF-RESPONSIBILITY USING RESIN MOLD.

- WE WILL NOT TAKE ANY RESPONSIBILITY FOR THE INFLUENCE OF THE CUSTOMERS' PROCESS.

PLEASE EFFICIENTLY EVALUATE AT A SAMPLE STEP WHEN YOU USE RESIN MOLD.

(5) OPERATION IN HIGH HUMIDITY OR CONDENSATION CONDITIONS WILL AFFECT THE CHARACTERISTICS. IF SUCH ENVIRONMENT USE, PLEASE TAKE MEASURES AGAINST WATERPROOF.

(6) WHEN PERFORMING IMPROPER HANDLING THAT EXCEEDS THE GUARANTEED RANGE.

10.3 Even if the appearance color etc. of the product differs by purchasing the component parts by more than two companies, there is no influence on the characteristics and reliability.

11. Other Requests

11.1 Please use this specification only for confirmation of the specification of this product.

11.2 If there is a change request, please contact within three weeks from issue date. If there is no communication, we will deliver the product under the contents of this specification.

In addition, if the product delivery date is within 3 weeks and there is a change request, we will consult the processing separately.

11.3 NOTES THAT ARE DESCRIBED IN THIS DOCUMENT, IF YOU DID NOT COMPLY WITH THE PROHIBITIONS, AND OTHER PLEASE, INCLUDING THE FAILURE CORRESPONDENCE OR COMPENSATION OR DAMAGES, WE CANNOT ASSUME THE RESPONSIBILITY, PLEASE UNDERSTAND.

12. Prohibited items

Be sure to use the product under the following conditions. Otherwise, the characteristics deterioration or destruction of the product may result.

- (1) Reflow soldering heat resistance
Peak temperature: +265 °C
Heating: +225 °C or higher, 90 sec
- (2) Manual soldering heat resistance
Pressing a soldering iron of +350 +/-5 °C on the terminal electrode for 3+/-1 seconds.
- (3) Hot air heat resistance
Blow hot air of +350 +/-5 °C on the product for 3+/-1 seconds.

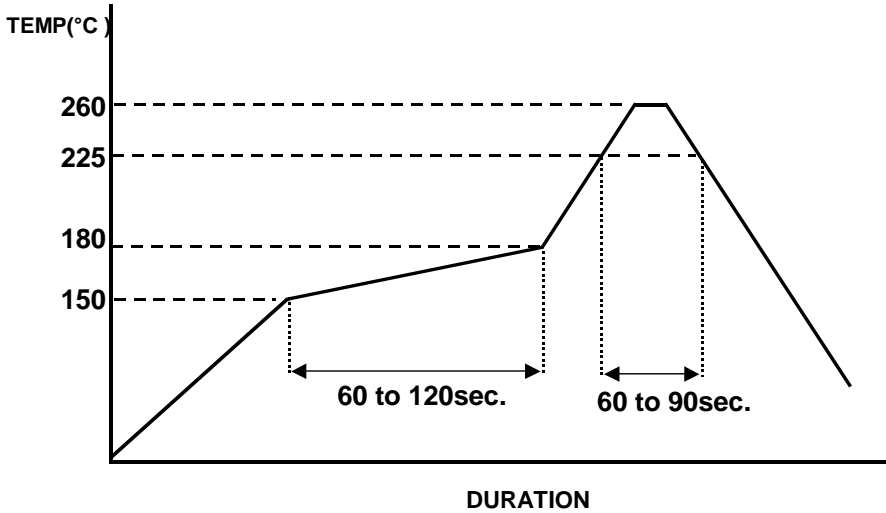

(Fig.1)

Reliability assurance item

(page: 1/1)

No.	Test Item	Test Methods	Specification Code
1	Vibration	5 to 26Hz: 1.52mm (total amplitude) 26 to 500Hz: 19.6m/s ² 20 minutes per 1 cycle. 2 hours for each 3 planes.	A
2	Shock	Half sine wave 6ms, 980 m/s ² . 3 times for each 3 planes.	A
3	Drop Test	Drop freely on the concrete from the height of 150cm With jig(150g). 3time for each 6 planes.	A
4	Humidity	+60°C, 95% RH for 48H. And normal temperature, with normal humidity for 24H.	A

Specification code	Specification
A	After the test, shall meet electrical specification.

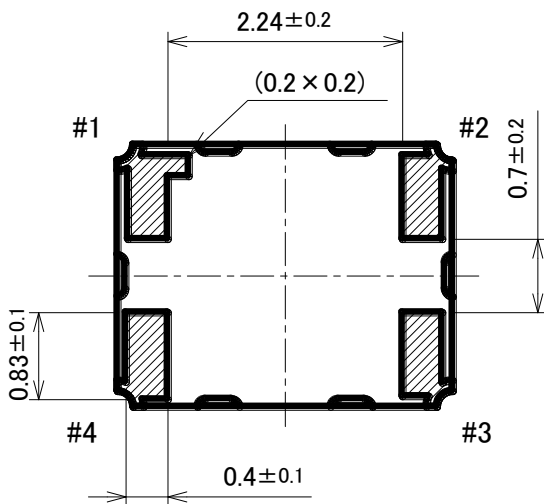
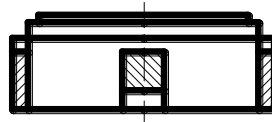
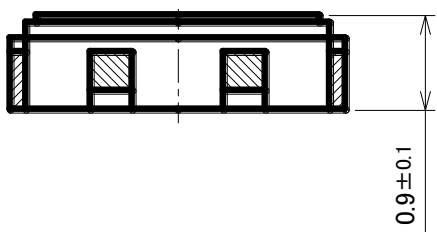
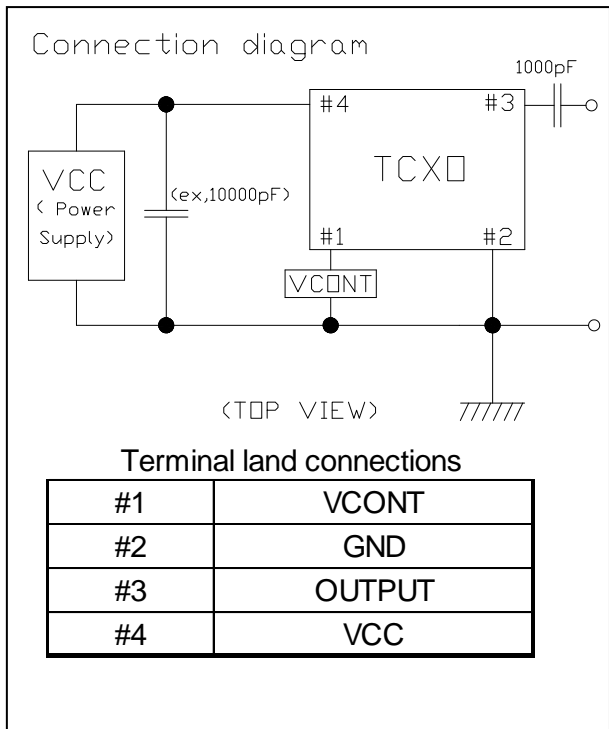
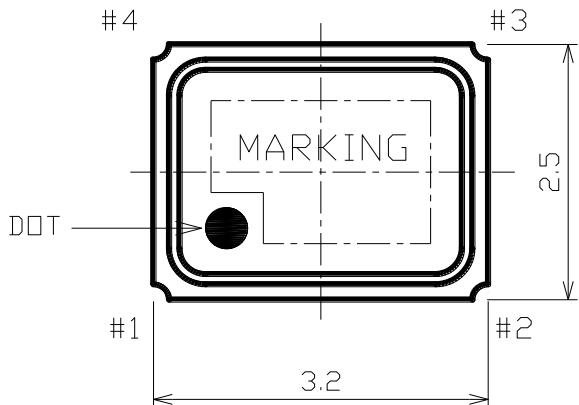

	Date of Revise	Charge	Approved	Reason
F	1.Jul.2013	E.Hoshi	K.Moriya	English Additional
	Date	Name	Third Angle Projection	Tolerance
Drawn	22.Jul.2004	H.Harima	Dimension:mm	+/- 0.2
Designed	-----	-----	Title	Drawing No.
Checked	-----	-----		
Approved	11.Jun.2013	K.Moriya		
			Dimension of External	ETD14B-00725
				Rev.
				F

NIHON DEMPA KOGYO CO., LTD.

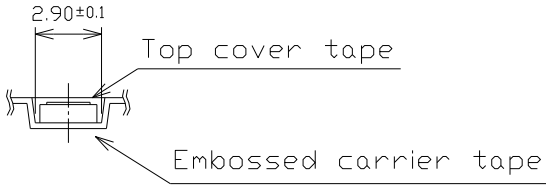
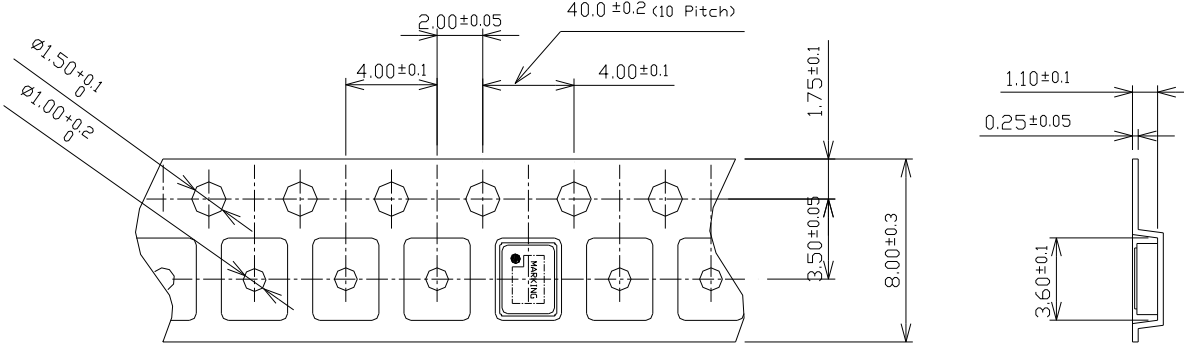

	Embossed carrier tape	Top cover tape
Materials	PS	PET + PE + Adhesive layer
Disposition	Antistatic	Antistatic

	Date of Revise	Charge	Approved	Reason	
A	18.Nov.2010	R.Yoshizaki	K.Moriya	Amount addition	
	Date	Name	Third Angle Projection	Tolerance	Scale
Drawn	19.May.2010	M.Kashiwamura	Dimension:mm	----	3/1
Designed	19.May.2010	M.Kashiwamura	Title	Drawing No.	Rev.
Checked	19.May.2010	K. Moriya			
Approved	19.May.2010	K. Moriya			
			Packing	ETK17B-00299 (1/3)	A

NIHON DEMPA KOGYO CO., LTD.

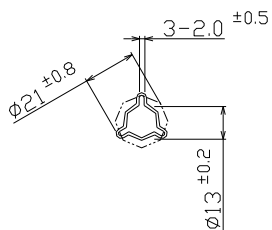
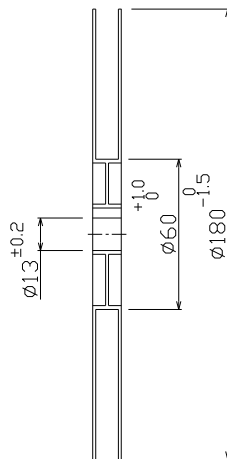
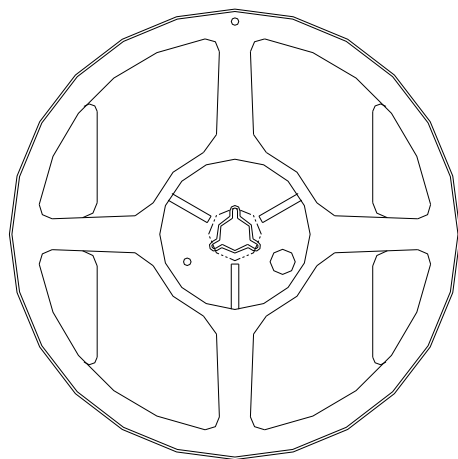

Materials : PS
Disposition : Antistatic

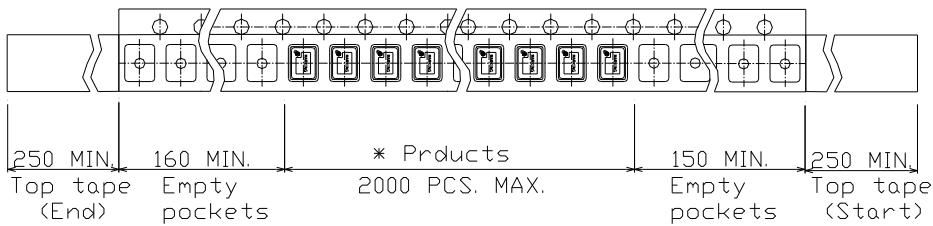

* There are no vacant pockets for this area.

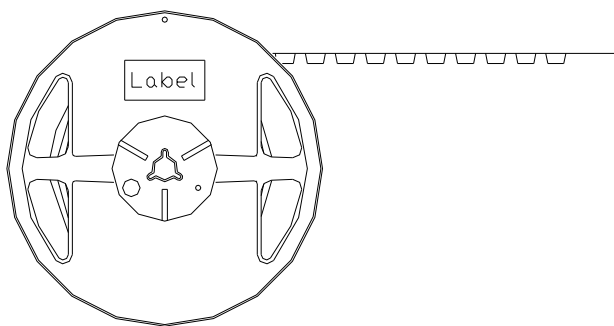

	Date of Revise	Charge	Approved	Reason	
A					
	Date	Name	Third Angle Projection	Tolerance	Scale
Drawn	19.May.2010	M.Kashiwamura	Dimension:mm	-----	-----
Designed	19.May.2010	M.Kashiwamura	Title	Drawing No.	Rev.
Checked	19.May.2010	K. Moriya			
Approved	19.May.2010	K. Moriya			
Packing			ETK17B-00299 (2/3)		A

NIHON DEMPA KOGYO CO., LTD.

-2000pcs.Max./Reel
 -5 Reels Max./Carton

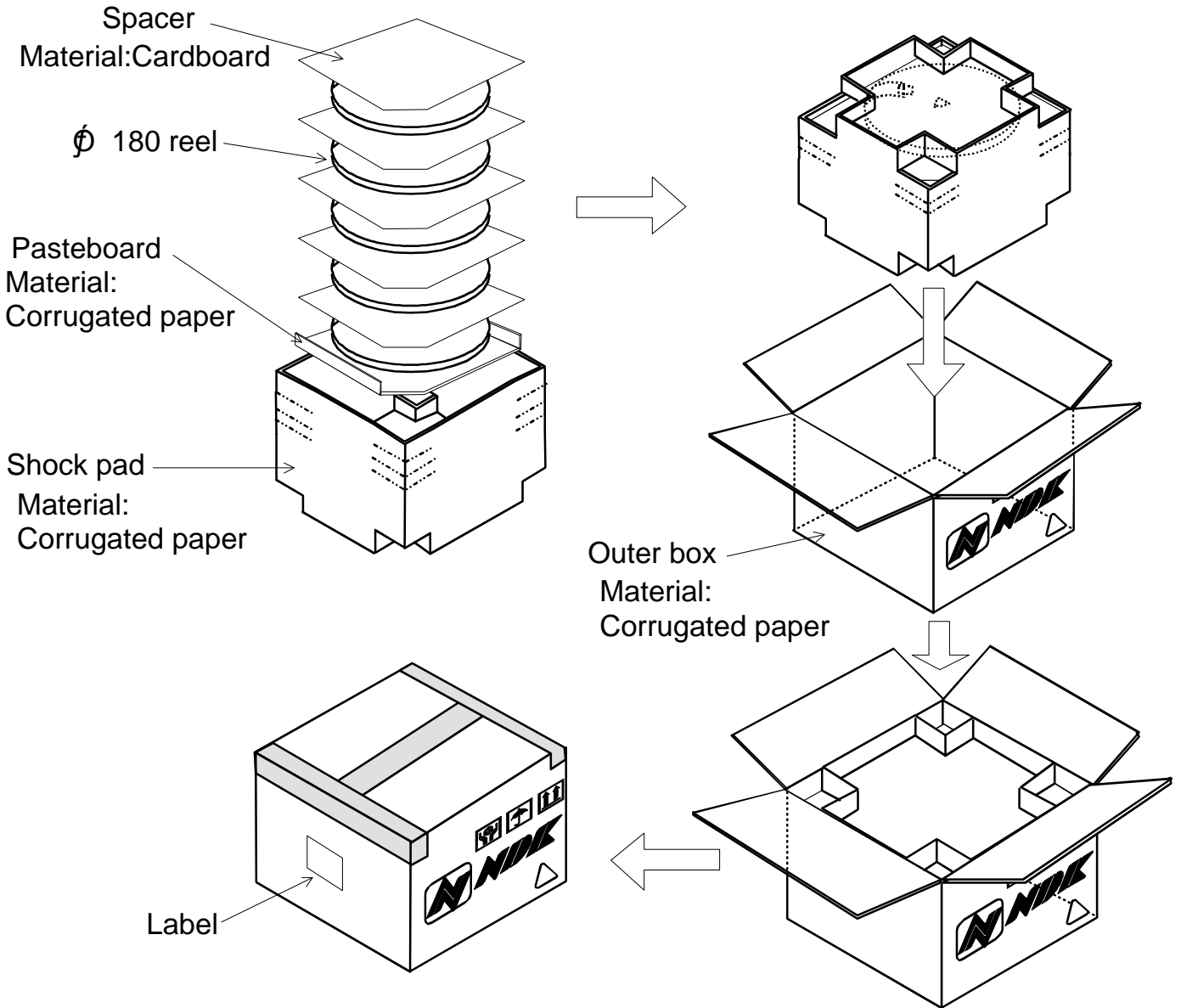

	Date of Revise	Charge	Approved	Reason	
A					
	Date	Name	Third Angle Projection	Tolerance	Scale
Drawn	19.May.2010	M.Kashiwamura	Dimension:mm	----	----
Designed	19.May.2010	M.Kashiwamura	Title	Drawing No.	Rev.
Checked	19.May.2010	K. Moriya			
Approved	19.May.2010	K. Moriya			
			Packing	ETK17B-00299 (3/3)	A

NIHON DEMPA KOGYO CO., LTD.

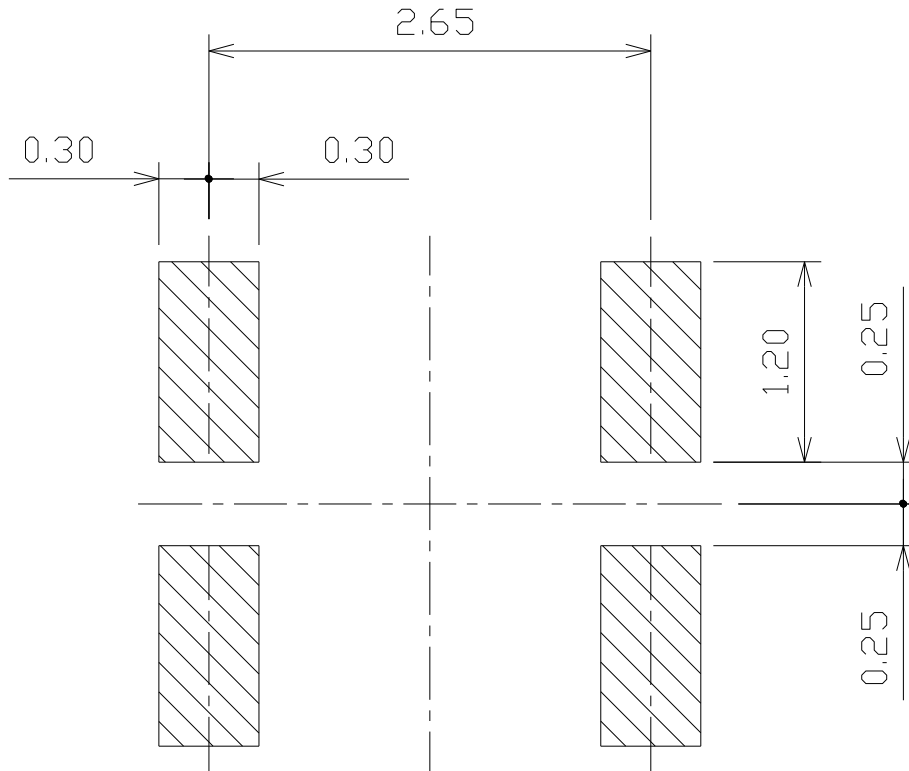

Note) Please reserve a large ground pattern on the PCB where the oscillator is installed.

	Date of Revise	Charge	Approved	Reason	
A	17. Nov. 2011	A.Fujii	K.Moriya	Note change	
	Date	Name	Third Angle Projection	Tolerance	Scale
Drawn	4.Sep.2002	M. Fukunaga	Dimension:mm	-----	-----
Designed	-----	-----	Title	Drawing No.	Rev.
Checked	4.Sep.2002	K.Moriya			
Approved	4.Sep.2002	H.Mizumura			
			Land pattern	ETD15B-00010	A

NIHON DEMPA KOGYO CO., LTD.

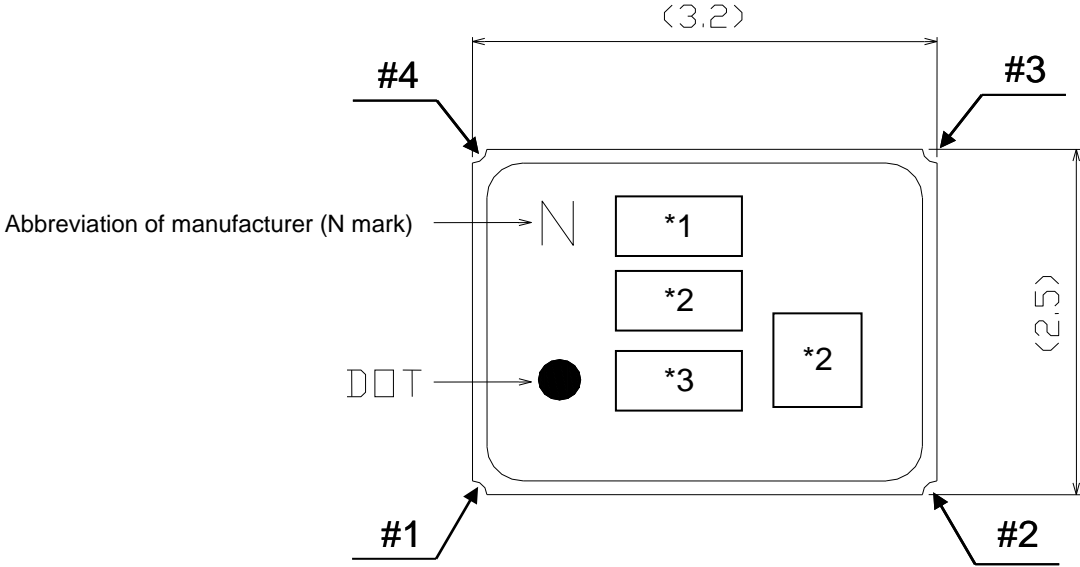

Terminal land connections: Please refer to “Dimension of External”.

(Marking Contents)

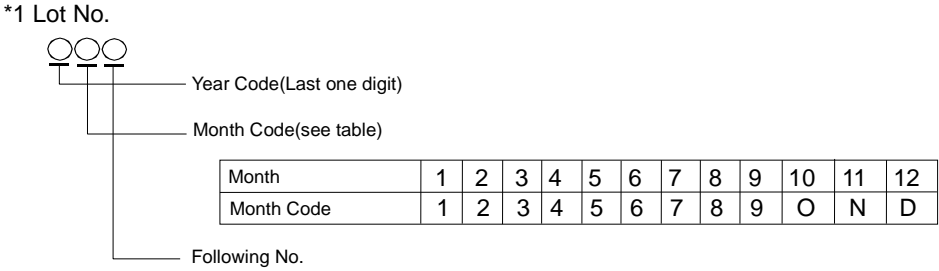

*2 Trace code
Trace code indicate production date and production line number.

*3 Nominal Frequency
 - A unit (MHz) is not written.
 - A decimal point omits.
 (Example : (2digits) 26MHz → 26 , (3digits) 19.2MHz → 192, (4more digits) 16.368MHz → 163)

Marking Method : Laser Trimming

	Date of Revise	Charge	Approved	Reason	
B	4. Mar. 2015	E.Hoshi	A.Konda	Clerical error Correction	
	Date	Name	Third Angle Projection	Tolerance	Scale
Drawn	17. Apr. 2013	R.Yoshizaki	Dimension:mm	---	---
Designed	17. Apr. 2013	R.Yoshizaki	Title	Drawing No.	Rev.
Checked	17. Apr. 2013	M.Kashiwamura			
Approved	17. Apr. 2013	K. Moriya			
			Marking	ETH11B-00445	B

NIHON DEMPA KOGYO CO., LTD.