



SPECIFICATION

Customer: ELTECH

Item:	CRYSTAL OSCILLATOR
Type:	NT2520SB
Nominal frequency:	24 MHz
Customer's Spec. No.:	-----
NDK Spec. No.:	END4600C

Receipt

Charge:

Sales	NDK-I Paola Bandera	Tel. +39-02-96702920	<u>Approved</u>	A.Konda
Engineer	Engineering Dept. 3 R.Yoshizaki	Tel. +81-4-2900-6634	<u>Checked</u>	A.Konda
			<u>Drawn</u>	R.Yoshizaki

Revision Record				
Rev.	Rev. Date	Items	Contents	Remarks
----	Oct. 10. 2013	Issue		

1. Type

NT2520SB

2. Rating

- 2.1 Nominal frequency
24 MHz (2 digits marking)
- 2.2 Supply voltage
+2.8 V +/-5 % DC (-Earth)
- 2.3 Current consumption
Max. 2.0 mA
- 2.4 Output voltage
Min. 0.8 V_{p-p} Clipped sine wave (DC-Coupling)
- 2.5 Operating temp. range
-40 to +85 °C
- 2.6 Storage temp. range
-40 to +85 °C
- 2.7 Load impedance
10kΩ // 10pF
- 2.8 DC-cut capacitor
DC-cut capacitor of output is not put in TCXO.
Please add DC-cut capacitor (1000pF) in output line.

3. Electrical specification

- 3.1 Frequency stability
 - 3.1.1 Frequency/Temperature characteristics
Max. +/-0.5 ppm / -40 to +85 °C
(Based on frequency at +25+/-2 °C)
 - 3.1.2 Frequency/Voltage coefficient
Max. +/-0.2 ppm / +2.8 V +/-5 %
 - 3.1.3 Frequency/Load coefficient
Max. +/-0.2 ppm / (10 kΩ // 10 pF) +/-10 %
 - 3.1.4 Frequency tolerance
Max. +/-2.0 ppm (at +25+/-2 °C, before reflow soldering, based on nominal frequency)
 - 3.1.5 Long-term frequency stability
Max. +/-1.0 ppm / year

4. Reflow soldering

After the reflow soldering, frequency deviation shall meet within max +/-1.0 ppm.
Based on frequency before the reflow soldering.
Conditions of temperature profile (Refer to Fig.1)
Soldering peak temp. +260 °C

5. Marking

- (1) Manufacture Name(NDK symbol mark)
- (2) Trace code
- (3) Nominal frequency (MHz)
- (4) Lot No.

6. Inspection parameters

Para 2.1, 2.3, 2.4, 3.1.1, 5, 10.2 are inspected.
The other parameters are guaranteed to be within specified characteristics by NDK design.
Inspection data is not submitted for mass production lot. But only if requested, a copy of first lot production data will be submitted.

7. Precaution in the storage

Please keep the oscillator in the ordinary temperature and humidity that are suggested as below table.

	Before taking out of dry bag	After taking out of dry bag
Temperature	+5 °C to +45 °C	+30 °C max.
Humidity	10 % to 75 % RH	70 % max.
Period	6 months	168 hours *

(table)

* It is desirable for the oscillator to be used within 168 hours after taking out of dry bag. Please pack the oscillator into used dry bag with a desiccant and seal it up by heat sealer etc. In case the heat sealer is not available, sealing up with cellophane tape or a vinyl tape will do.

8. Frequency establishment condition

When output frequency is set, we suppose to have the ground pattern under the oscillator.

9. Washing

Not available for washing.

10. Application drawing

10.1 Reliability assurance item

ETS30B-00399

10.2 Dimension of External

ETD14B-01474B

10.3 Packing

ETK17B-00301A

10.4 Land pattern

ETD15B-00022A

11. Notice

- 11.1 Order items are manufactured according to specification. As to conditions, which are not indicated in this specification and unpredictable such as applied condition and oscillation margin, please check them beforehand.
- 11.2 Unless we receive request for modification within 3 weeks from the issue date of this NDK specification sheet, we will supply products according to this specification. Also, if you'd like to modify specification of order, which has been placed with delivery request within 3 weeks from the issue data of this specification sheet, we would like to discuss with you separately.
- 11.3 In no event shall the company be liable for any product failure resulting from an inappropriate handling or operation of the product beyond the scope of its guarantee.
- 11.4 Where any change to the process condition is made due to the change(s) in the production line, inform personnel of the specifications.
- 11.5 Should this specification data give rise to any disputes relating to any intellectual property rights or any other rights of a third person, the company shall not indemnify anyone for any damage. Their disclosure must not be construed as the grant of a license to use any of the intellectual property rights owned by the company.
- 11.6 If you intend to use products listed on this specification for applications that may result in loss of life or assets (controls relating to safety, medical equipment, aeronautical equipment, space equipment, etc.), please do not fail to advise us of your intention beforehand.
- 11.7 In the company's production process whatever amount of ozone depleting substances (ODS) as specified in the Montreal protocol is not used.
- 11.8 Information contained in this specification must not be quoted, reproduced or used for other purposes including processing either in part or in full without obtaining prior approval from the company.
- 11.9 If you use resin for fixing components during manufacturing, please keep resin from adhering to the oscillator.

12. Prohibited items

Be sure to use the product under the following conditions. Otherwise, the characteristics deterioration or destruction of the product may result.

(1) Reflow soldering heat resistance

Peak temperature: +265°C

Heating: +225°C or higher, 90 sec

(2) Manual soldering heat resistance

Pressing a soldering iron of +410°C on the terminal electrode for five seconds.

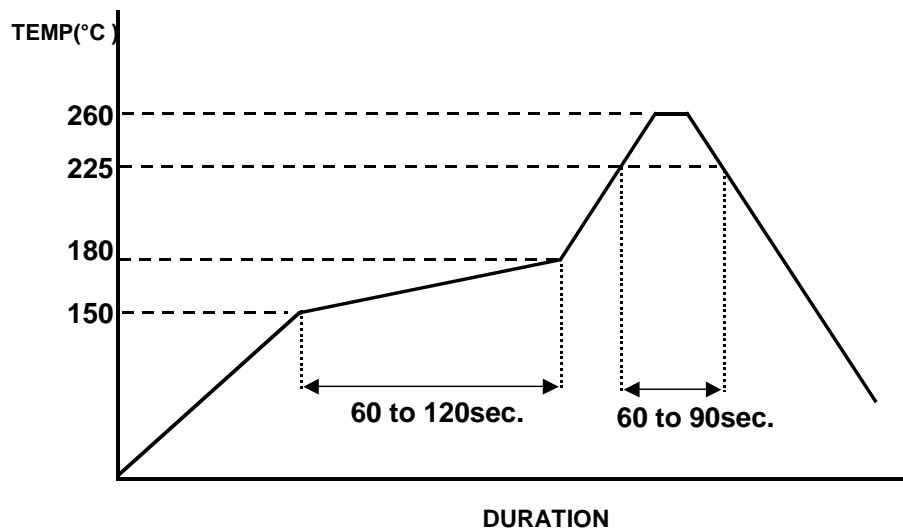

(Fig.1)

Reliability assurance item

(page: 1/1)

No.	Test Item	Test Methods	Specification Code
1	Vibration	5 to 26Hz: 1.52mm (total amplitude) 26 to 500Hz: 19.6m/s ² 20 minutes per 1 cycle. 2 hours for each 3 planes.	A
2	Shock	Half sine wave 6ms, 980 m/s ² . 3 times for each 3 planes.	A
3	Drop Test	Drop freely on the concrete from the height of 150cm With jig(150g). 3time for each 6 planes.	A
4	Humidity	+60°C, 95% RH for 48H. And normal temperature, with normal humidity for 24H.	A

Specification code	Specification
A	After the test, shall meet electrical specification.

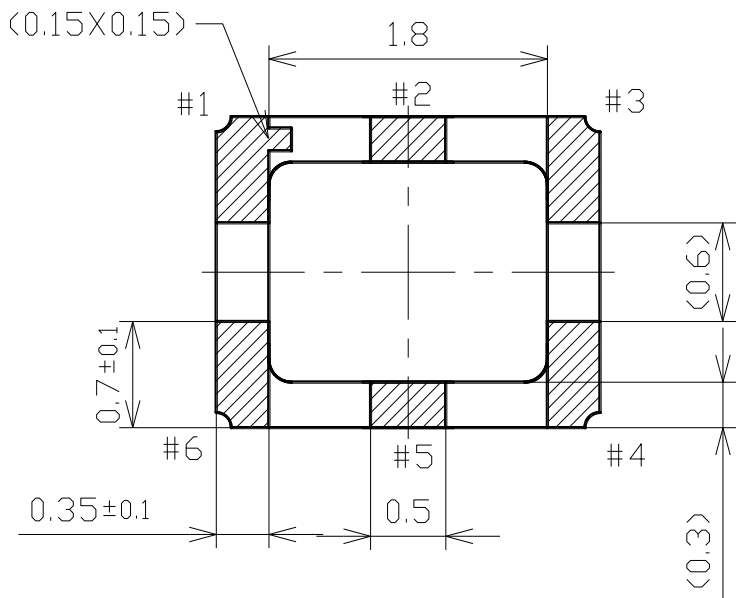
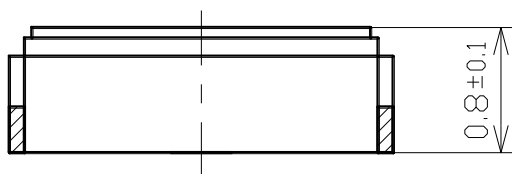
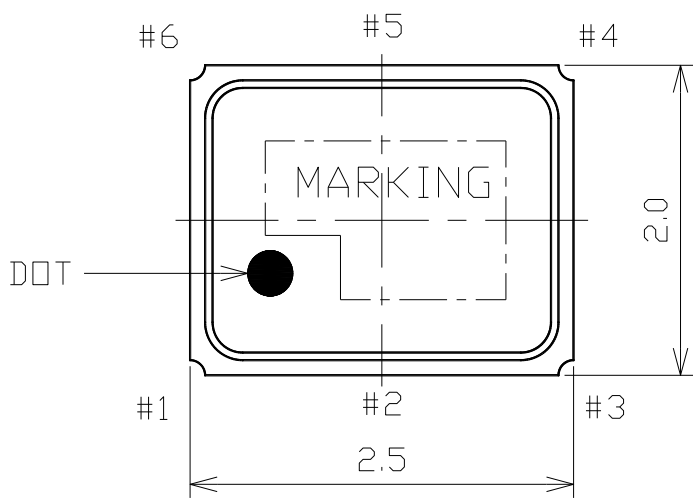

Connection diagram

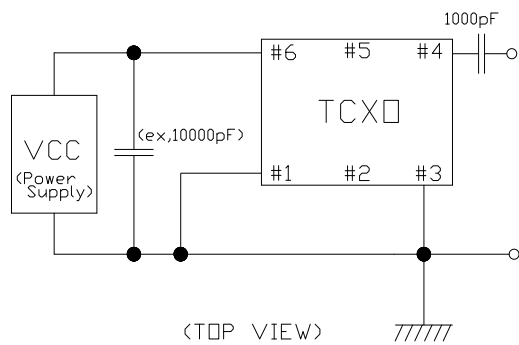

Terminal land connections	
#1	NC or GND (ground recommended)
#3	GND
#4	OUTPUT
#6	VCC
#2/#5	NC or GND

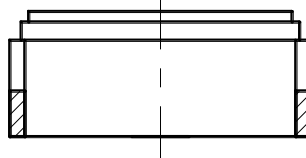

Date of Revise	Charge	Approved	Reason	
B 23.Aug.2013	R.Yoshizaki	K.Moriya	Change of Hatching and connection diagram (According to EEN01A-00005)	
Date	Name	Third Angle Projection	Tolerance	Scale
Drawn 23.Mar.2011	K.Hasegawa	Dimension:mm	+/- 0.2	20/1
Designed 23.Mar.2011	K.Hasegawa	Title	Drawing No.	Rev.
Checked 23.Mar.2011	Y.Akasaka			
Approved 23.Mar.2011	K.Moriya			
Dimension of External			ETD14B-01474	B

NIHON DEMPA KOGYO CO., LTD.

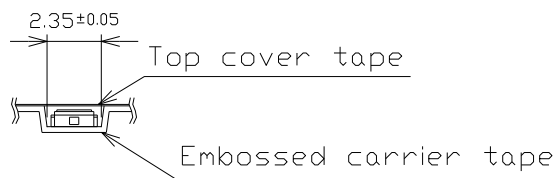
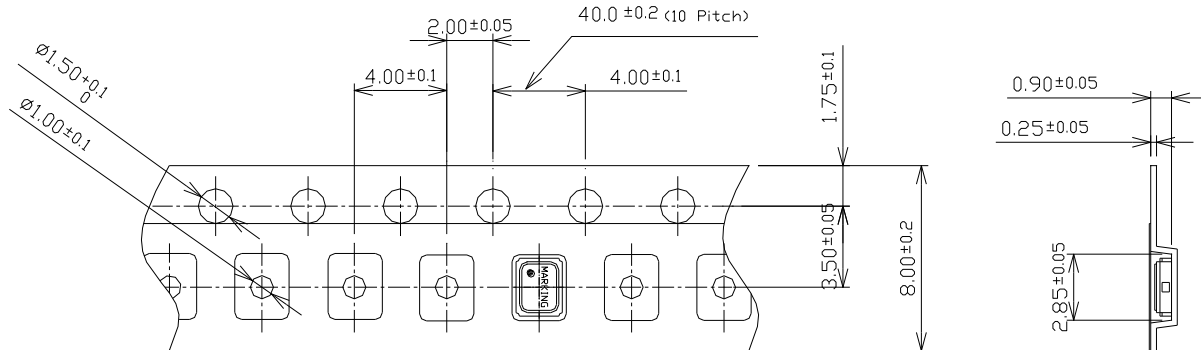

	Embossed carrier tape	Top cover tape
Materials	PS	PET + PE + Adhesive layer
Disposition	Antistatic	Antistatic

	Date of Revise	Charge	Approved	Reason	
A	18.Nov.2010	R.Yoshizaki	K.Moriya	Amount addition	
	Date	Name	Third Angle Projection	Tolerance	Scale
Drawn	19.May.2010	M.Kashiwamura	Dimension:mm	-----	-----
Designed	19.May.2010	M.Kashiwamura	Title	Drawing No.	Rev.
Checked	19.May.2010	K. Moriya			
Approved	19.May.2010	K. Moriya			
			Packing	ETK17B-00301 (1/3)	A

NIHON DEMPA KOGYO CO., LTD.

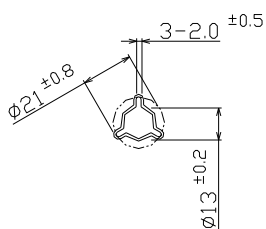
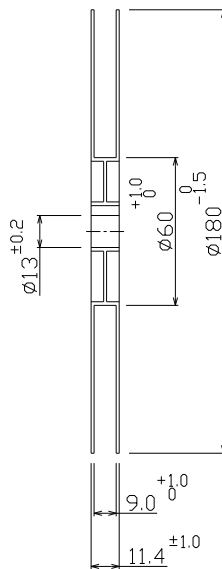
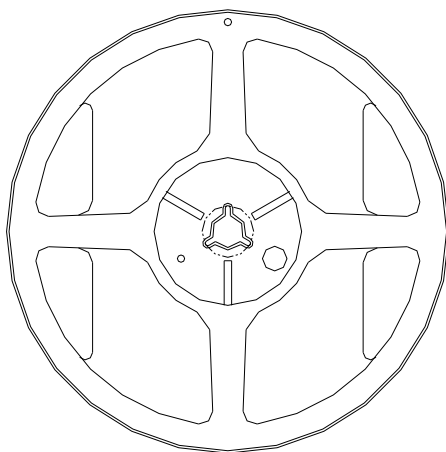

Materials : PS
Disposition : Antistatic

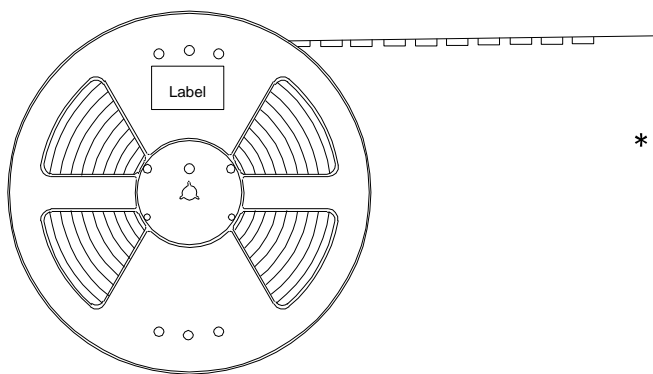
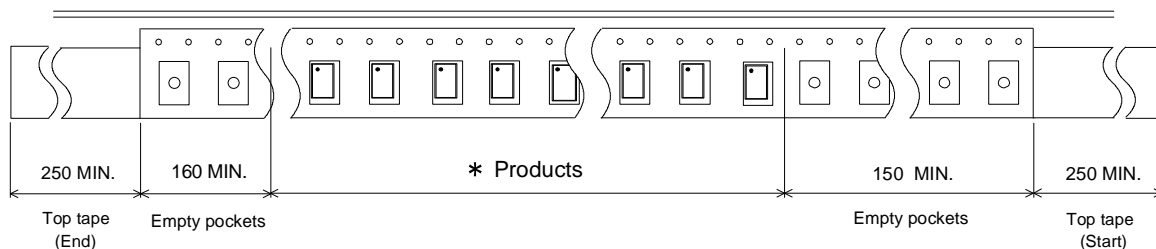

* There are no vacant pockets for this area.

	Date of Revise	Charge	Approved	Reason	
A					
	Date	Name	Third Angle Projection	Tolerance	Scale
Drawn	19.May.2010	M.Kashiwamura	Dimension:mm	-----	-----
Designed	19.May.2010	M.Kashiwamura	Title	Drawing No.	Rev.
Checked	19.May.2010	K. Moriya			A
Approved	19.May.2010	K. Moriya			
			Packing	ETK17B-00301 (2/3)	

NIHON DEMPA KOGYO CO., LTD.

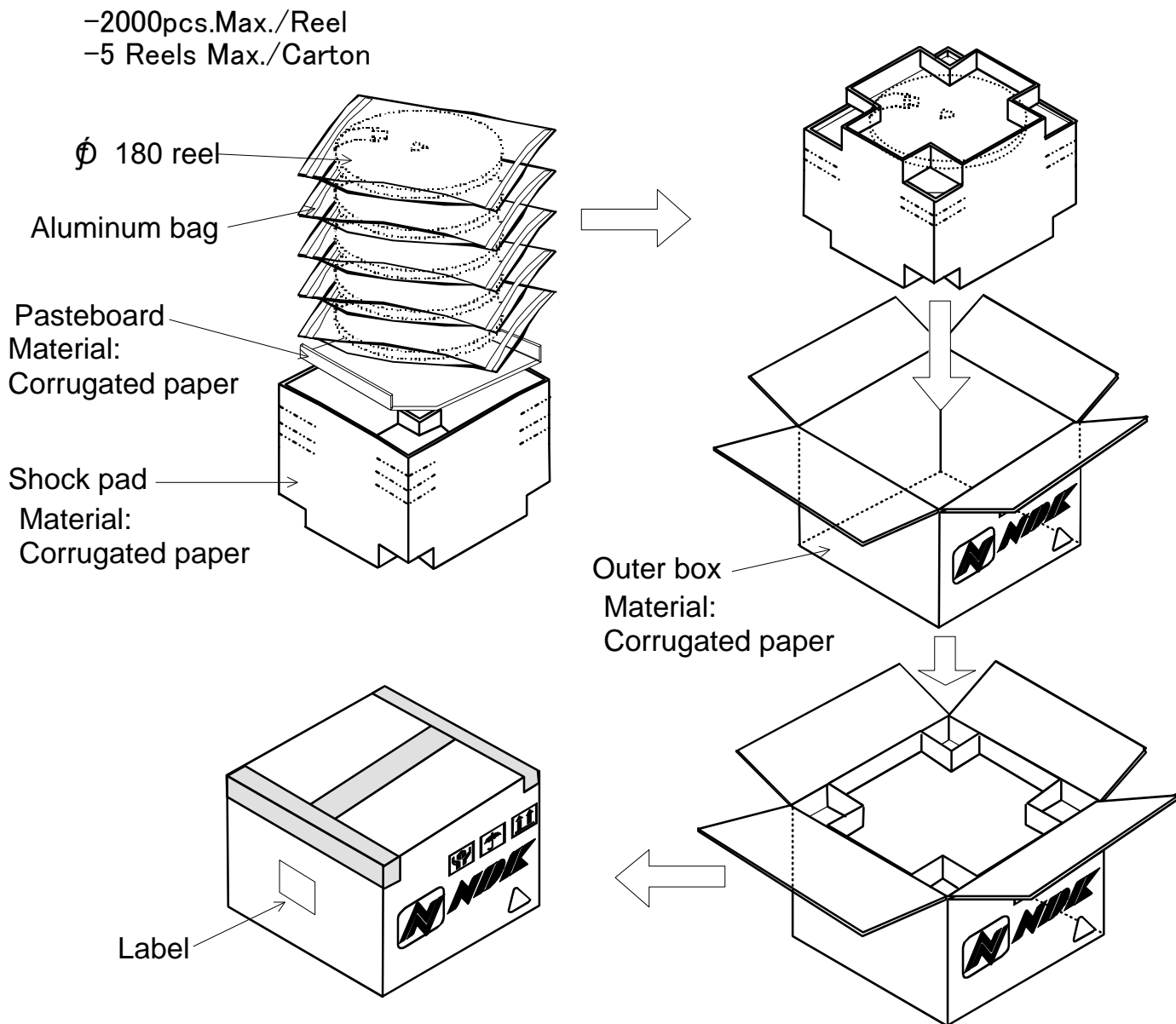

	Date of Revise	Charge	Approved	Reason	
A					
	Date	Name	Third Angle Projection	Tolerance	Scale
Drawn	19.May.2010	M.Kashiwamura	Dimension:mm	----	----
Designed	19.May.2010	M.Kashiwamura	Title	Drawing No.	Rev.
Checked	19.May.2010	K. Moriya			
Approved	19.May.2010	K. Moriya			
Packing			ETK17B-00301 (3/3)		A

NIHON DEMPA KOGYO CO., LTD.

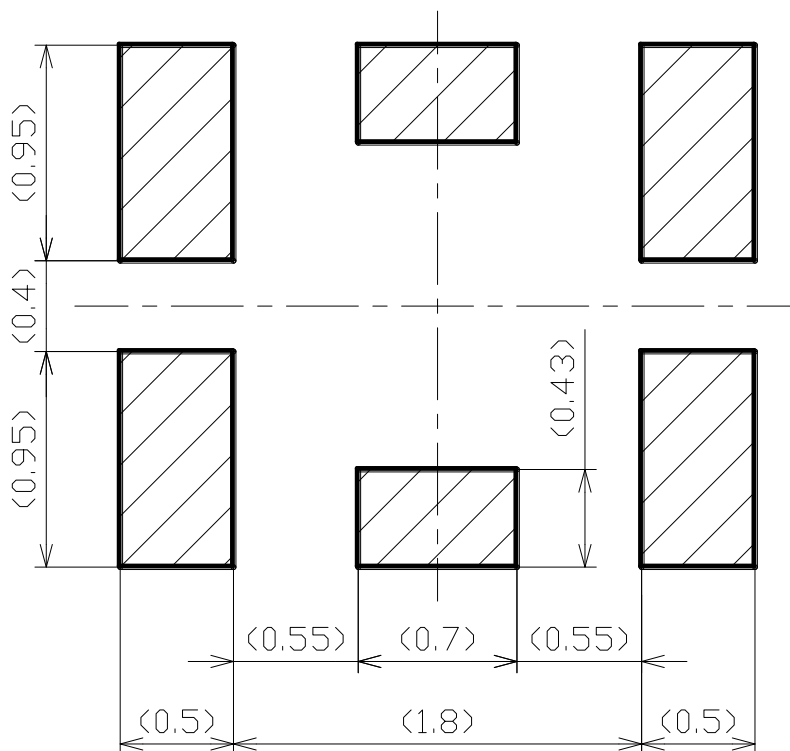

Note) Please reserve a large ground pattern on the PCB where the oscillator is installed.

	Date of Revise	Charge	Approved	Reason	
A	17. Nov. 2011	A.Fujii	K.Moriya	Note change	
	Date	Name	Third Angle Projection	Tolerance	Scale
Drawn	18.Apr.2007	H.Harima	Dimension:mm	----	30 / 1
Designed	18.Apr.2007	H.Harima	Title	Drawing No.	Rev.
Checked	18.Apr.2007	K.Moriya			
Approved	18.Apr.2007	H.Mizumura			
			Land pattern	ETD15B-00022	A

NIHON DEMPA KOGYO CO., LTD.