



# SPECIFICATION

Customer: \_\_\_\_\_

Item: CRYSTAL OSCILLATOR

Type: NT2016SA

Nominal frequency: 38.4 MHz

Customer's Spec. No.: -----

NDK Spec. No.: END4192A

Receipt
---------

Charge:

Sales	Sales Dept. 6 T.Takeuchi	Tel. + 81-3-5453-6783	<u>Approved</u>	<u>A.Konda</u>
Engineer	Engineering Dept. 3 S.Kawahara	Tel. +81-4-2900-6634	<u>Checked</u>	<u>T.Abe</u>
			<u>Drawn</u>	<u>S.Kawahara</u>

Revision Record				
Rev.	Rev. Date	Items	Contents	Remarks
----		Rev temp range		

1. Type  
NT2016SA
2. Maximum Ratings
  - 2.1 Supply Voltage  
-0.6 to +4.6V
  - 2.2 Storage temp. range  
-40 to +85°C
3. Rating
  - 3.1 Nominal Frequency  
38.4MHz (3 digits marking without the decimal point: 384)
  - 3.2 Supply voltage  
+2.8V±5% DC (-Earth)
  - 3.3 Current consumption  
Max. 2.0mA
  - 3.4 Output voltage  
Min. 0.8Vp-p Clipped sine wave (DC-Coupling)
  - 3.5 Operating temp. range  
-40 to +85°C
  - 3.6 Load impedance  
(10kΩ//10pF)±10%
  - 3.7 DC-cut capacitor  
DC-cut capacitor of output is not put in VC-TCXO.  
Please add DC-cut capacitor (1000pF) in output line.
  - 3.8 Mass  
Max. 0.02g
4. Electrical specification
  - 4.1 Frequency stability
    - 4.1.1 Frequency / temperature characteristics  
Max. ±2.5ppm/ -40 to +85°C  
(Based on frequency at +25°C)
    - 4.1.2 Frequency/Voltage coefficient  
Max. ±0.2ppm/+2.8V±5%,
    - 4.1.3 Frequency/Load coefficient  
Max. ±0.2ppm/(10kΩ//10pF)±10%
    - 4.1.3 Frequency tolerance  
Max. ±1.5ppm (at +25±2°C, after 2times reflow soldering, based on nominal frequency)
    - 4.1.4 Long term frequency stability  
Max. ±1.0ppm/ year
  - 4.2 Symmetry  
40 to 60%
  - 4.3 Harmonic distortion  
Max. -5dBc
  - 4.4 Start-up time  
Max. 2.0ms (@90% of final Vout level)
  - 4.5 Phase noise  
Max. -125dBc/Hz (@1kHz offset)  
Max. -140dBc/Hz (@10kHz offset)  
Max. -145dBc/Hz (@100kHz offset)  
Max. -145dBc/Hz (@1MHz offset)
5. Reflow soldering  
Conditions of temperature profile (Refer to Fig.1)  
Soldering peak temp. +260°C

## 6. Marking

- (1) Lot No.
- (2) KV (Type identification number)
- (3) Manufacture Name (NDK symbol mark)
- (4) Output frequency (MHz)
- (5) Trace code

## 7. Inspection parameters

Para 3.1, 3.3, 3.4, 4.1.1, 6, 11.2 are inspected.

The other parameters are guaranteed to be within specified characteristics by NDK design.

Inspection data is not submitted for mass production lot.

But only if requested, a copy of first lot production data will be submitted.

## 8. Precaution in the storage

[Please keep the oscillator in the ordinary temperature and humidity that are suggested as below table.]

	Before taking out of dry bag	After taking out of dry bag
Temperature	+5°C to +45°C	+30°C max.
Humidity	10% to 75% RH	70% max.
Period	6 months	168 hours *

(table)

[\* It is desirable for the oscillator to be used within 168 hours after taking out of dry bag.

Please pack the oscillator into used dry bag with a desiccant and seal it up by heat sealer etc.

In case the heat sealer is not available, sealing up with cellophane tape or a vinyl tape will do.]

## 9. Frequency establishment condition

When output frequency is set, we suppose to have the ground pattern under the oscillator.

## 10. Washing

Not available for washing.

## 11. Application drawing

## 11.1 Reliability assurance item

ETS30B-00399

## 11.2 Dimension of External

ETD14B-01324

## 11.3 Marking

ETH11B-00316A

## 11.4 Packing

ETK17B-00302A

## 11.5 Land pattern

ETD15B-00020A

## 12. Notice

12.1 Order items are manufactured according to specification. As to conditions, which are not indicated in this specification and unpredictable such as applied condition and oscillation margin, please check them beforehand.

12.2 Unless we receive request for modification within 3 weeks from the issue date of this NDK specification sheet, we will supply products according to this specification. Also, if you'd like to modify specification of order, which has been placed with delivery request within 3 weeks from the issue data of this specification sheet, we would like to discuss with you separately.

12.3 In no event shall the company be liable for any product failure resulting from an inappropriate handling or operation of the product beyond the scope of its guarantee.

12.4 Where any change to the process condition is made due to the change(s) in the production line, inform personnel of the specifications.

- 12.5 Should this specification data give rise to any disputes relating to any intellectual property rights or any other rights of a third person, the company shall not indemnify anyone for any damage.  
Their disclosure must not be construed as the grant of a license to use any of the intellectual property rights owned by the company.
- 12.6 If you intend to use products listed on this specification for applications that may result in loss of life or assets (controls relating to safety, medical equipment, aeronautical equipment, space equipment, etc.), please do not fail to advise us of your intention beforehand.
- 12.7 In the company's production process whatever amount of ozone depleting substances (ODS) as specified in the Montreal protocol is not used.
- 12.8 Information contained in this specification must not be quoted, reproduced or used for other purposes including processing either in part or in full without obtaining prior approval from the company.
- 12.9 If you use resin for fixing components during manufacturing, please keep resin from adhering to the oscillator.

13. Prohibited items

Be sure to use the product under the following conditions. Otherwise, the characteristics deterioration or destruction of the product may result.

- (1) Reflow soldering heat resistance  
Peak temperature: +265 °C  
Heating: +225 °C or higher, 90 sec
- (2) Manual soldering heat resistance  
Pressing a soldering iron of +410 °C on the terminal electrode for five seconds.

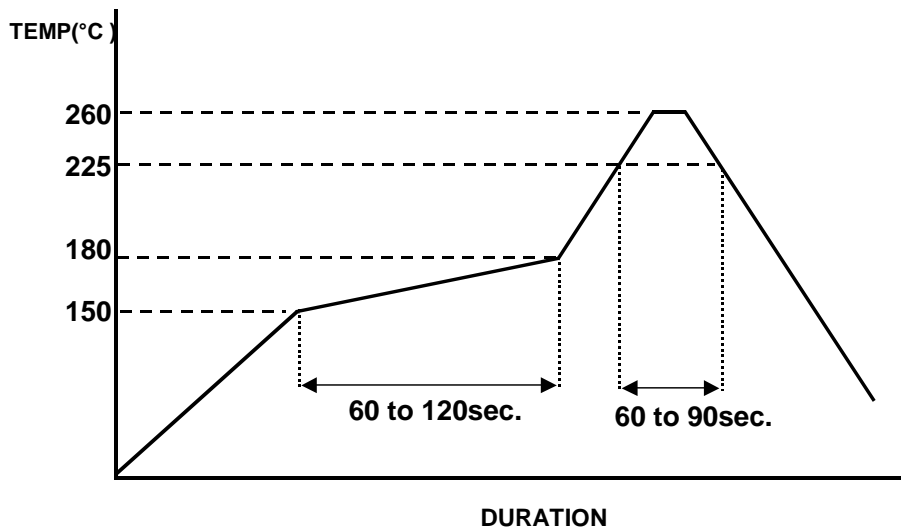

( Fig.1 )

**Reliability assurance item**

(page: 1/1)

No.	Test Item	Test Methods	Specification Code
1	Vibration	5 to 26Hz: 1.52mm (total amplitude) 26 to 500Hz: 19.6m/s <sup>2</sup> 20 minutes per 1 cycle. 2 hours for each 3 planes.	A
2	Shock	Half sine wave 6ms, 980 m/s <sup>2</sup> . 3 times for each 3 planes.	A
3	Drop Test	Drop freely on the concrete from the height of 150cm With jig(150g). 3time for each 6 planes.	A
4	Humidity	+60°C, 95% RH for 48H. And normal temperature, with normal humidity for 24H.	A

Specification code	Specification
A	After the test, shall meet electrical specification.

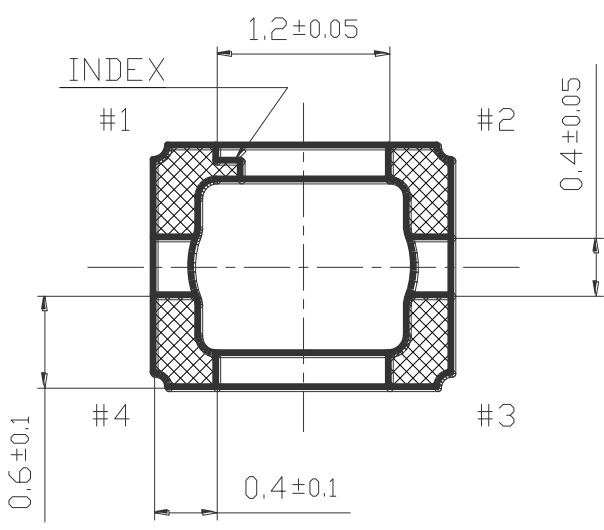
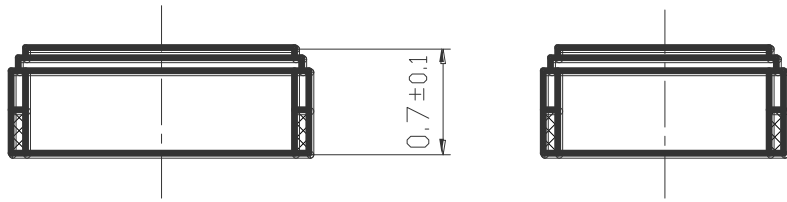
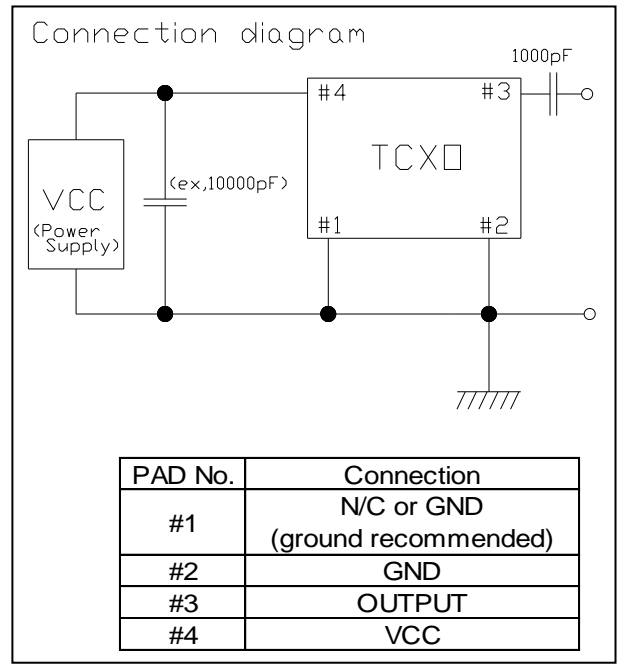
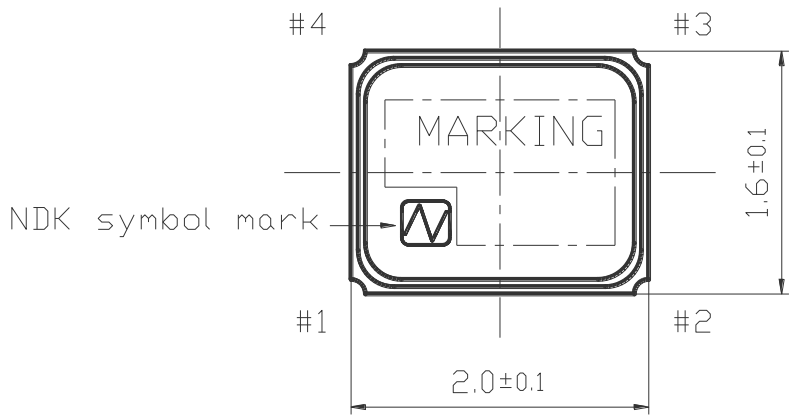

Date of Revise		Charge	Approved	Reason	
Drawn	8.Oct.2009	M.Kashiwamura	Third Angle Projection Dimension:mm	Tolerance +/- 0.2	Scale 20 / 1
Designed	8.Oct.2009	Y.Kanehira	Title <b>Dimension of External</b>	Drawing No. <b>ETD14B-01324</b>	Rev.
Checked	8.Oct.2009	K.Moriya			
Approved	8.Oct.2009	K.Moriya			

**NIHON DEMPA KOGYO CO., LTD.**

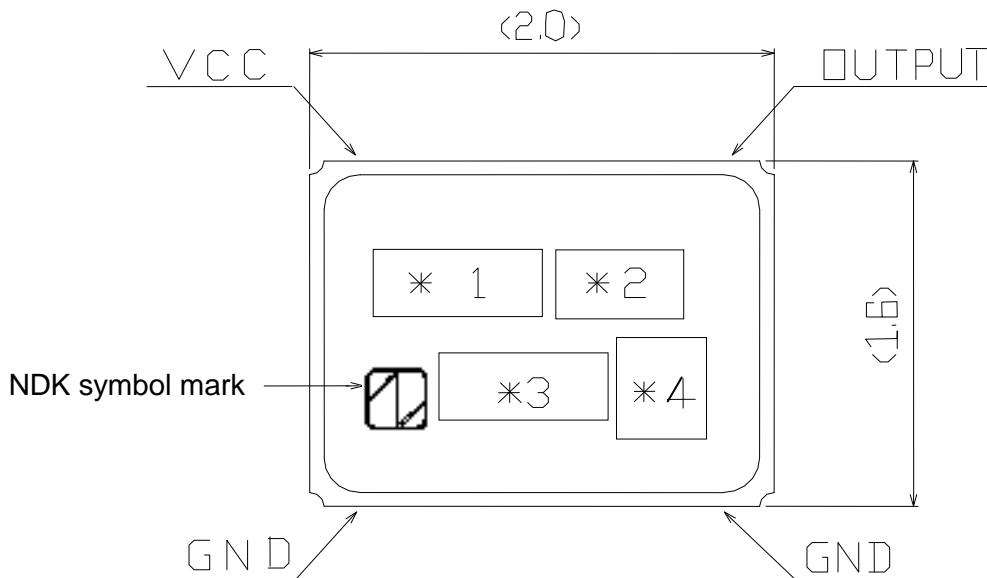

(Marking Contents)

\*1 Lot No.



Year Code (Last one digit)

Month Code (see table)

Month	1	2	3	4	5	6	7	8	9	10	11	12
Month Code	1	2	3	4	5	6	7	8	9	O	N	D

Following No.

Production Factory

<Example>

31E Sayama Factory

31E\* Hakodate NDK

\*2 Type identification number

\*3 Output Frequency

- A unit (MHz) is not written.
- A decimal point omits.

\*4 Trace code

Trace code is consisted of four digit numbers of numeral or letters.  
This code indicates production date and production line number.

	Date of Revise	Charge	Approved	Reason		
A	14. May. 2009	A.Teranishi	H. Mizumura	*1: Change of example		
	Date	Name	Third Angle Projection	Tolerance	Scale	
Drawn	8.Apr.2008	A.Teranishi	Dimension:mm	---	---	
Designed	8.Apr.2008	K.Moriya	Title	Drawing No.	Rev.	
Checked	8.Apr.2008	K.Moriya			A	
Approved	8.Apr.2008	H. Mizumura			ETH11B-00316	
			<b>Marking</b>			

**NIHON DEMPA KOGYO CO., LTD.**

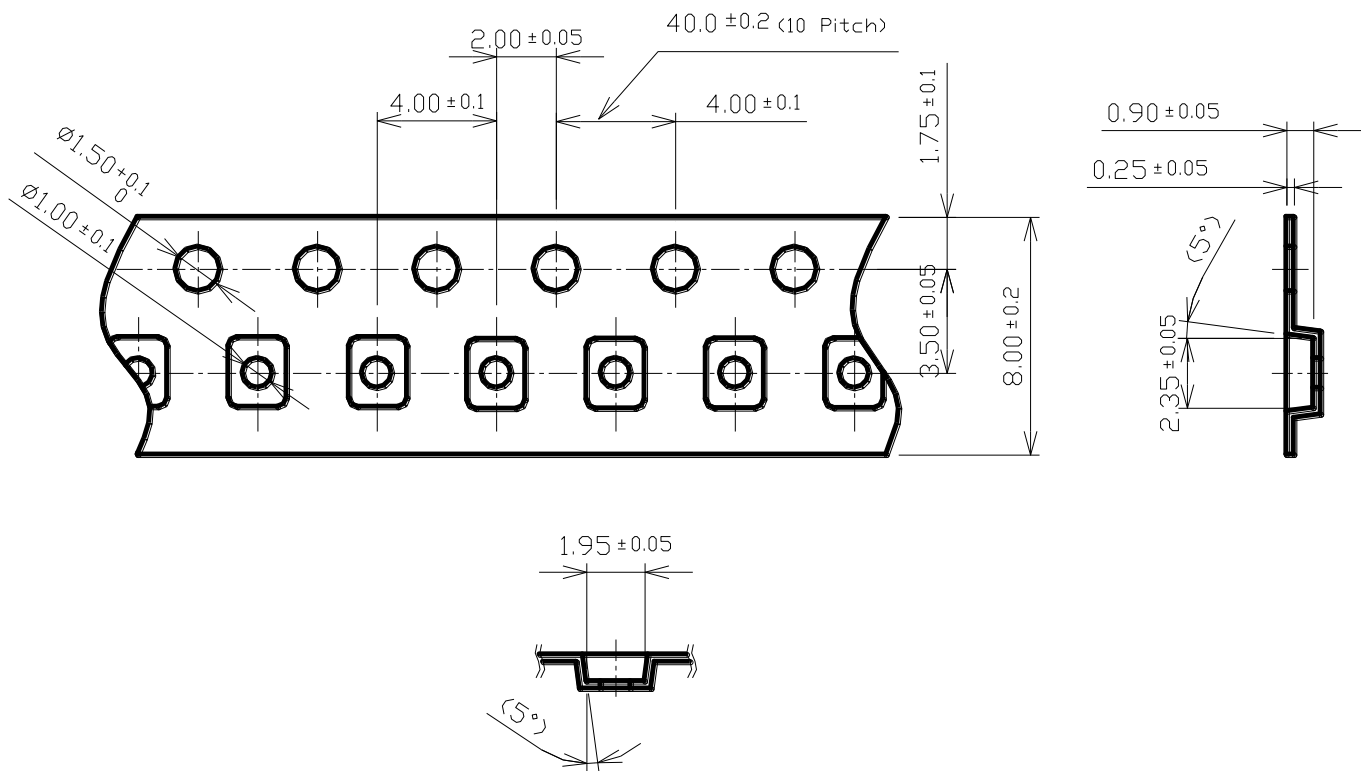

	Embossed carrier tape	Top cover tape
Materials	PS	PET + PE + Adhesive layer
Disposition	Antistatic	Antistatic

	Date of Revise	Charge	Approved	Reason	
A					
	Date	Name	Third Angle Projection	Tolerance	Scale
Drawn	19.May.2010	M.Kashiwamura	Dimension:mm	-----	-----
Designed	19.May.2010	M.Kashiwamura	Title	Drawing No.	Rev.
Checked	19.May.2010	K. Moriya			
Approved	19.May.2010	K. Moriya			
<b>Packing</b>			<b>ETK17B-00302 (1/3)</b>		<b>A</b>

**NIHON DEMPA KOGYO CO., LTD.**

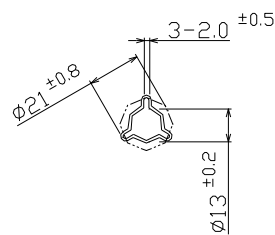
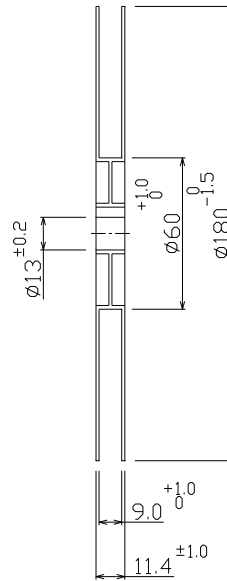
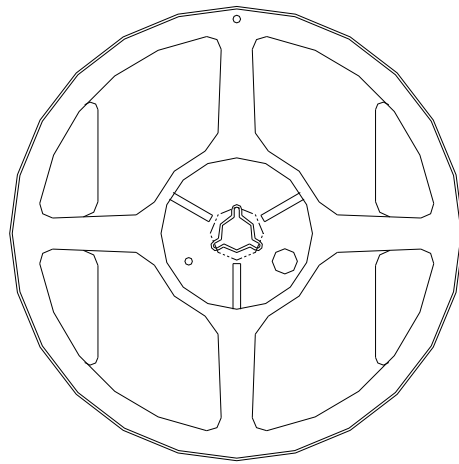

Materials : PS  
Disposition : Antistatic

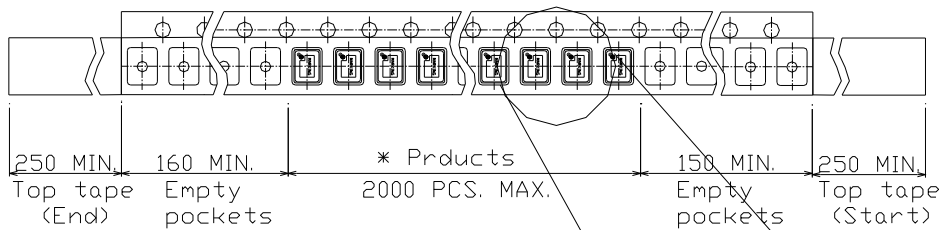

\* There are no vacant pockets for this area.

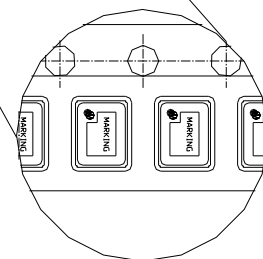
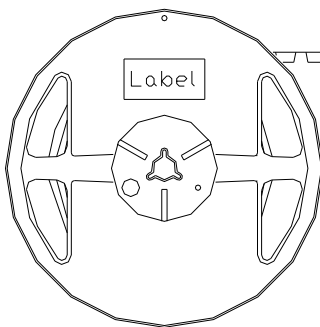

Date of Revise		Charge	Approved	Reason	
A					
	Date	Name	Third Angle Projection	Tolerance	Scale
Drawn	19.May.2010	M.Kashiwamura	Dimension:mm	-----	-----
Designed	19.May.2010	M.Kashiwamura	Title	Drawing No.	Rev.
Checked	19.May.2010	K. Moriya			
Approved	19.May.2010	K. Moriya			
			<b>Packing</b>	<b>ETK17B-00302 (2/3)</b>	<b>A</b>

**NIHON DEMPA KOGYO CO., LTD.**

-2000pcs.Max./Reel  
 -5 Reels Max./Carton

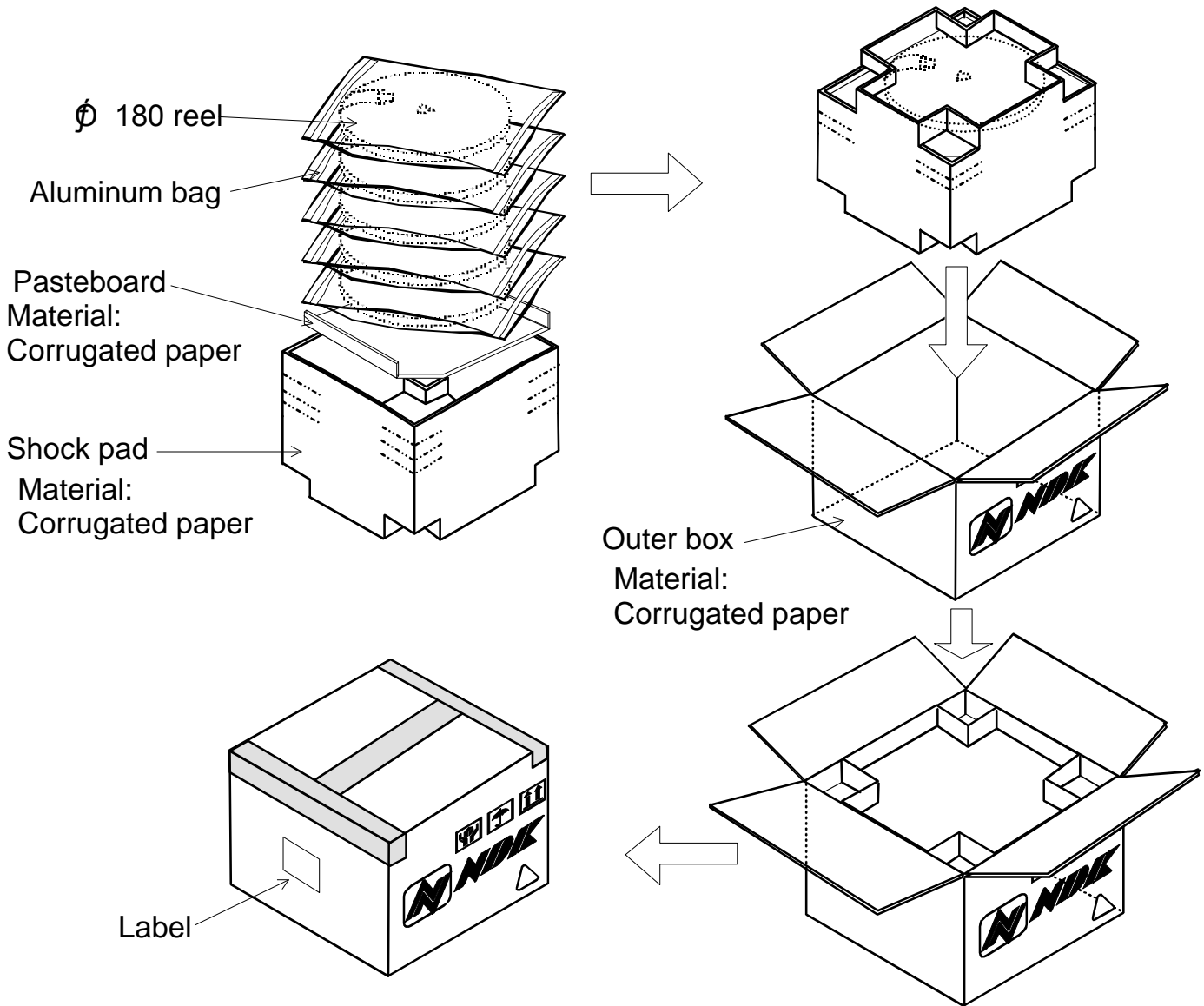

	Date of Revise	Charge	Approved	Reason	
A	18.Nov.2010	R.Yoshizaki	K.Moriya	Amount addition	
	Date	Name	Third Angle Projection	Tolerance	Scale
Drawn	19.May.2010	M.Kashiwamura	Dimension:mm	-----	3/1
Designed	19.May.2010	M.Kashiwamura	Title	Drawing No.	Rev.
Checked	19.May.2010	K. Moriya			
Approved	19.May.2010	K. Moriya			
<b>Packing</b>			<b>ETK17B-00302 (3/3)</b>		<b>A</b>

**NIHON DEMPA KOGYO CO., LTD.**

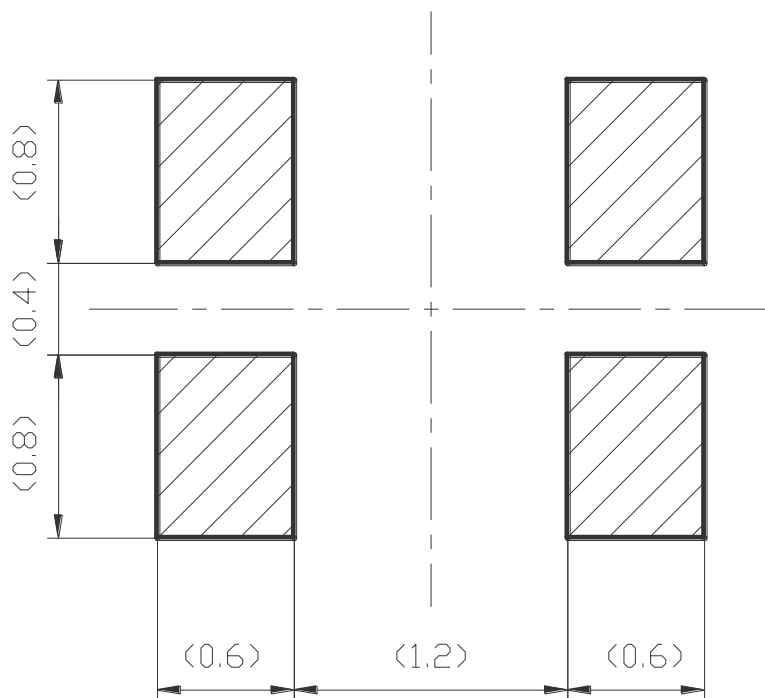

Note) Please reserve a large ground pattern on the PCB where the oscillator is installed.

	Date of Revise	Charge	Approved	Reason	
A	8.Jul.2011	Y.Kanehira	A.Konda	Change Note	
	Date	Name	Third Angle Projection	Tolerance	Scale
Drawn	19.Mar.2007	H.Harima	Dimension:mm	-----	30 / 1
Designed	19.Mar.2007	H.Harima	Title	Drawing No.	Rev.
Checked	19.Mar.2007	K.Moriya			
Approved	19.Mar.2007	H.Mizumura			
			<b>Land pattern</b>	<b>ETD15B-00020</b>	<b>A</b>

**NIHON DEMPA KOGYO CO., LTD.**