

Product Overview

NSE11409-Q1 is a 90mΩ low-side switch with 48V clamp voltage for automotive applications. It's designed for driving resistive or inductive loads with one side connected to the battery. Internal 48V clamp circuit protects device from surge energy when fast demagnetization at turn-off.

With internal output current limitation, the device is protected in overload condition. Built-in thermal shutdown protects the chip from over-temperature and short-circuit. A thermal swing mechanism is built to limit dissipated power to decelerate power accumulation. Thermal shutdown, with automatic restart, allows the devices to recover normal operation as soon as a fault condition disappears.

An internal diagnostic function is built to indicate any faults when thermal shutdown and open-drain conditions through an open-drain status output pin. This device operates in ambient temperatures from -40°C to 125°C.

Key Features

- AEC-Q100 qualified
- Drain current limitation: 8.5A
- 48V overvoltage clamp
- Thermal shutdown protection
- Thermal swing protection
- Fault diagnostic block
 - Thermal shutdown diagnosis
 - Open-drain diagnosis
- Very low standby current
- Very low electromagnetic susceptibility
- ESD protection
- RoHS-compliant package

Applications

- Automotive Relays
- Solenoids
- Valves
- Lighting

Device Information

Part Number	Package	Body Size
NSE11409-QSPR	SO-8	4.9mm x 3.9mm
NSE11409-QSTBR	SOT223	6.48mm x 3.38mm

Typical Application

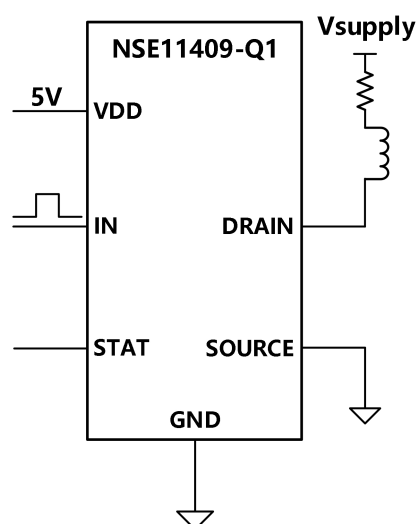

Index

1. PIN CONFIGURATION AND FUNCTIONS.....	3
2. BLOCK DIAGRAM.....	3
3. ABSOLUTE MAXIMUM RATINGS.....	4
4. THERMAL INFORMATION.....	5
5. SPECIFICATIONS.....	5
5.1. ELECTRICAL CHARACTERISTICS.....	5
5.2. TYPICAL PERFORMANCE CHARACTERISTICS.....	7
5.2.1. <i>True table</i>	7
5.2.2. <i>Electrical characteristics curves</i>	7
6. PROTECTIONS.....	8
6.1. CURRENT LIMITATION.....	8
6.2. THERMAL SHUTDOWN AND THERMAL SWING.....	8
7. APPLICATION INFORMATION.....	8
7.1. MCU I/O PROTECTION.....	9
7.2. THE VALUE OF STATUS PULL UP RESISTOR.....	10
8. PACKAGE INFORMATION.....	11
8.1. SO-8.....	11
8.2. SOT223.....	11
9. REVISION HISTORY.....	12

1. Pin Configuration and Functions

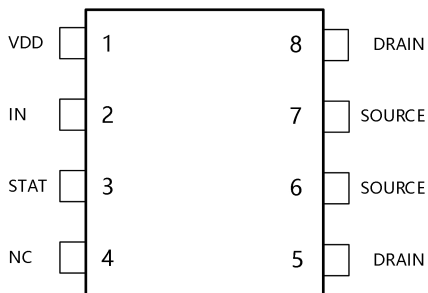

Table 1 SO-8 Pin Configuration and Description

PIN NO.	SYMBOL	FUNCTION
1	VDD	Power supply pin.
2	IN	CMOS compatible, voltage controlled input pin.
3	STAT	Open drain digital diagnostic pin.
4	NC	Not connect.
5, 8	DRAIN	PowerMOS drain.
6, 7	SOURCE	PowerMOS source.

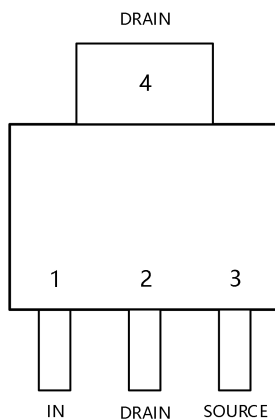
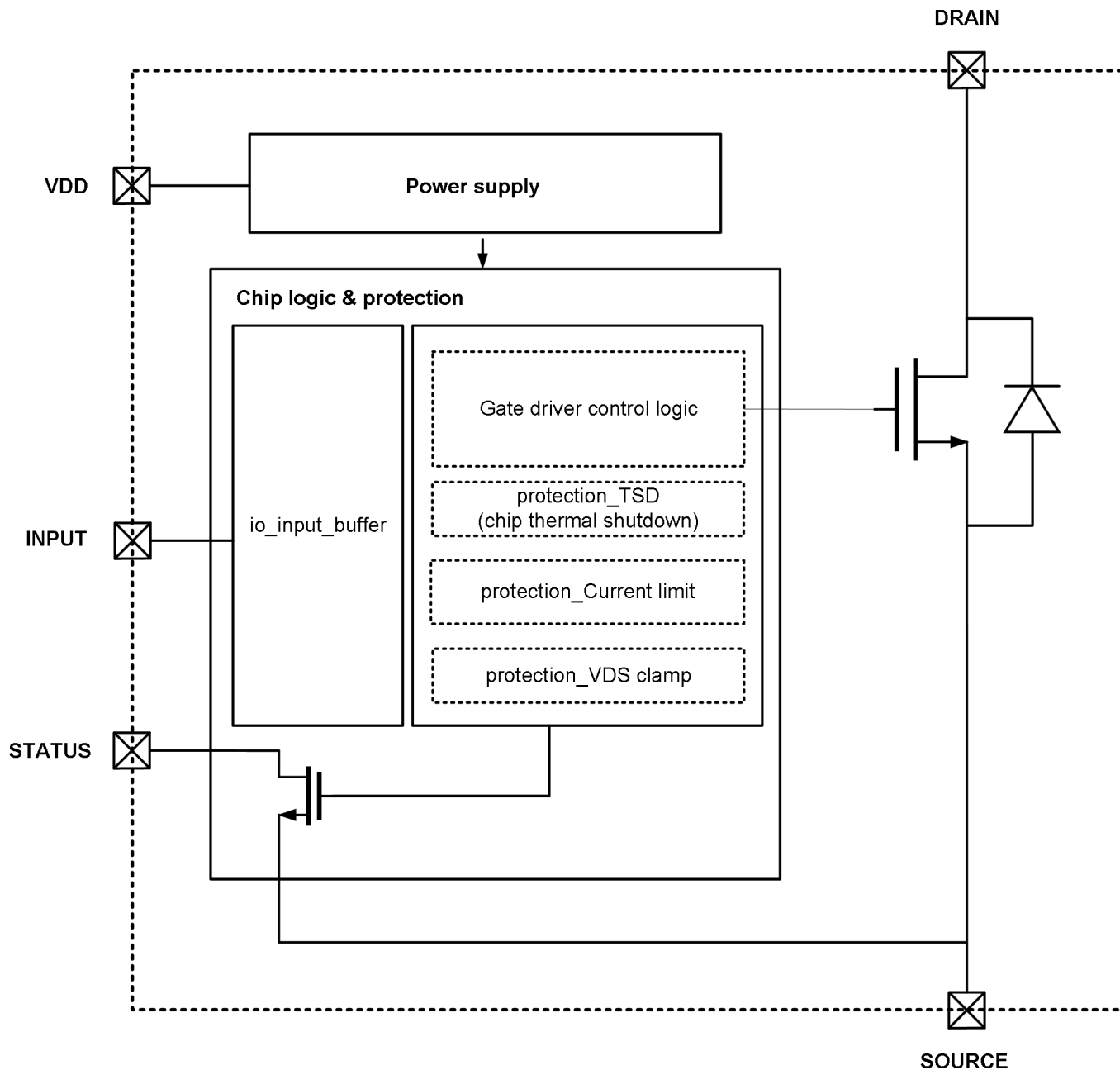

Table 2 SOT223 Pin Configuration and Description

PIN NO.	SYMBOL	FUNCTION
1	IN	CMOS compatible, voltage controlled input pin.
2, 4	DRAIN	PowerMOS drain.
3	SOURCE	PowerMOS source.

2. Block diagram



3. Absolute Maximum Ratings

Parameters	Symbol	Min	Typ	Max	Unit
Drain-to-Source Voltage	V_{DS}			Internally clamped	V
DC Drain Current	I_D			Thermal limited	A
Reverse DC drain current	$-I_D$			12.5	A

Parameters	Symbol	Min	Typ	Max	Unit
VDD Pin Current	I_{VDD}	-1		10	mA
INPUT Pin Current	I_{IN}	-1		10	mA
STATUS Pin Current	I_{STAT}	-1		10	mA
Junction Temperature	T_J	-40		150	°C
Storage Temperature	T_{stg}	-55		150	°C
Electrostatic discharge, Human-body model	HBM	-3000		3000	V
Electrostatic discharge, Charged-device model	CDM	-2000		2000	V

4. Thermal Information

Parameters	Symbol	SO-8	SOT223	Unit
IC Junction-to-ambient Thermal Resistance	θ_{JA}	94.5 ⁽¹⁾	73 ⁽¹⁾	°C/W

Notes:

1). Four layers 2s2p PCB JEDEC JESD 51-7

5. Specifications

5.1. Electrical Characteristics

(VDD = VIN= 4.5 V to 5.5 V, Tj=-40°C to 150°C. Unless otherwise noted.)

Parameters	Symbol	Min	Typ	Max	Unit	Comments
Power MOSFET						
ON-state resistance	R_{ON}		90	180	mΩ	ID = 1.6 A; VDD = VIN = 5 V
Drain-source clamp voltage	V_{CLAMP}	46	48	56	V	VIN = 0V; ID = 1.6 A
Drain-source clamp threshold voltage	V_{CLTH}	40			V	VIN = 0V; ID = 2 mA
OFF-state output current	I_{DSS}	0		3	μA	VIN = 0 V; VDS = 13 V; Tj = 25°C
		0		5	μA	VIN = 0 V; VDS = 13 V; Tj = 125°C
Bode diode forward voltage	V_{BD}		0.8		V	ID = 1.6 A; VIN = 0 V
VDD						
Operating supply voltage	V_S	3.5	5	5.5	V	
Operating supply current	I_S		10	25	μA	OFF-state; Tj = 25°C; VIN = VDS = 0 V;
			25	65		ON-state; VIN = 5 V; VDS = 0 V

Parameters	Symbol	Min	Typ	Max	Unit	Comments
Supply clamp voltage	V _{SCL}	5.5		8	V	ISCL = 1 mA
			-0.7			ISCL = -1 mA
Logic Input						
Low-level input voltage	V _{IL}			0.9	V	
Low-level input current	I _{IL}	1			μA	VIN = 0.9 V
High-level input voltage	V _{IH}	2.1			V	
High-level input current	I _{IH}			10	μA	VIN = 2.1 V
Input hysteresis voltage	V _{I(hyst)}	0.13			V	
Input clamp voltage	V _{ICL}	5.5		8		IIN = 1 mA
			-0.7			IIN = -1 mA
Status indicator						
Status low output voltage	V _{STAT}			0.5	V	I _{STAT} = 1 mA
Status leakage current	I _{LSTAT}			10	μA	V _{STAT} = 5 V
Status pin input capacitance	C _{STAT}			100	pF	V _{STAT} = 5 V
Status clamp voltage	V _{STCT}	5.5		8	V	I _{STAT} = 1 mA
			-0.7			I _{STAT} = -1 mA
Open load detection						
Open load OFF-state voltage detection threshold	V _{OI}	1.1	1.2	1.3	V	VIN = 0 V
Delay between INPUT falling edge and STATUS falling edge in open load condition	t _{d(STAT)}		225		μs	I _{OUT} = 0 A
Switching characteristics (Vsupply = VIN = 3.5V to 5.5 V, See Figure 6 for Switching timing characteristics)						
Turn-on delay time	t _{d(ON)}		8		μs	RL = 8.2 Ω; VCC = 13 V
Turn-off delay time	t _{d(OFF)}		18		μs	RL = 8.2 Ω; VCC = 13 V
Rise time	t _r		10		μs	RL = 8.2 Ω; VCC = 13 V
Fall time	t _f		10		μs	RL = 8.2 Ω; VCC = 13 V
Switching energy losses at turn-on	W _{ON}		57		μJ	RL = 8.2 Ω; VCC = 13 V
Switching energy losses at turn-off	W _{OFF}		55		μJ	RL = 8.2 Ω; VCC = 13 V
Protection and diagnostics						
DC short-circuit current	I _{limH}	5.5	8.5	11.5	A	VDS = 13 V; VS = VIN = 5V

Parameters	Symbol	Min	Typ	Max	Unit	Comments
Shutdown temperature	TTSD	150	175	200	°C	
Reset temperature	TR	$T_{RS} + 1$	$T_{RS} + 5$		°C	
Thermal reset of STATUS	TRS	135			°C	
Thermal hysteresis (TTSD - TR)	THYST		7		°C	
Dynamic temperature	ΔT_j		40		K	$T_j = -40^\circ\text{C}; V_{CC} = 13\text{V}$
Dynamic temperature hysteresis	$\Delta T_j(\text{HYS})$		15		K	

5.2. Typical Performance Characteristics

5.2.1. True table

Conditions	Input	Drain	Status
Normal operation	L	H	H
	H	L	H
Current limitation	L	H	H
	H	X	H
Over-temperature limitation	L	H	H
	H	H	L
VDD under-voltage	L	H	X
	H	H	X
Open-drain detection	L	L	L
	H	L	H

5.2.2. Electrical characteristics curves

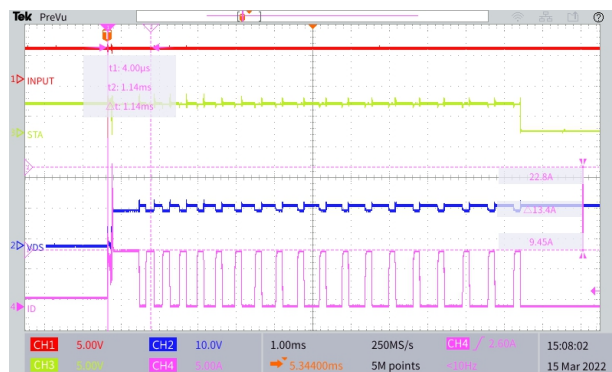
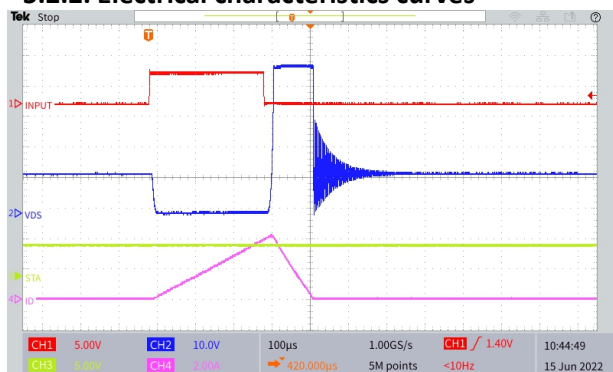

Figure 5-1 Inductive clamp voltage

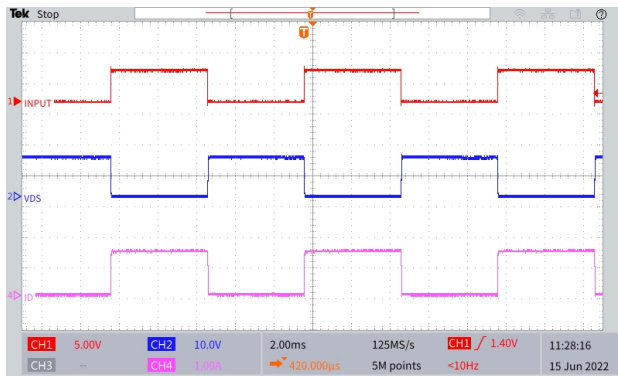

Figure 5-3 Normal load(1.5A, Rload, 25°C)

Figure 5-2 Thermal swing & current limitation

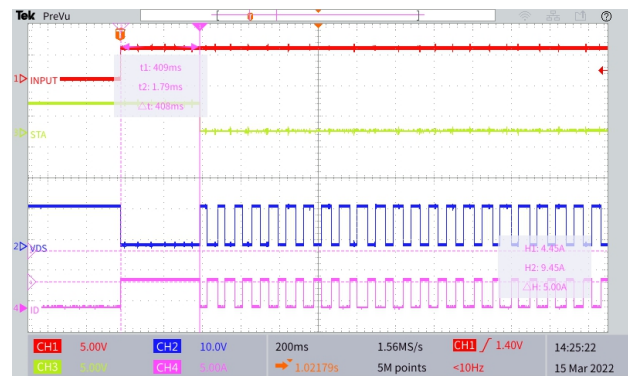

Figure 5-3 Thermal shutdown(5A, Rload, 85°C)

6. Protections

6.1. Current limitation

NSE11409-Q1 has current limitation to protect the silicon and bonding wire in case of overload or short circuit to ground.

6.2. Thermal shutdown and thermal swing

This device has both absolute and dynamic temperature protection. There are two thermal sensors on the controller and the MOSFET, the one on the MOSFET is the hottest and the one on the controller is the coldest. The absolute temperature protection is to shutdown the MOSFET when the hottest junction temperature exceeds the T_{TSD} , and the dynamic temperature protection is also to shutdown the MOSFET when the temperature difference between the hottest and the coldest exceeds ΔT_j .

7. Application Information

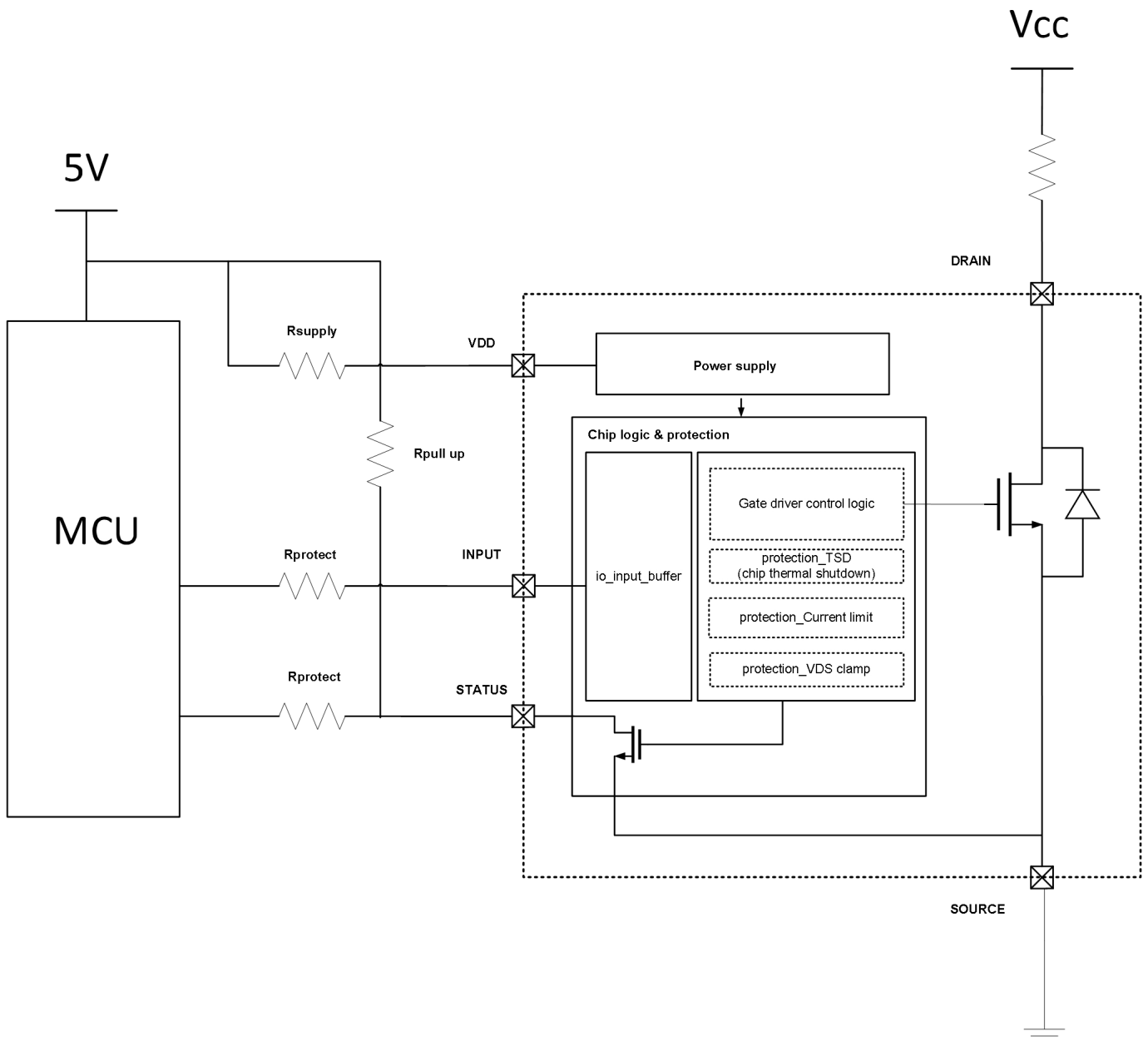

7.1. MCU I/O protection

NSE11409-Q1 has Zener diodes inside for ESD protection and the intrinsic NPN parasitic bipolar, so that resistors for protection are necessary in series with the digital inputs to limit the current to protect MCU I/Os during transient and reverse battery conditions.

The value of resistors for protection can be calculated by the formula as shown below:

$$\frac{V_{ICL}}{I_{latchup}} \leq R_{prot} \leq \frac{V_{MCU_OUT} - V_{IH}}{I_{IH\ max}}$$

Where V_{ICL} is reverse clamp voltage of NSE11409-Q1, $I_{latchup}$ is the MCU I/O latch up current, V_{MCU_OUT} is the output voltage of MCU I/O, V_{IH} is the High-level input voltage of NSE11409-Q1, I_{IH} is the high level input current.

Let:

$I_{\text{latchup}} \geq 20\text{mA}$; $V_{\text{MCU_OUT}} \geq 4.5\text{V}$, so $35\Omega \leq R_{\text{prot}} \leq 100\text{k}\Omega$. The recommended value is $1\text{k}\Omega$. The supply resistor is the same.

7.2. The value of STATUS pull-up resistor

Because the STATUS pin is open drain output, a pull up resistor is needed to fix the high voltage during normal operation. When the fault occurs, the voltage level of STATUS is pulled down by the internal MOSFET on. The value of pull-up resistor can be calculated by the formula as shown below:

$$\left(\frac{V_{\text{pull-up}}}{V_{\text{OL}}} - 1\right) \cdot R_{\text{on}} < R_{\text{pull-up}} < \frac{V_{\text{pull-up}} - V_{\text{OH}}}{I_{\text{leak}}}$$

Where $V_{\text{pull-up}}$ is the minimum of pull-up supply, V_{OL} is the maximum of MCU logic low, R_{on} is the on resistance of the MOSFET of STATUS pin, V_{OH} is the minimum of MCU logic high, I_{leak} is the maximum leakage current of STATUS pin.

Let:

$V_{\text{pullup}} = 4.5\text{V}$; $R_{\text{on}} = V_{\text{STAT}}/I_{\text{STAT}} = 500\Omega$; $V_{\text{OL}} = 0.9\text{V}$; $V_{\text{OH}} = 2.1\text{V}$; $I_{\text{leak}} = 10\mu\text{A}$, so $2\text{k}\Omega \leq R_{\text{pull-up}} \leq 240\text{k}\Omega$.

8. Package Information

8.1. SO-8

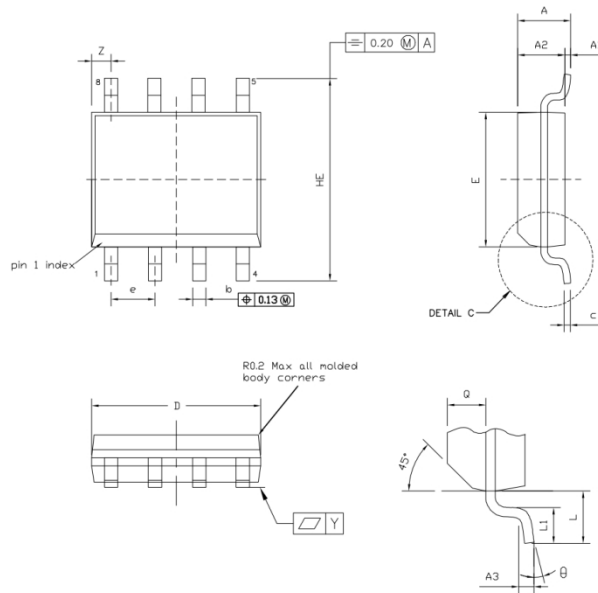

* CONTROLLING DIMENSION : MM

SYMBOL	MILLIMETER		
	MIN.	NOM.	MAX.
A	---	---	1.75
A1	0.10	---	0.25
A2	1.25	1.35	1.45
b	0.33	0.38	0.49
c	0.19	0.20	0.25
D	4.80	4.90	5.00
E	3.80	3.90	4.00
Q	0.60	0.65	0.70
HE	5.80	6.00	6.20
e	1.27 BSC		
L	1.05 BSC		
L1	0.40	0.64	1.00
Y	---	0.10	---
Z	0.3	0.5	0.7
A3	0.25 BSC		
θ	0°	5°	8°

8.2. SOT223

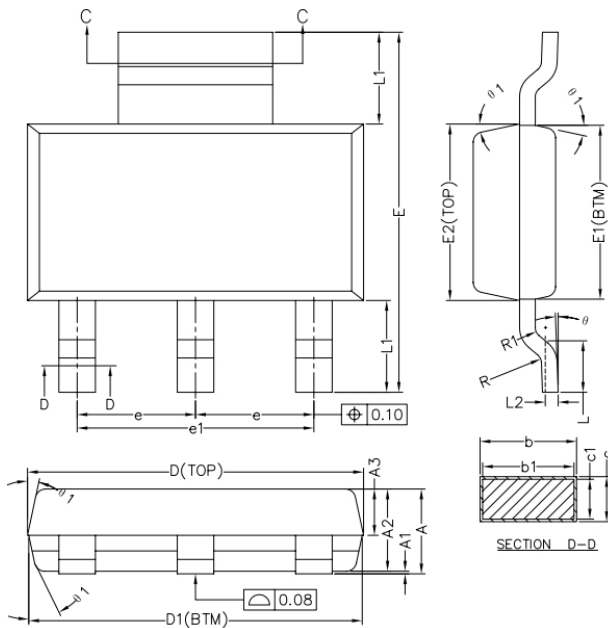

COMMON DIMENSIONS (UNITS OF MEASURE=MILLIMETER)

SYMBOL	MIN	NOM	MAX
A	—	—	1.80
A1	0.02	—	0.10
A2	1.50	1.60	1.70
A3	0.80	0.90	1.00
b	0.67	—	0.80
b1	0.66	0.71	0.76
b2	2.96	—	3.09
b3	2.95	3.00	3.05
c	0.30	—	0.35
c1	0.29	0.30	0.31
D	6.48	6.53	6.58
D1	6.43	6.48	6.53
E	6.80	—	7.20
E1	3.30	3.38	3.48
E2	3.33	3.43	3.53
e	2.25	2.30	2.35
e1	4.50	4.60	4.70
L	0.80	1.00	1.20
L1	1.78REF		
L2	0.25BSC		
R	0.10	—	—
R1	0.10	—	—
θ	0°	—	8°
θ 1	10°	12°	14°

NOTES:
ALL DIMENSIONS REFER TO JEDEC STANDARD TO261-AA
DO NOT INCLUDE MOLD FLASH OR PROTRUSIONS.
BODY LENGTH INCLUDING MOLD PROTRUSIONS SHALL NOT EXCEED 6.7mm.

9. Order Information

<i>Part Number</i>	<i>Package</i>	<i>MSL</i>	<i>Temperature</i>
NSE11409-QSPR	SOP8	3	-40 to 125°C
NSE11409-QSTBR	SOT223	3	-40 to 125°C
NOTE: All packages are RoHS-compliant			

10. Revision history

Revision	Description	Date
1V0	Initial version	2022/12