



RoHS Compliant
Directive 2011/65/EU

SPECIFICATION

Customer: ELTECH LTD

Item	Simple Packaged Crystal Oscillator (SPXO)	Receipt
Type	NP5032SA	
Nominal Frequency	125 MHz	
Customer's Spec. No.	-----	
NDK Spec. No.	END4780A	

Charge:

Sales	NDK-I A. Meroni	Tel. +39-02-96702920 e-Mail meroni@it.ndk.com
Engineer	Engineering dept. 3 Y. Oishi	Tel. +81-4-2900-6634 e-Mail q3d@ndk.com

Revision Record						
Rev.	Date	Items	Contents	Approved	Checked	Drawn
-----	22.Aug.2014	Issue	---	K.Moriya	Y.Akasaka	Y.Oishi

- 1. Customer's Spec. No. :
- 2. NDK Spec. No. : END4780A
- 3. Type : NP5032SA

4. Absolute Maximum Ratings

	Item	Ratings			Notes
		min	Max	Units	
1	Supply Voltage	-0.5	+5.0	V	
2	Storage Temp. Range	-55	+125	°C	

5. Electrical Specifications

(Unless otherwise noted, TA=0 ~ +70 °C, V_{CC}=3.3 V, Load=50 Ω)

	Parameters	SYM	Electrical Spec.				Notes
			min	typ	max	Units	
1	Nominal Frequency	f _{nom}		125		MHz	
2	Supply Voltage	V _{CC}	3.2	3.3	3.4	V	
3	Current Consumption (Operating)	I _{CC}			60	mA	at 3.3 V, 25°C
4	Current Consumption (Stand-by)	I _{ST}			30	μA	at 3.3 V, 25°C
5	Output Level	-	PECL				
6	Load	R _L			50 to V _{CC} -2V	Ω	
7	Operating Temperature Range	T _{opr}	0		+70	°C	
8	Overall Frequency Tolerance	Δf/f _{nom}	-20		+20	ppm	*1
9	Output Voltage	V _{OL}			V _{CC} -1.62	V	
		V _{OH}	V _{CC} -1.025			V	
10	Rise Time(t _r), Fall Time(t _f)	t _r /t _f			1	ns	at 20% ~ 80% Waveform
11	Symmetry	SYM	45		55	%	at 50% Waveform
12	Start-up Time	t _{su}			10	ms	
13	Output Wave Form	-	Rectangular				
14	Phase Jitter (at 3.3V, 25°C)	t _{pj}			1	ps	Offset frequency: 12kHz ~ 20MHz
15	Stand-by Function						
	#1 PAD input			# 4, 5 PAD output			
	H level (70% V _{CC} ~ V _{CC})			Operating			
	L level (30% V _{CC} max)			High impedance			

*1 Inclusive of frequency tolerance (at 25 °C), frequency/temperature characteristics, frequency/voltage coefficient

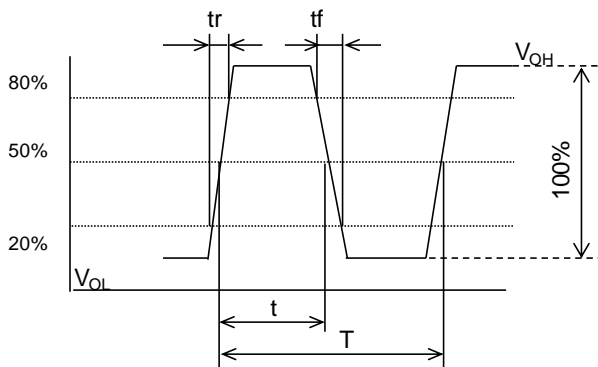

Symmetry = t/T × 100%

6. Measuring circuits

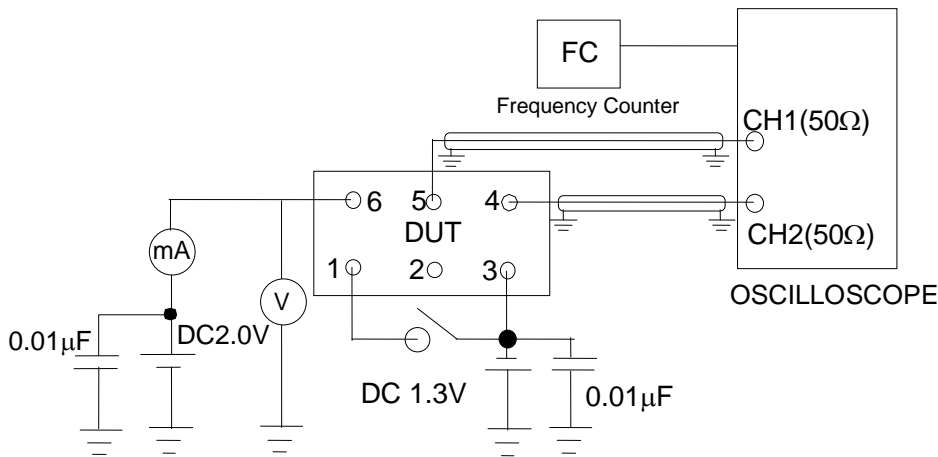

7. Test data will not be submitted

8. Application drawing

8.1 Dimension drawing

EKD14B-00055

8.2 Marking drawing

EKH11B-00111

8.3 Reliability assurance item

EKS30B-00045

8.4 Taping & Reel drawing

EKK17B-00002

9. Instruction Notice

9.1 Noise

When the NP5032S series are used, the 0.01 μ F capacitor should be connected between V_{CC} and GND line. (Closer to the product terminal is desirable.)

9.2 Resistance to dropping

The NP5032S series is designed to be impactproof so that no damage occurs. However, if dropped from a desk etc., it is advisable to check their performance or contact us to check it.

9.3 Electrostatic protection

The NP5032S series employ C-MOS ICs for the active element. Please use them in static-free environments.

9.4 Cleaning

Basically, the NP5032S series are applicable for ultrasonic wave cleaning. However, in some case, during ultrasonic wave cleanings, internal design may get damage. Please check condition carefully beforehand.

9.5 Other

The NP5032S series are C-MOS applied products. And careful handling(same as with C-MOS IC) are needed to avoid electrostatic problems.

Incorrect PAD connection is cause of trouble. Please make sure to connect correctly as below.

#3 terminal \rightarrow GND

#6 terminal $\rightarrow V_{CC}$

10. Instruction Notice

10.1 Noise

When the PECL oscillator series are used, the 0.01 μ F capacitor should be connected between V_{CC} and GND line.(Closer to the product terminal is desirable.)

10.2 Resistance to dropping

The PECL oscillator series is designed to be impactproof so that no damage occurs. However, if dropped from a desk etc., it is advisable to check their performance or contact us to check it.

10.3 Electrostatic protection

The PECL oscillator series employ C-MOS ICs for the active element. Please use them in static-free environments.

10.4 Cleaning

Basically, the PECL oscillator series are applicable for ultrasonic wave cleaning. However, in some case, during ultrasonic wave cleanings, internal design may get damage. Please check condition carefully beforehand.

10.5 Other

The PECL oscillator series are C-MOS applied products. And careful handling(same as with C-MOS IC) are needed to avoid electrostatic problems.

Incorrect PAD connection is cause of trouble. Please make sure to connect correctly as below.

#3 terminal → GND

#6 terminal → V_{CC}

11. Notice

11.1 Order items are manufactured according to specification. As to conditions, which are not indicated in this specification and unpredictable such as applied condition and oscillation margin, please check them beforehand.

11.2 Unless we receive request for modification within 3 weeks from the issue date of this NDK specification sheet, we will supply products according to this specification. Also, if you'd like to modify specification of order, which has been placed with delivery request within 3 weeks from the issue data of this specification sheet, we would like to discuss with you separately.

11.3 In no event shall the company be liable for any product failure resulting from an inappropriate handling or operation of the product beyond the scope of its guarantee.

11.4 Where any change to the process condition is made due to the change(s) in the production line, inform personnel of the specifications.

11.5 Should this specification data give rise to any disputes relating to any intellectual property rights or any other rights of a third person, the company shall not indemnify anyone for any damage. Their disclosure must not be construed as the grant of a license to use any of the intellectual property rights owned by the company.

11.6 If you intend to use products listed on this specification for applications that may result in loss of life or assets (controls relating to safety, medical equipment, aeronautical equipment, space equipment, etc.), please do not fail to advise us of your intention beforehand.

11.7 In the company's production process whatever amount of ozone depleting substances (ODS) as specified in the Montreal protocol is not used.

11.8 Information contained in this specification must not be quoted, reproduced or used for other purposes including processing either in part or in full without obtaining prior approval from the company.

11.9 The appearance color and so on have a different case by purchasing it more than 2 suppliers of the component, but characteristic and reliability are guaranteed.

12. Prohibited items

Be sure to use the product under the following conditions. Otherwise, the characteristics deterioration or destruction of the product may result.

(1)Reflow soldering heat resistance

Peak temperature: 265°C, 10 sec

Heating: 230°C or higher, 40 sec

Preheating: 150°C to 180°C, 120 sec

Reflow passage times: 3 times

(2)Manual soldering heat resistance

Press a soldering iron of 410°C on the lead electrode for 4 seconds. (twice)

Example For Soldering Conditions (The below graph corresponds to Pb free solder)

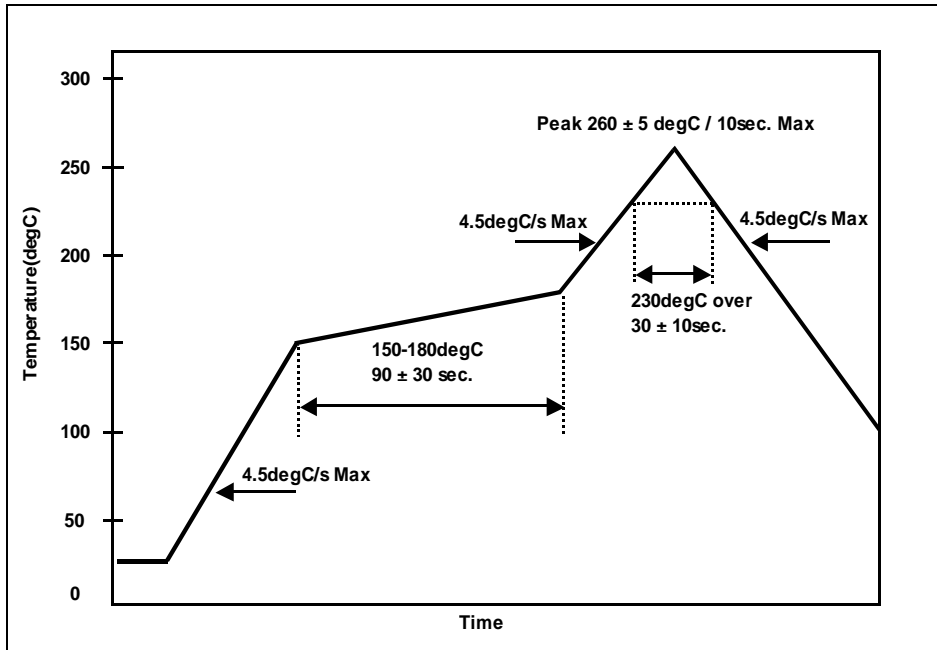

Recommended Footprint

[mm]

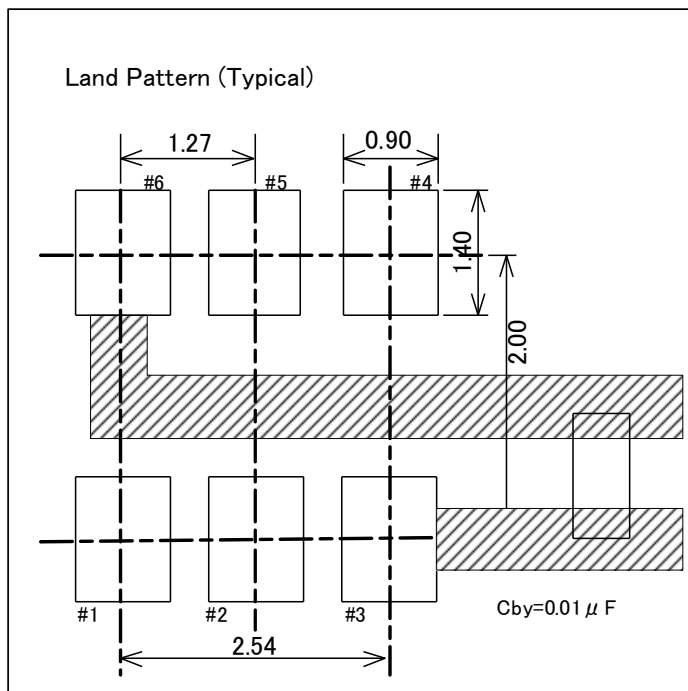

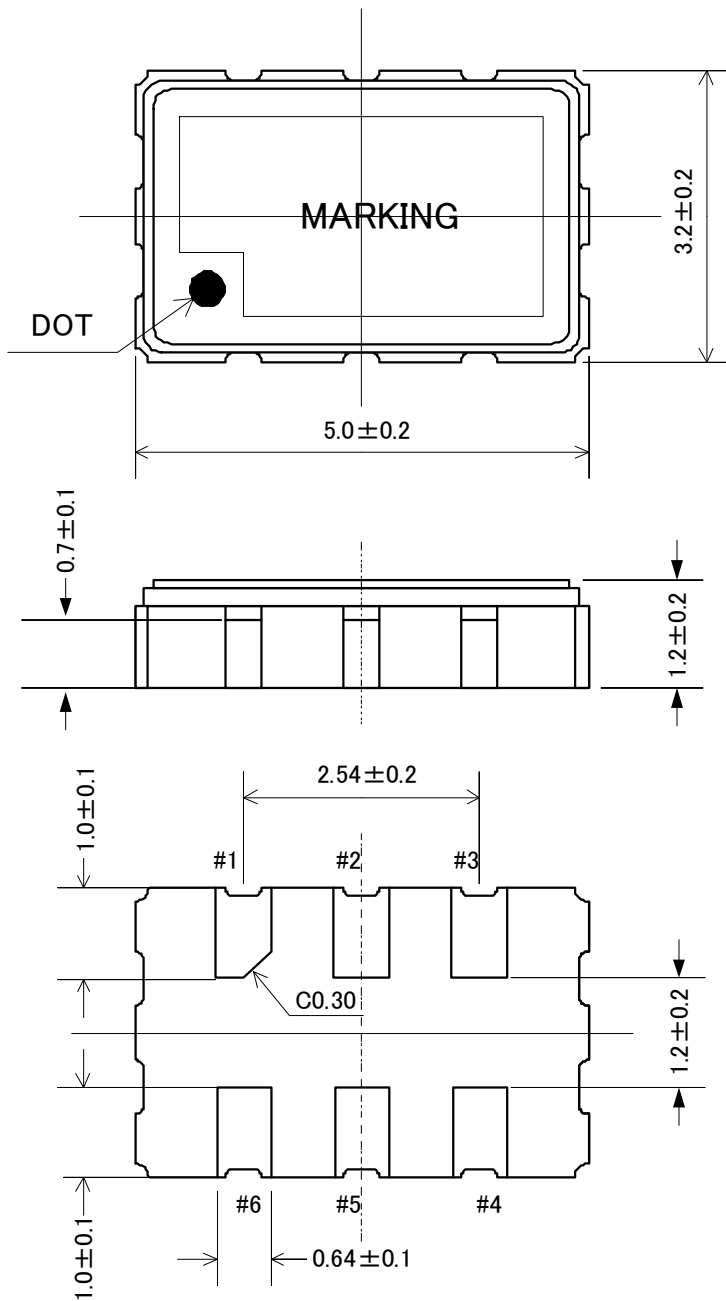

Terminal land connections

# 1	STAND-BY
# 2*1	N.C or GND
# 3	GND
# 4	Output
# 5	Complementary Output
# 6	Vcc

Note: #2 is internally connected to #3

	Date of Revise	Charge	Approved	Reason
D	Mar.14.2014	Y.Oishi	K.Moriya	Pad connections→Terminal land connections. #1 Enable/Disable→STAND-BY. Add Japanese version.
	Date	Name	Third Angle Projection	Tolerance
Drawn	May.23.2011	Y.Oishi	Dimension:mm	----
Designed	May.23.2011	K.Gen	Title	Drawing No.
Checked	May.23.2011	K.Gen		
Approved	May.23.2011	C.Ishimaru		
			Dimension of External	EKD14B-00055
				Rev.
				D

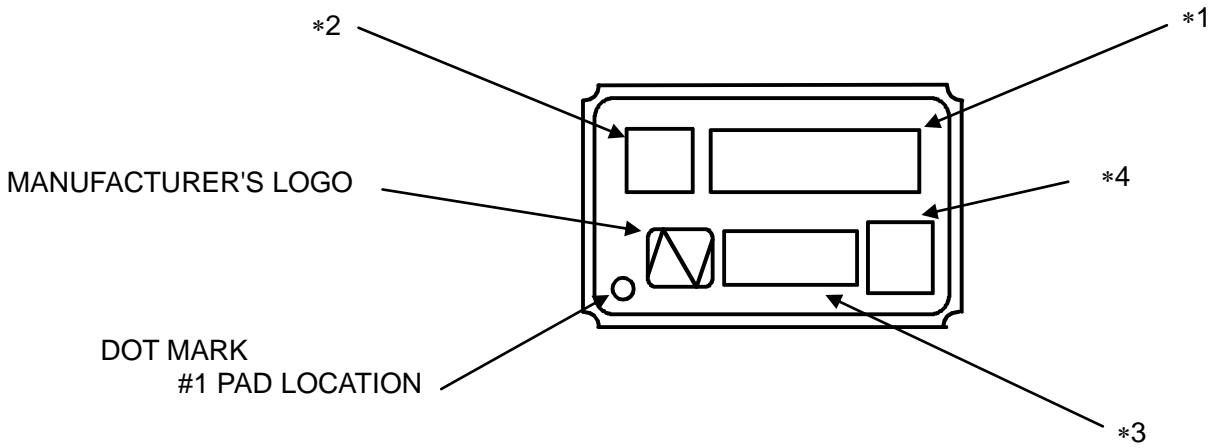

***1 [FREQUENCY]**

Digits are five and 6th digit will be omitted.
 MHz unit sign is not marked.
 ex,) 161.1328MHz → 161.132 [Unit sign not marked]

***2 [MODEL MARK]**

A last digit of model is marked.

[MODEL MARK]
NP5032SA → A
NP5032SB → B
NP5032SC → C

***3 [WEEK CODE (Digit are three)]**

ex,) In case of 43rd week of 2011

1 4 3

↑ Week No. (Digit are two)
 ↑ Lower one digit of year

***4 [Trace code]**

Trace code consists of four digits number or letter.
 This code indicates production date and production line number.

	Date of Revise	Charge	Approved	Reason
A	11.Sep.2013	Y.Oishi	Y.Akasaka	Add NP5032SC, Japanese version.
	Date	Name	Third Angle Projection	Tolerance
Drawn	Oct.27.2011	Y.Oishi	mm	-----
Designed	Oct.27.2011	K.Gen	Title NP5032 Marking	Drawing No. EKH11B-00111
Checked	Oct.27.2011	K.Gen		
Approved	Oct.27.2011	C.Ishimaru		
				Scale -----
				Rev. A

NIHON DEMPA KOGYO CO., LTD.

Environmental Test Conditions	Specification
1. Thermal Shock Test 1 cycle: -40°C (30 minutes) ~ +85°C(30 minutes) Number of cycle: 100 cycle.	*1
2. High Temperature High Humidity Test Temperature : +60°C, Humidity : 90 ~ 95%, Time : 1000 hours.	*1
3. +85°C Aging (Non Operating) Temperature : +85°C, Time : 1000 Hours.	*2
4. Vibration Test 10 ~ 55Hz, 1.52mmp-p, 1 minutes/cycle, XYZ 3 directions 2 Hours each.	*1
5. Shock Test Test condition : Half sine pulse 981m/s ² , 6ms, 3 directions: ±x, ±y, ±z, 3 times each. (18times total)	*1
6. Free Drop Test Fall height :75cm, 3 drop onto hard wooden board.	*1
7. Soldering Test Residual heat : 140~160°C, 60~120 sec, Peak 240°C, 30 ± 1 second after reaching 215 °C .	More than 90% of should be covered by solder.
8. Soldering Resistance Residual heat : 150~180°C, 60~120 sec, Peak 260± 5°C For 10sec max (230°C min 20~40 sec), 3 times.	*1
<p>*1 After a test, the electrical specifications are satisfied. Also frequency deviation before and after test should be $\Delta F/F \leq \pm 5 \times 10^{-6}$</p> <p>*2 After a test, the electrical specifications are satisfied. Also frequency deviation before and after test should be $\Delta F/F \leq \pm 10 \times 10^{-6}$</p> <p>The electrical specifications are I_{CC}, T_r/T_f, V_{OL}/V_{OH}, duty cycle, stand-by function, stand-by current consumption.</p>	

Reel

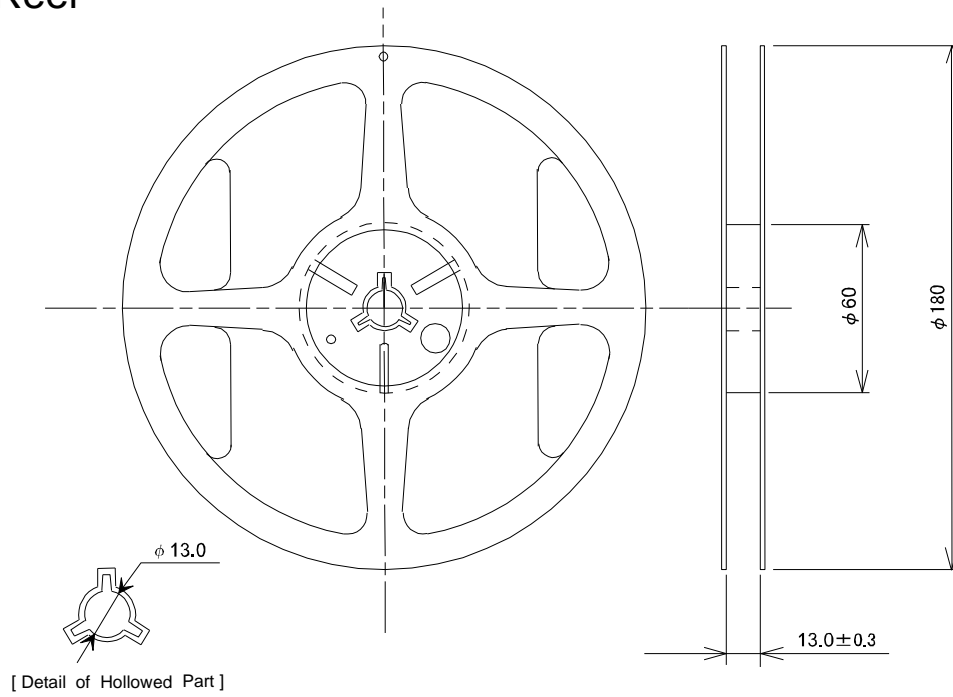

Tape

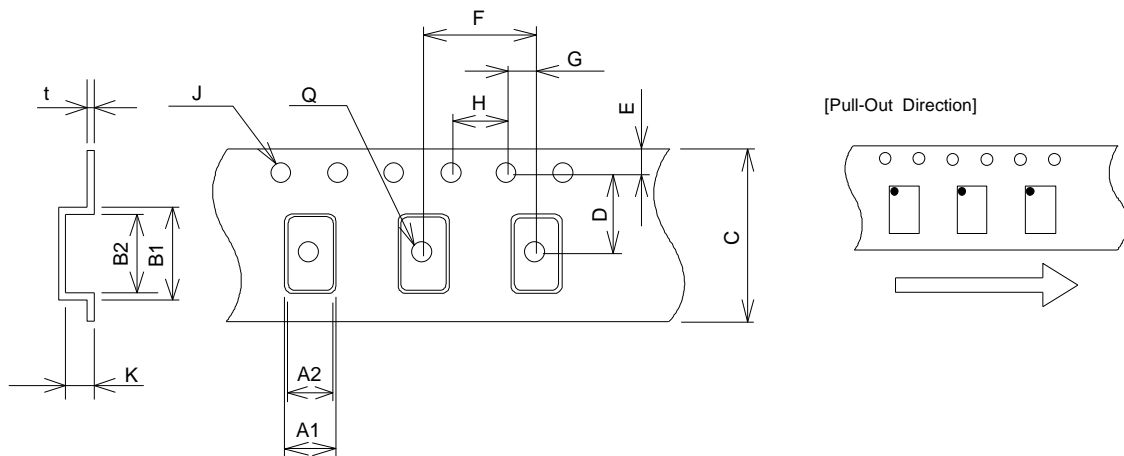

	A1	A2	B1	B2	C	D	E
Size	3.70±0.10	3.50±0.10	5.60±0.10	5.40±0.10	12.0±0.20	5.50±0.10	1.75±0.10

	F	G	H	J	K	Q	t
Size	8.00±0.10	2.00±0.10	4.00±0.10	1.50 ^{+0.1} ₋₀	1.40±0.10	1.50 ^{+0.1} ₋₀	0.30±0.05

10 pitch : 40.0±0.15mm

D and G are taken as the value between a pocket center

	Date of Revise	Charge	Approved	Reason	
A	15.Feb.2001	S.Murakami	H.Omata	Remake with the new form by a form change.	
	Date	Name	Third Angle Projection	Tolerance	Scale
Drawn	25.May.1999	N.Saito	Dimension:mm	-----	-----
Designed	25.May.1999	N.Saito	Title	Drawing No.	Rev.
Checked	25.May.1999	C.Ishimaru			
Approved	25.May.1999	H.Omata			
Packing			EKK17B-00002		A

NIHON DEMPA KOGYO CO., LTD.