

N20 Hardware Design

GPS Module Series

Version: V1.2

Date: 2016-12-15

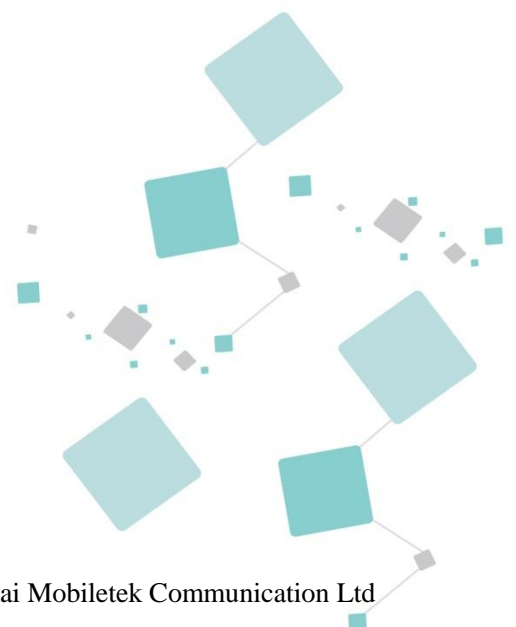

Notice

Some features of the product and its accessories described herein rely on the software installed, capacities and settings of local network, and therefore may not be activated or may be limited by local network operators or network service providers. Thus, the descriptions herein may not exactly match the product or its accessories which you purchase. Shanghai Mobiletek Communication Ltd reserves the right to change or modify any information or specifications contained in this manual without prior notice and without any liability.

Copyright

This document contains proprietary technical information which is the property of Shanghai Mobiletek Communication Ltd. copying of this document and giving it to others and the using or communication of the contents thereof, are forbidden without express authority. Offenders are liable to the payment of damages. All rights reserved in the event of grant of patent or the registration of a utility model or design. All specification supplied herein are subject to change without notice at any time.

DISCLAIMER

ALL CONTENTS OF THIS MANUAL ARE PROVIDED "AS IS". EXCEPT AS REQUIRED BY APPLICABLE LAWS, NO WARRANTIES OF ANY KIND, EITHER EXPRESS OR IMPLIED, INCLUDING BUT NOT LIMITED TO, THE IMPLIED WARRANTIES OF MERCHANTABILITY AND FITNESS FOR A PARTICULAR PURPOSE, ARE MADE IN RELATION TO THE ACCURACY, RELIABILITY OR CONTENTS OF THIS MANUAL. TO THE MAXIMUM EXTENT PERMITTED BY APPLICABLE LAW, IN NO EVENT SHALL SHANGHAI MOBILETEK COMMUNICATION LTD BE LIABLE FOR ANY SPECIAL, INCIDENTAL, INDIRECT, OR CONSEQUENTIAL DAMAGES, OR LOSS OF PROFITS, BUSINESS, REVENUE, DATA, GOODWILL SAVINGS OR ANTICIPATED SAVINGS REGARDLESS OF WHETHER SUCH LOSSES ARE FORSEEABLE OR NOT.

Version History

Date	Version	Modify records	Author
2016-09-05	V1.0	First release	Xuliangbo
2016-10-17	V1.1	Optimized layout format	Xuliangbo
2016-12-15	V1.2	Modify Dimensions Information	Xuliangbo

Content

1.	Introduction.....	5
2.	N20 Overview.....	5
2.1	N20 Functional Diagram.....	6
2.2	GPS Performance.....	7
2.3	General features.....	8
3.	Package Information.....	10
3.1	Pin out Diagram.....	10
3.2	Pin Description.....	10
3.3	Package Dimensions.....	12
3.4	N20 Recommended PCB Decal.....	12
4.	Application Interface.....	14
4.1	Power Management.....	14
4.1.1	Power Input.....	14
4.1.2	Starting N20.....	14
4.1.3	Verification of N20 Start.....	14
4.1.4	Power Saving Modes.....	14
4.1.5	Operating Mode.....	15
4.1.6	VCC_RF.....	17
4.1.7	ANTON.....	17
4.2	UART Interface.....	17
4.3	RESET_N Input.....	17
4.4	TIMEPULSE Output.....	18
4.5	A-GPS and DGPS.....	18
4.5.1	EPO.....	18
4.5.2	DGPS.....	18
4.5.3	EASY™.....	19
4.6	GPS Antenna.....	19
4.6.1	Antenna Interface.....	20
4.6.2	Antenna Choice and RF Design Consideration.....	20
5.	Electrical, Reliability and Radio Characteristics.....	25
5.1	Absolute Maximum Ratings.....	25
5.2	Recommended Operating Conditions.....	25
5.3	Electro-Static Discharge.....	26
6.	Manufacturing.....	28
6.1	Top and Bottom View of N20.....	28

6.2 Assembly and Soldering28

6.3 Moisture sensitivity29

6.4 ESD handling precautions30

6.5 Shipment.....31

7. Reference Design32

Appendix.....33

 A. Related Documents.....33

 B. Terms and Abbreviations.....33

LYNQ
CONFIDENTIAL

1. Introduction

This document describes the hardware interface of the MOBILETEK module N20 which can be used as a stand-alone GPS or A-GPS (Assisted Global Positioning System) receiver. As a wide range of applications can be integrated in N20, all functional components of N20 are described in great detail.

2. N20 Overview

N20 is a stand-alone GPS or A-GPS receiver. With built-in LNA, N20 can relax antenna requirement and don't need for external LNA. N20 can track as low as -165dBm signal level. The N20 has excellent low power consumption characteristic (acquisition 18mA, tracking 16mA). N20 supports various location and navigation applications, including autonomous GPS, QZSS, SBAS ranging (WAAS, EGNOS, GAGAN, MSAS), RTCM and A-GPS.

Key Features

- GPS receiver, supports QZSS, SBAS ranging, supports WAAS/EGNOS/MSAS/GAGAN
- 22 tracking/66 acquisition-channel, up to 210 PRN channels
- Small footprint: 16x 12.2 x 2.5mm, 24-pin LCC package
- 12 multi-tone active interference cancellers and jamming elimination
- Indoor and outdoor multi-path detection and compensation
- Max NMEA update rate up to 5 HZ
- Advanced software features
 1. EPO orbit prediction
 2. AlwaysLocate advanced location awareness technology
 3. supports logger function

- 4. supports active interference cancellation (AIC)
- Pulse-per-second (PPS) GPS time reference
 1. Adjustable duty cycle
 2. typical accuracy: $\pm 10\text{ns}$
- Interface
 - UART
- Operating temperature: $-40^{\circ}\text{C} \sim +85^{\circ}\text{C}$
- Accuracy 2.5m CEP
- RoHS compliant

The module provides complete signal processing from antenna input to host port in either NMEA messages. The module requires 2.8V~4.3V power supply. The host port is configurable to UART. Host data and I/O signal levels are 2.85V CMOS compatible.

2.1 N20 Functional Diagram

The following figure shows a functional diagram of the N20 and illustrates the mainly functional parts:

- The GPS chip
- SAW filter
- LNA
- The antenna interface
- The communication interface
- The control signals

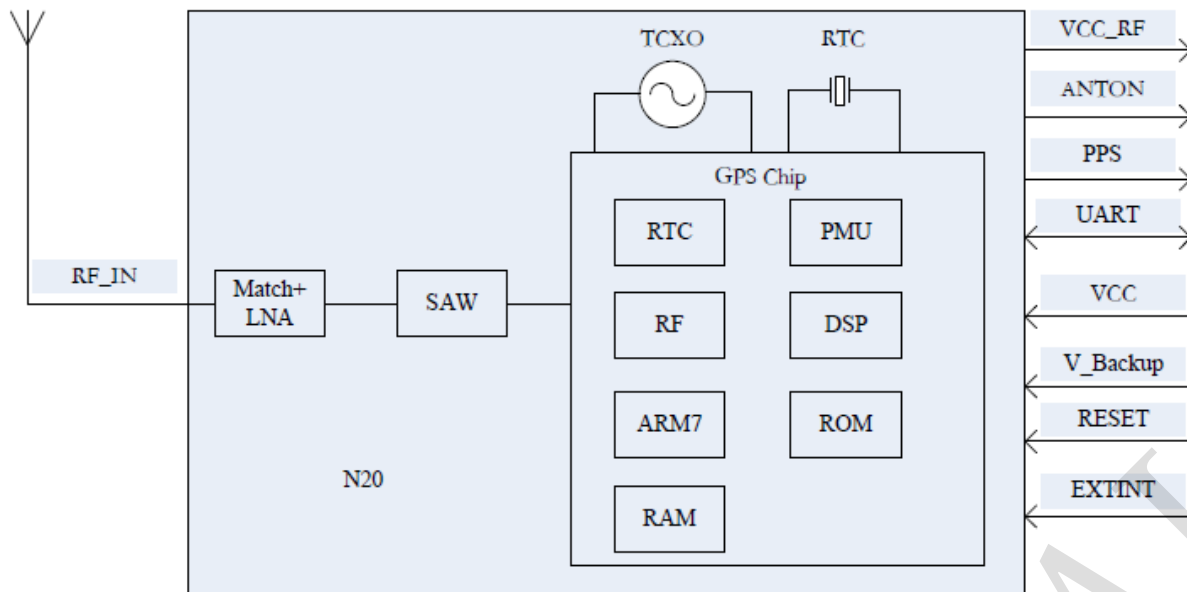

Figure 1 N20 functional diagram

2.2 GPS Performance

Table 1 GPS performance

Parameter	Description	Performance			
		Min	Type	Max	Unit
Horizontal Position Accuracy ⁽¹⁾	Autonomous		<2.5		m
Velocity Accuracy ⁽²⁾	Without Aid		0.1		m/s
	DGPS		0.05		m/s
Acceleration Accuracy	Without Aid		0.1		m/s ²
	DGPS		0.05		m/s ²
Timing Accuracy			10		ns
Dynamic Performance	Maximum Altitude			18000	m
	Maximum Velocity			515	m/s
	Maximum Acceleration			4	G

Time To First Fix ⁽³⁾	Hot start		<1		s
	Warm start		30		s
	Cold start		32		s
A-GPS TTFF(EPO mode)	Hot start		<1		s
	Warm start		2		s
	Cold start		15		s
Sensitivity ⁽³⁾	Autonomous acquisition(cold start)		-148		dBm
	Re-acquisition		-160		dBm
	Tracking		-165		dBm
Receiver	Channels		22 tracking/66 acquisition		
	Update rate		1	5	Hz
	Tracking L1, CA Code				
	Protocol support NMEA,PMTK				
Power consumption ⁽⁴⁾	Acquisition		18		mA
	Continuous tracking		16		mA
	Sleep current		340		uA
	Backup current		8		uA

(1) 50% 24hr static, -130dBm

(2) 50% at 30m/s

(3) GPS signal level: -130dBm

(4) Single Power supply 3.3V@-130dBm

2.3 General features

Table 2 General features

Parameters	Value	
Supply voltage VCC	2.8V~4.3V	
Supply voltage ripple VCC	54 mV(RMS) max @ f = 0~3MHz 15 mV(RMS) max @ f > 3 MHz	
Power consumption(acquisition)	18 mA type. @ VCC=3.3 V	
Power consumption(sleep)	340 uA type. @ VCC=3.3 V	
Storage temperature	-40 ℃~+125 ℃	
Operating temperature	-40 ℃~+85 ℃ (note 1)	
I/O signal levels	V _{IL}	-0.3V~0.8V
	V _{IH}	2.0V~3.6V
	V _{OL}	-0.3V~0.4V
	V _{OH}	2.4V~3.1V
I/O output sink/source capability	+/- 3mA max	
I/O input leakage	+/- 10 uA max	
Host port	UART0	
Serial port protocol (UART)	NMEA; 8 bits, no parity, 1 stop bit; 9600 baud	

Note 1: Operation in the temperature range -40℃~ -30℃ is allowed but Time-to-First-Fix performance and tracking sensitivity may be degraded.

3. Package Information

3.1 Pin out Diagram

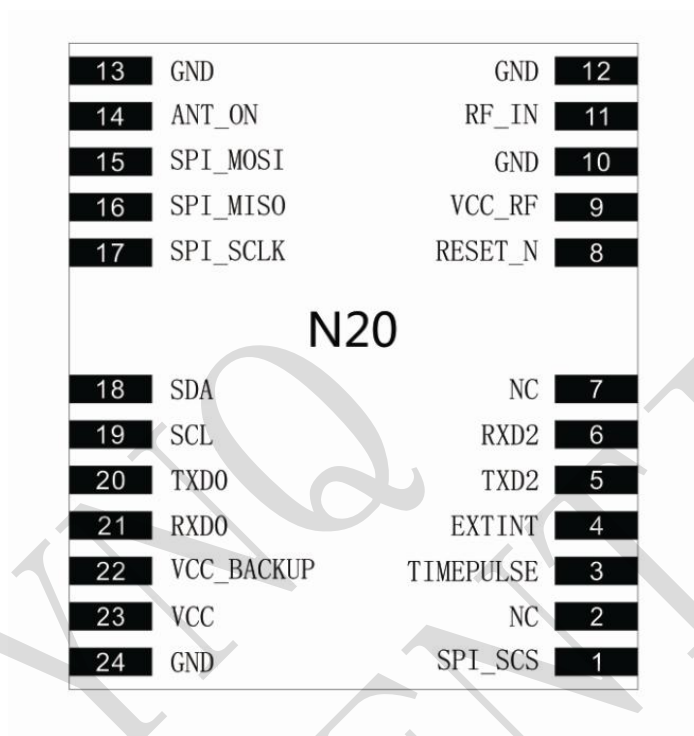

Figure 2 N20 pin out diagram (Top view)

3.2 Pin Description

Table 3 Pin description

Pin name	Pin number	I/O	Description	Comment
Power supply				
VCC	23	I	Main power input, Typical: 3.3V. The Vcc ripple must be controlled under 54mVpp	Add a 4.7uF capacitor to this pin for decoupling
ANTON	14	O	2.8V power output supply for active antenna or external LNA control pin for power save	If unused, keep open
VCC_RF	9	O	Power supply for active	If unused, keep open

			antenna or external LNA	
VCC_BACKUP	22	I	The backup battery input power supply for RTC 2.0V~4.3V, Typical 3.0V	If unused, keep open
GND	10,12,13,24		Ground	
Host port interface				
TXD0	20	O	Serial data output of NMEA	
RXD0	21	I	Serial data input for firmware update	
TXD2	5	I/O	Serial output as RTCM	
RXD2	6	I	Serial input as RTCM	
SDA	18	I/O	Serial data output of NMEA	IIC requires a special version, please contact MOBILETEK
SCL	19	I	Serial data input for firmware update	
SPI_SCS	1	I	Chip select	SPI requires a special version, please contact MOBILETEK
SPI_MOSI	15	I	Master out line, Slave in line	
SPI_MISO	16	O	Master in line, Slave out line	
SPI_SCLK	17	I	Chip clock	
GPIOs				
TIMEPULSE	3	O	1PPS Time Mark Output 2.85V CMOS Level ,timing pulse related to receiver time	If unused, keep open
RESET_N	8	I	Reset input, active low, default pull-up	If unused, keep open
EXTINT	4	I	This interrupt source could act as wake up event during power saving mode	If unused, keep open
RF interface				
RF_IN	11	I	GNSS antenna port	Impedence must be controlled to 50Ω
Other interface				

NC	2,7	Not Connected
----	-----	---------------

3.3 Package Dimensions

Following figure shows the Mechanical dimensions of N20 (top view, side view and bottom view).

Figure 3 N20 mechanical dimensions (Unit: mm)

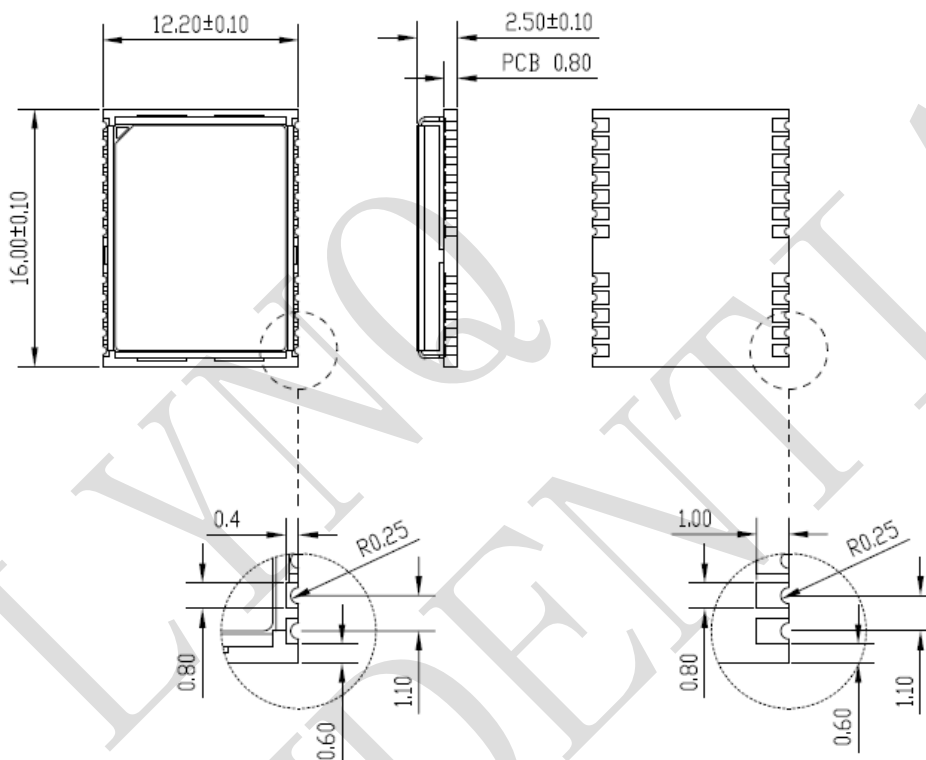

3.4 N20 Recommended PCB Decal

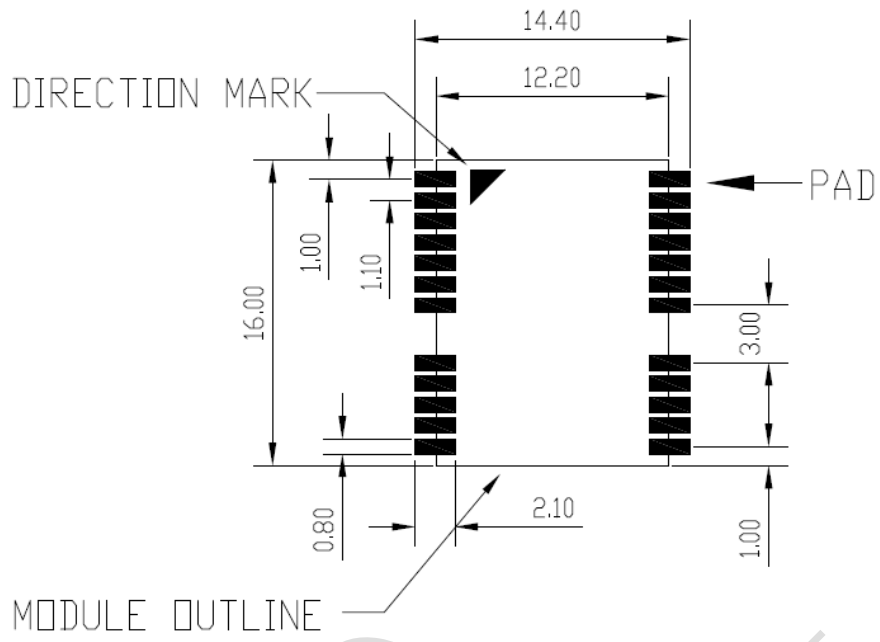

Figure 4 Recommended PCB decal (top view) (Unit: mm)

4. Application Interface

4.1 Power Management

4.1.1 Power Input

The power supply range of N20 is from 2.8V to 4.3V. The power supply should be able to provide sufficient current up to 100mA.

The power supply range of V_BACKUP is from 2V to 4.3V, typical 3.0V, suggest customer keep the V_BACKUP supply active all the time, the module will perform a quick start every time it is power-on.

4.1.2 Starting N20

When power is first applied, N20 goes into operation mode.

4.1.3 Verification of N20 Start

System activity indication depends upon the chosen serial interface: when it is activated, N20 will output messages at the selected UART speed and message types.

4.1.4 Power Saving Modes

N20 supports operating modes for reduced average power consumption like standby mode, backup mode, periodic mode, and AlwaysLocate™ mode.

- **Sleep mode:** In this mode the receiver stays at full on power state. When this mode that can be wake up by the host sends the command through the communication interface.
- **Backup mode:** In this mode the N20 must be supplied by the V_BACKUP pin and the VCC power should be cut off. The module could not achieve this mode through PMTK commands.

- **Periodic mode:** In this mode the N20 enters tracking and sleep mode according to the interval configured.
- **AlwaysLocate™ mode:** AlwaysLocate™ is an intelligent controller of N20 periodic mode. Depending on the environment and motion conditions, N20 can adaptive adjust the on/off time to achieve balance of positioning accuracy and power consumption.

Note: the modes mentioned above are operated by PMTK commands, users can refer to document [1] for more information.

N20 provides very low leakage battery back up memory, which contains all the necessary GPS information for quick start up and a small amount of user configuration variables. It needs a 3V power supply for V_BACKUP pin.

4.1.5 Operating Mode

Table 4 Power supply and clock state according to operation mode

Mode	VCC	V_BACKUP	Internal LDO	Main clock	RTC clock
Full on	on	on	on	on	on
Sleep	on	on	on	off	On
Backup	on	on	off	off	on

Full on Mode

The module will enter full on mode after first power up with factory configuration settings. Power consumption will vary depending on the amount of satellite acquisitions and number of satellites in track.

Sleep Mode

Sleep mode means a low quiescent (350uA type.) power state, non-volatile RTC, and backup RAM

block is powered on. Other internal blocks like digital baseband and RF are internally powered off. The power supply input VCC shall be kept active all the time, even during sleep mode. Entering into sleep mode is sent PMTK command through the communication interface by host side. Waking up from sleep mode is sent any byte through the communication interface by host side.

Backup Mode

This connects to the backup power of the module. Power source (such as battery or cap) connected to V_BACKUP pin will help the chipset in keeping its internal RTC running when the VCC power source is turned off. The voltage should be kept between 2.0~4.3V, Typical 3.0V.

The V_BACKUP power should be kept active all the time, the module will perform a quick start every time it is power-on.

Periodic Mode

In this mode the N20 enters tracking and sleep mode according to the interval configured by users in the commands.

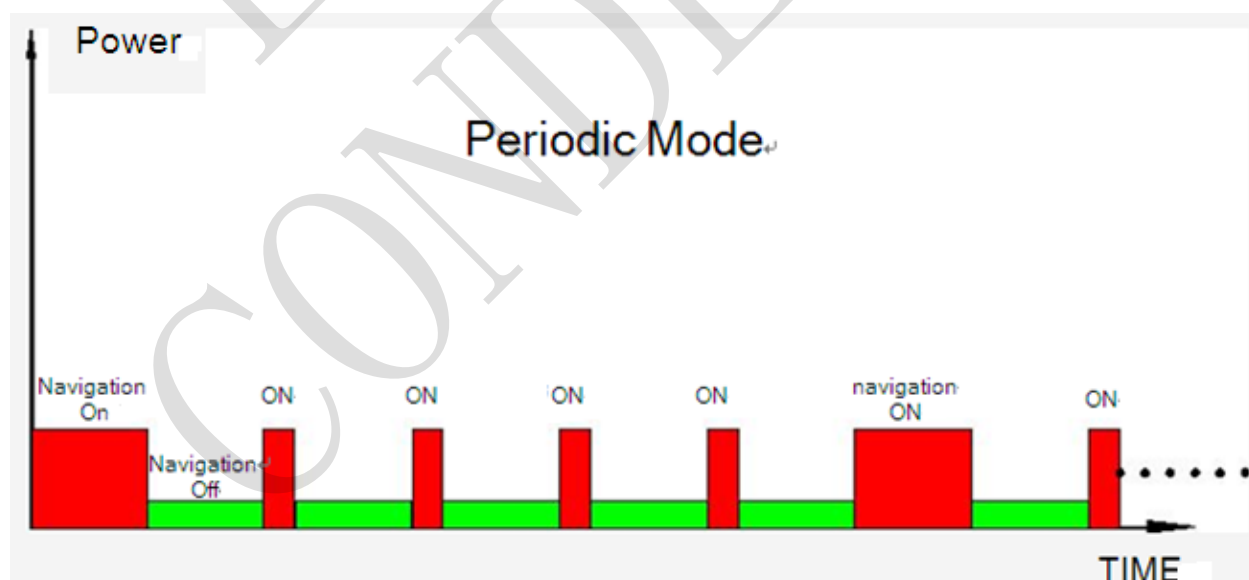

Figure 5 Periodic Mode

4.1.6 VCC_RF

Power supply for active antenna or external LNA, the power domain is 2.8V.

4.1.7 ANTON

2.8V power output for active antenna or external LNA control pin for power save. See the following table for details.

Table 5 ANTON Status

Mode	ANTON
Full on	2.8V power output
Sleep	no power output
Backup	no power output

4.2 UART Interface

N20 includes two UART (UART0 and UART1) interfaces for serial communication. The UART0 is as NEMA output and PMTK command input. The receiver (RXD0) and transmitter (TXD0) side of every port contains a 16-byte FIFO and has 256 bytes URAM. UART can provide the developers signal or message outputs. The baud rate is 9600 kbps. UART1 is as RTCM input.

4.3 RESET_N Input

The NRESET pin (active low) is used to reset the system, normally external control of NRESET is not necessary. The signal can be left floating, if not used.

When NRESET signal is used, it will force volatile RAM data loss. Note that Non-Volatile backup RAM content is not cleared and thus fast TTFB is possible. The input has internal pull up.

4.4 TIMEPULSE Output

The TIMEPULSE pin outputs one pulse-per-second (1PPS) pulse signal for precise timing purposes. The TIMEPULSE signal can be provided through designated output pin for many external applications. This pulse is not only limited to be active every second but also allowed to set the required duration, frequency, and active high/low by programming user-defined settings.

4.5 A-GPS and DGPS

A-GPS is the meaning of Assisted GPS, which is a system that can improve the startup performance, and time-to-first-fix (TTFF) of a GPS satellite-based positioning under certain conditions. N20 module supports EPO file, SBAS, RTCM.

4.5.1 EPO

The N20 supports the EPO (Extended Prediction Orbit) data service. The EPO data service is supporting 6 hours orbit predictions to customers. It need occasional download from EPO server. Supply of aiding information like ephemeris, almanac, rough last position and time and satellite status and an optional time synchronization signal will reduce time to first fix significantly and improve the acquisition sensitivity.

The user should update the EPO files from the EPO server daily through the internet. Then the EPO data should send to the N20 by the HOST side. N20 has the short cold TTFF and warm TTFF, when the A-GPS is used.

Note: For more information about EPO, please contact Insislink sales. users can refer to document [2] for more information.

4.5.2 DGPS

SBAS is the abbreviation of Satellite Based Augmentation System. The SBAS concept is based on

the transmission of differential corrections and integrity messages for navigation satellites that are within sight of a network of reference stations deployed across an entire continent. SBAS messages are broadcast via geostationary satellites able to cover vast areas.

Several countries have implemented their own satellite-based augmentation system. Europe has the European Geostationary Navigation Overlay Service (EGNOS) which covers Western Europe and beyond. The USA has its Wide Area Augmentation System (WAAS). Japan is covered by its Multi-functional Satellite Augmentation System (MSAS). India has launched its own SBAS program named GPS and GEO Augmented Navigation (GAGAN) to cover the Indian subcontinent.

N20 module supports SBAS and RTCM, but only one mode can be applied at one time, and SBAS is the default feature, customers who want to apply RTCM in the design can contact Insislink sales for supporting.

4.5.3 EASY™

N20 supports EASY™(Embedded Assisted System) is Self-Generated Orbit Prediction feature. By comparison EPO/Hot Still/AGPS, it provides up to 3 days GPS orbit prediction ability without any host CPU portioning or internet connection requirement.

4.6 GPS Antenna

The antenna is a critical item for successful GPS reception in a weak signal environment. Proper choice of the antenna will ensure that satellites at all elevations can be seen, and therefore, accurate fix measurements are obtained.

It is recommended to use a Passive Antenna. If the antenna interface is far away from N20 module, can use an active antenna .e.g. the customer's design is for automotive applications

It is suggested the antenna should be chosen as following:

Table 6 Antenna Specifications

Parameter	Specification	
Passive Antenna Recommendations	Frequency range	1575 ±3MHz
	Polarization	RHCP&Linear
	Gain	>0dBi
Active Antenna Recommendations	Frequency range	1575 ±3MHz
	Polarization	RHCP&Linear
	Noise Figure	<1.5dB
	Gain	>20dBi

4.6.1 Antenna Interface

The N20 receives L1 band signals from GPS satellites at a nominal frequency of 1575.42 MHz. The RF signal is connected to the RF_IN pin. And the trace from RF_IN to antenna should be 50Ω controlled.

To suit the physical design of individual applications the RF interface pad can lead to two alternatives:

- Recommended approach: solderable RF coaxial cable assembly antenna connector, such as HRS'U.FL-R-SMT(10) connector or I-PEX's 20279-001E-01 RF connector.
- SMA connector.

4.6.2 Antenna Choice and RF Design Consideration

To obtain excellent GPS reception performance, a good antenna will always be required. The RF circuits should also be designed properly based on the type of antenna.

Passive Antenna

Passive antenna contains only the radiating element, e.g. the ceramic patch, the helix structure, and

chipantennas. Sometimes it also contains a passive matching network to match the electrical connection to 50 Ω impedance.

The most common antenna type for GPS applications is the patch antenna. Patch antennas are flat, generally have a ceramic and metal body and are mounted on a metal base plate.

Figure 6 shows a minimal setup for a GPS receiver with N20 module.

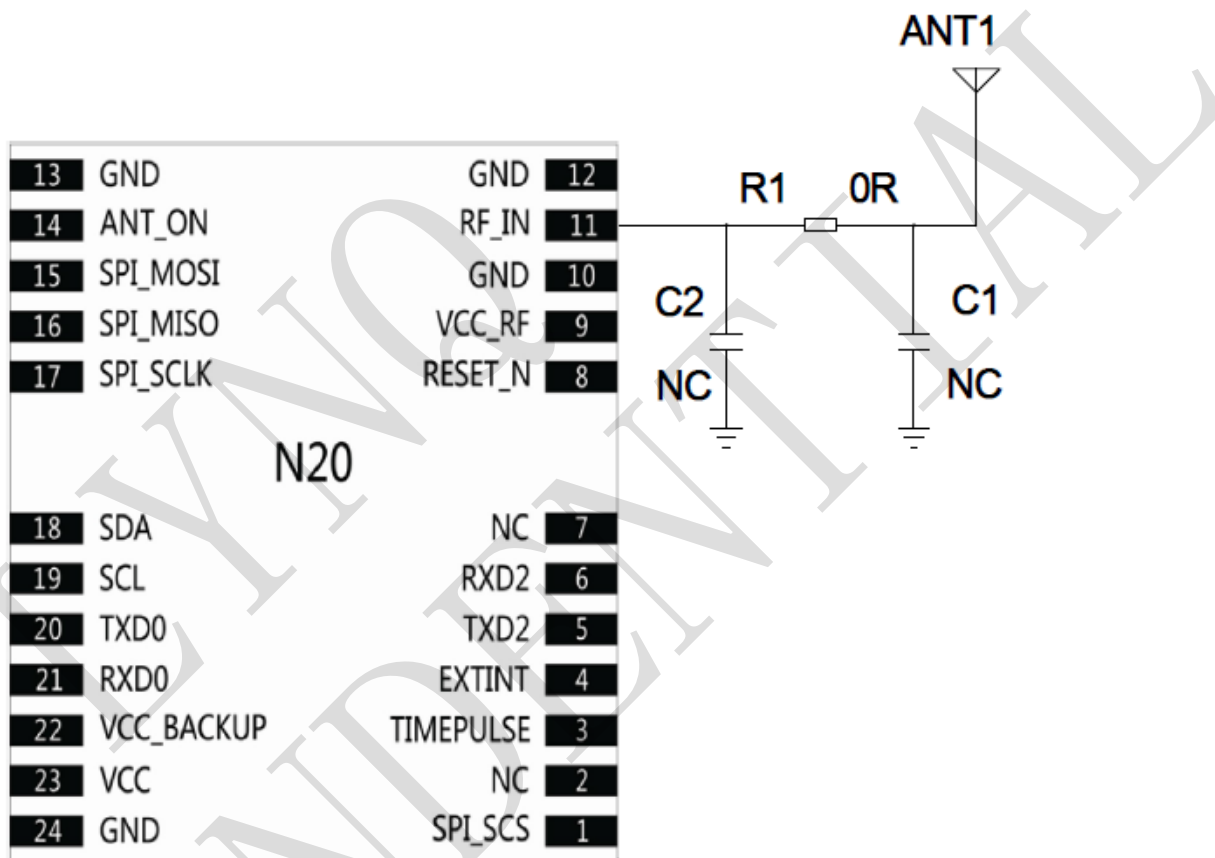

Figure 6 N20 passive antenna designs

Note: Module with built-in LNA to reach total receiver chain NF to 0.79dB, you do not need external LNA.

If the electromagnetic environment of module is very complicated, eg coexisted with GSM, UMTS, WLAN and Bluetooth, user can use a saw (IL<1.4dB) to increase the sensitivity. Please see Figure 7.

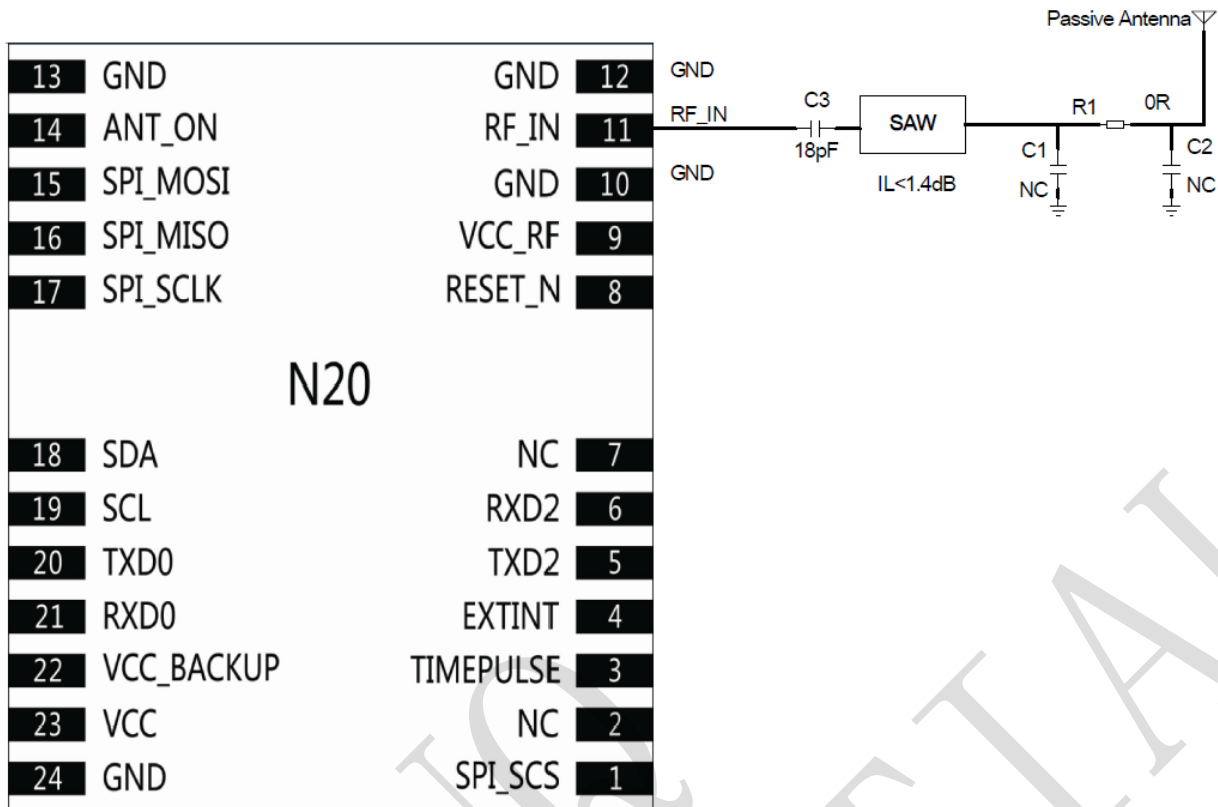

Figure 7 N20 passive antenna designs(with external saw)

Active Antennas

Active antennas have an integrated Low-Noise Amplifier (LNA). Active antennas need a power supply that will contribute to GPS system power consumption.

- Usually Pin 9 VCC_RF is directly used for the active antenna power input, as shown in Figure 8. The voltage range is from 2.8V to 4.3V, typical value is 2.8V, and the max driver current is 100mA. If the VCC_RF voltage does not meet the requirements for powering the active antenna, an external LDO should be used. The inductor L1 is used to prevent the RF signal from leaking into the VCC_RF pin and route the bias supply to the active antenna, the recommended value of L1 is no less than 27nH. R2 can protect the whole circuit in case the active antenna is shorted to ground.

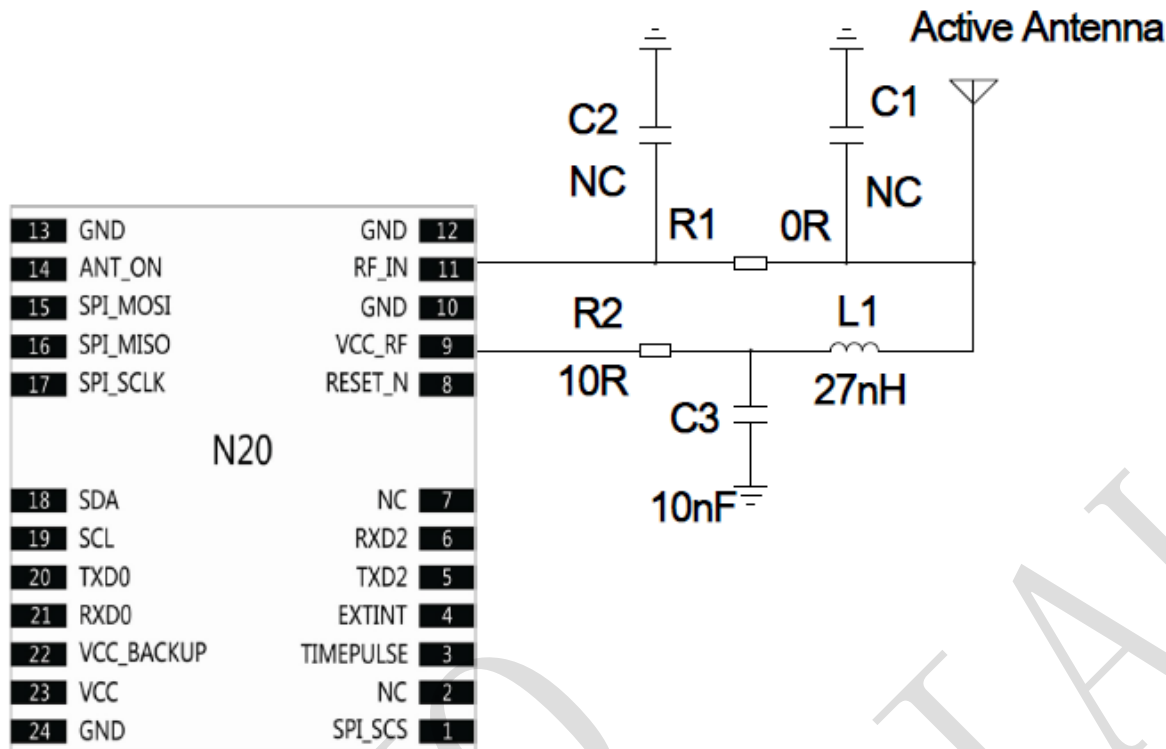

Figure 8 N20 Active antenna simplified design

Note: Active Antenna LNA receiver chain NF must less than 1dB, Gain less than 20dB. Power consumption is determined by the customer to select the LNA mode (Recommend:BG524N6).

- N20 can also reduce power consumption by controlling the power supply of active antenna by pin 14 ANTON as shown in Figure 9. ANTON is an optional pin which can be used to control the power supply of the active antenna or the enable pin of an external LNA. When N20 module enters the standby mode, the ANTON pin will be pulled down, MOSFET Q1 and Q2 are in high impedance state and the power supply for antenna is cut off. In normal mode, the voltage value of ANTON is about 2.8V, it will make Q1 and Q2 in the on-state, VCC_RF will provide power supply for the active antenna. If not used, please keep ANTON pin open. For minimizing the current consumption, the value of resistor R2 should not be too small, and the recommended value is 10KR.

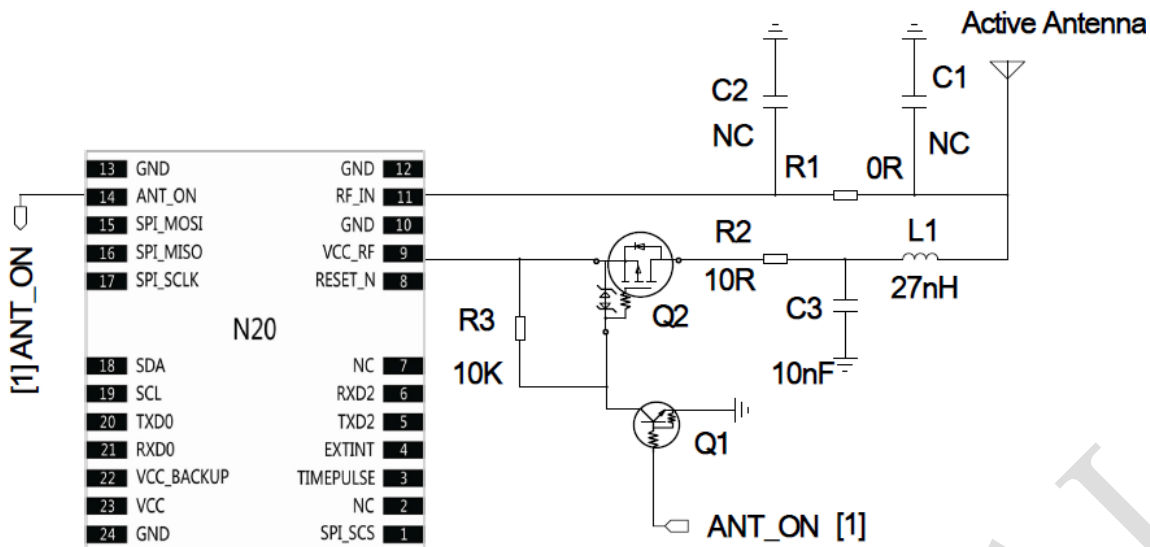

Figure 9 N20 Active antenna power consumption saving design

If the customer’s design is for automotive applications, then an active antenna can be used and located on top of the car in order to guarantee the best signal quality.

GPS antenna choice should base on the designing product and other conditions. For detailed Antenna designing consideration, please refer to related antenna vendor’s design recommendation. The antenna vendor will offer further technical support and tune their antenna characteristic to achieve successful GPS reception performance depending on the customer’s design.

5. Electrical, Reliability and Radio Characteristics

5.1 Absolute Maximum Ratings

The absolute maximum ratings stated in Table 7 are stress ratings under non-operating conditions.

Stresses beyond any of these limits will cause permanent damage to N20.

Table 7 Absolute maximum ratings

Parameter	Min	Max	Unit
VCC		4.3	V
VCC_RF		VCC	V
ANTON		+2.9	V
Input Power at GNSS_ANT		-12	dBm
V_BACKUP		4.3	V
I/O pin voltage		3.6	V
Storage temperature	-45	+125	°C
Operating Temperature	-40	+85	°C

5.2 Recommended Operating Conditions

Table 8 N20 operating conditions

Parameter	Symbol	Min	Type	Max	Unit
Operating temperature range		-40	+25	+85	°C
Main supply voltage	VCC	2.8	3.3	4.3	V
Backup battery voltage	V_BACKUP	2.0	3	4.3	V

Table 9 N20 standard IO features

Parameter	Symbol	Min	Type	Max	Unit
Low level output voltage Test conditions IOL = 2mA and 4.0mA	VOL		0	0.40	V
High level output voltage Test conditions IOL = 2mA and 4.0mA	VOH	2.4	2.8		V
Low level input voltage	VIL	-0.3		0.8	V
High level input voltage	VIH	2.0		3.6	V
Input Pull-up resistance	RPU	40		190	KΩ
Input Pull-down resistance	RPD	40		190	KΩ
Input capacitance	CIN		5		pF
Load capacitance	Cload			8	pF
Tri-state leakage current	IOZ	-10		10	uA

5.3 Electro-Static Discharge

The GPS engine is not protected against Electrostatic Discharge (ESD) in general. Therefore, it is subject to ESD handling precautions that typically apply to ESD sensitive components. Proper ESD handling and packaging procedures must be applied throughout the processing, handling and operation of any application using a N20 module. The ESD test results are shown in the following table.

Table 10 The ESD characteristics (Temperature: 25°C, Humidity: 45 %)

Pin	Contact discharge	Air discharge
VCC	±5KV	±10KV
RF_IN	±5KV	±10KV
VCC_BACKUP	±5KV	±10KV
ANTON	±5KV	±10KV

VCC_RF	±5KV	±10KV
GND	±5KV	±10KV
RXD0,TXD0	±4KV	±8KV
RESET_N	±4KV	±8KV
TIMEPULSE	±4KV	±8KV

LYNQ
CONFIDENTIAL

6. Manufacturing

6.1 Top and Bottom View of N20



Figure 10 Top and bottom view of N20

6.2 Assembly and Soldering

The N20 module is intended for SMT assembly and soldering in a Pb-free reflow process on the top side of the PCB. Suggested solder paste stencil height is 150um minimum to ensure sufficient solder volume. If required paste mask pad openings can be increased to ensure proper soldering and solder wetting over pads. The following figure is the Ramp-Soak-Spike Reflow Profile of N20:

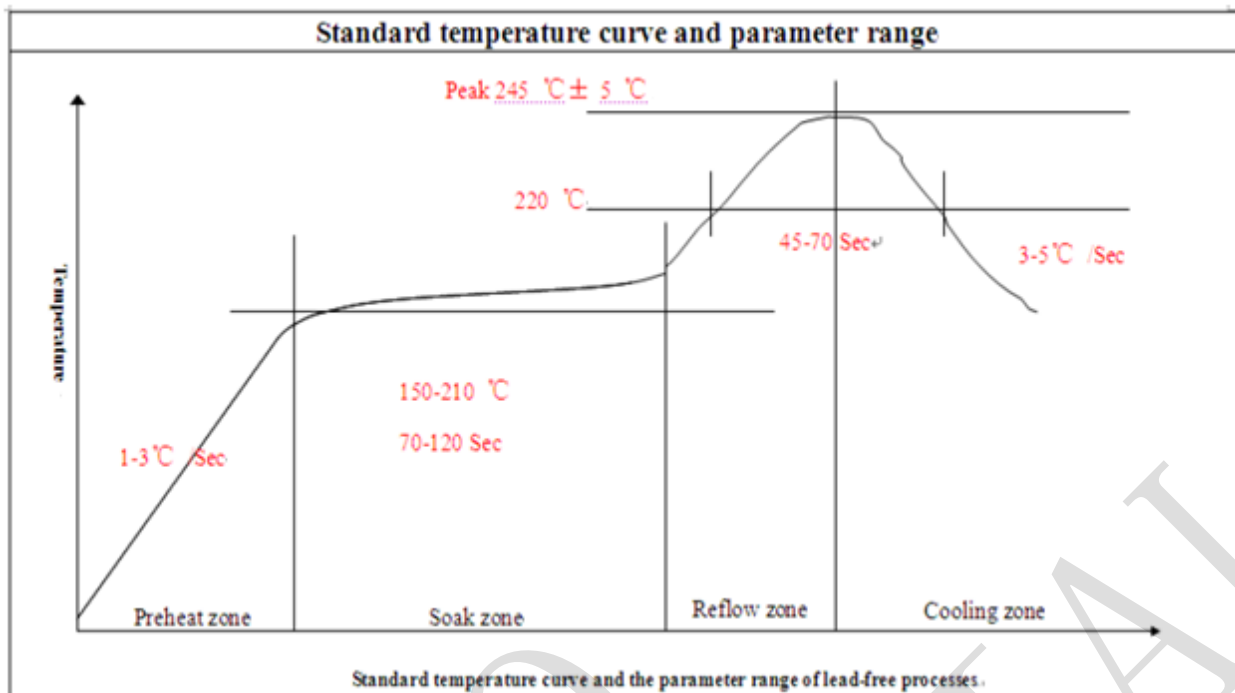

Figure 11 The Ramp-Soak-Spike reflow profile of N20

N20 is Moisture Sensitive Devices (MSD), appropriate MSD handling instruction and precautions are summarized in Chapter 6.3.

N20 modules are also Electrostatic Sensitive Devices (ESD), handling N20 modules without proper ESD protection may destroy or damage them permanently. Avoid ultrasonic exposure due to internal crystal and SAW components.

6.3 Moisture sensitivity

N20 module is moisture sensitive at MSL level 3, dry packed according to IPC/JEDEC specification J-STD-020C. The calculated shelf life for dry packed SMD packages is a minimum of 6 months from the bag seal date, when stored in a non condensing atmospheric environment of <40°C/90% RH.

Table 11 lists floor life for different MSL levels in the IPC/JDEC specification:

Table 11 Moisture Classification Level and Floor Life

Level	Floor Life(out of bag)at factory ambient $\leq +30^{\circ}\text{C}/60\%\text{RH}$ or as stated
1	Unlimited at $\leq +30^{\circ}\text{C}/85\% \text{RH}$
2	1 year
2a	4 weeks
3	168 hours
4	72 hours
5	48 hours
5a	24 hours
6	Mandatory bake before use. After bake, module must be reflowed within the time limit specified on the label.

Factory floor life is 1 week for MSL 3, N20 must be processed and soldered within the time. If this time is exceeded, the devices need to be pre-baked before the reflow solder process.

Both encapsulate and substrate materials absorb moisture. IPC/JEDEC specification J-STD-020 must be observed to prevent cracking and delamination associated with the "popcorn" effect during reflow soldering. The popcorn effect can be described as miniature explosions of evaporating moisture. Baking before processing is required in the following case:

- Floor life or environmental requirements after opening the seal have been exceeded, e.g. exposure to excessive seasonal humidity.

Refer to Section 4 of IPC/JEDEC J-STD-033 for recommended baking procedures.

6.4 ESD handling precautions

N20 module is Electrostatic Sensitive Devices (ESD). Observe precautions for handling! Failure to observe these precautions can result in severe damage to the GPS receiver!



GPS receivers are Electrostatic Sensitive Devices (ESD) and require special precautions when handling. Particular care must be exercised when handling patch antennas, due to the risk of electrostatic charges. In addition to standard ESD safety practices, the following measures should be taken into account whenever handling the receiver.

Unless there is a galvanic coupling between the local GND (i.e. the work Table) and the PCB GND, then the first point of contact when handling the PCB shall always be between the local GND and PCB GND. Before mounting an antenna patch, connect ground of the device

When handling the RF pin, do not come into contact with any charged capacitors and be careful when contacting materials that can develop charges (e.g. patch antenna ~10pF, coax cable ~50-80pF/m, soldering iron, ...) To prevent electrostatic discharge through the RF input, do not touch the mounted patch antenna.

When soldering RF connectors and patch antennas to the receiver's RF pin, the user must make sure to use an ESD safe soldering iron (tip).

6.5 Shipment

N20 is designed and packaged to be processed in an automatic assembly line, and it is now packaged tray and reel.

7. Reference Design

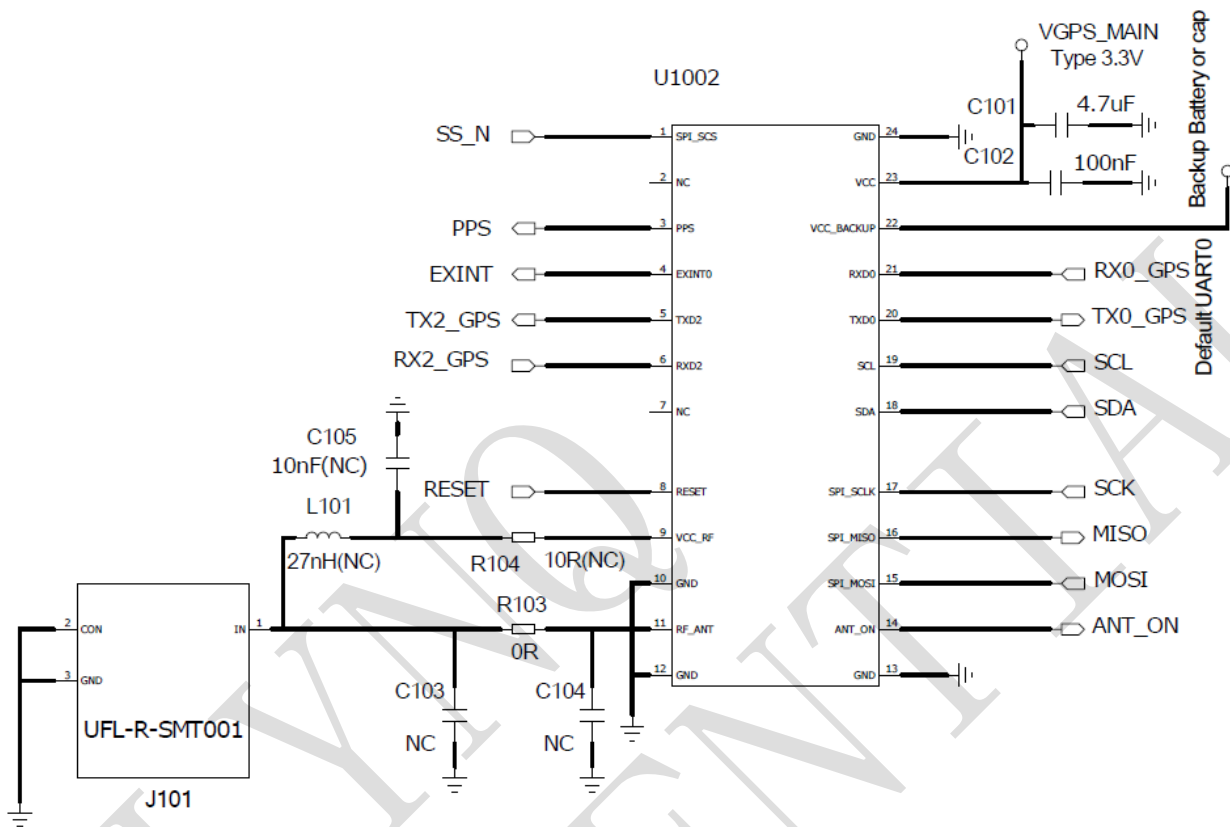

Figure 12 Application schematics

Appendix

A. Related Documents

Table 12 Related documents

SN	Document name	Remark
[1]	MT3333 Platform NMEA Message Specification	
[2]	EPO-II Format Protocol Customer	EPO-II Format and Protocol

B. Terms and Abbreviations

Abbreviation	Description
A-GPS	Assisted Global Positioning System
CMOS	Complementary Metal Oxide Semiconductor
CEP	Circular Error Probable
DGPS	Difference Global Positioning System
EEPROM	Electrically Erasable Programmable Read Only Memory
EPO	Extended Prediction Orbit
ESD	Electrostatic Sensitive Devices
EASY	Embedded Assist System
EGNOS	European Geostationary Navigation Overlay Service
GPS	Global Positioning System
GAGAN	The GPS Aided Geo Augmented Navigation
I/O	Input/Output
IC	Integrated Circuit
Inorm	Normal Current

Imax	Maximum Load Current
kbps	Kilo bits per second
MSL	moisture sensitive level
MSAS	Multi-Functional Satellite Augmentation System
NMEA	National Marine Electronics Association
PRN	Pseudo Random Noise Code
QZSS	Quasi-Zenith Satellites System
SBAS	Satellite Based Augmentation Systems
WAAS	Wide Area Augmentation System