

NO	DESCRIPTION	MATERIAL	Q'TY	FINISH	REMARK
1	BODY 1	BRASS	1	NICKEL	B-N0497-N
2	PIN	BRASS	1	GOLD	P-N0342-G
3	INSULATION	TEFLON	1	TEFLON	I-0247T
4	WASHER	PH.BRONZE	1	NICKEL	W-0014
5	GASKET	SI RUBBER	1	RUBBER	RU-0007
6	BODY 2	BRASS	1	NICKEL	B-N0032-N
7	BODY 3	BRASS	1	NICKEL	B-N0033-N
8	BODY 4	BRASS	1	NICKEL	B-N0498-N
9	WASHER	BRASS	1	NICKEL	W-0033-N
10	RING	BRASS	1	NICKEL	R-0007-N

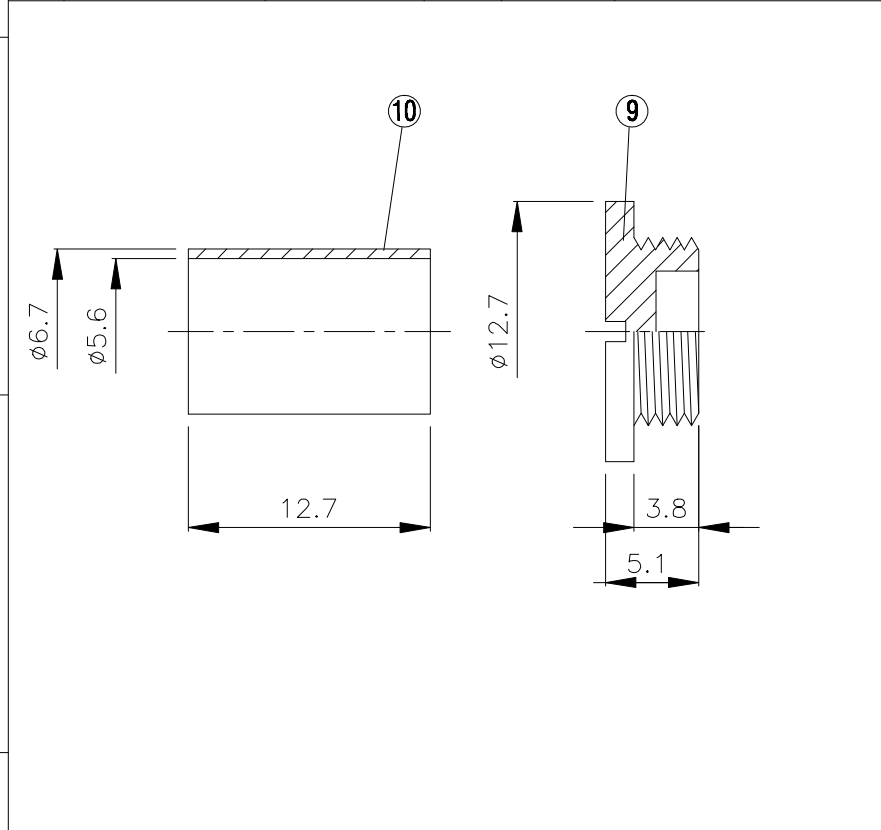
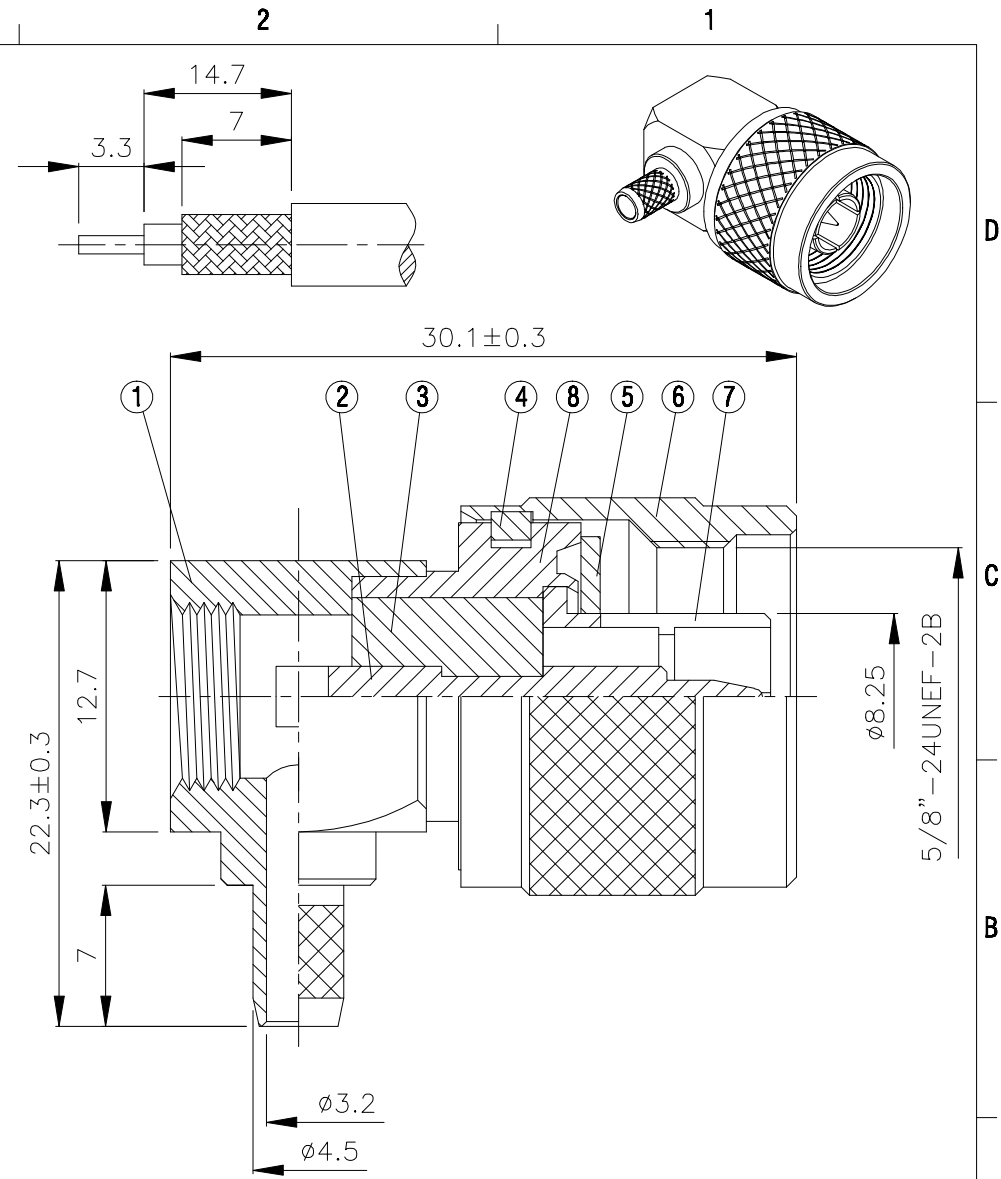

	HUS-TSAN GROUP CO., LTD.		DRAWN	MARY	DATE	DIMENSIONS ARE IN MILLIMETERS				REVISION	
	P.O.BOX 40-76.TAINAN.TAIWAN,R.O.C.		CHECKED	黃巧君	DATE					UNLESS OTHERWISE SPECIFIED TOLERANCE	
	TITLE N ANGLE MALE CRIMP FOR RG 58/U		Q.A.	蘇姿潔	DATE	0.5-5=±0.2	120-315=±1				
	PART NO. N-35F-TGN		APPROVAL	徐燦霖	DATE	5-30=±0.4	315-1000=±1.6				
	DRAWING NO. N 35F TGN		REVISION		DATE	30-120±0.6	1000-2000=±2.4				
					SCALE	4:1	SIZE	A			

4

3

2

1

D

D

C

C

B

B

A

A