



GlobalTop Technology Inc.

Mouse-DG

Data Sheet

Part Number: MiniGmousDG-PS2

Revision: V0D



Mouse-DG is a GNSS receiver. It provides a solution that is high position and speed accuracy performance, with high sensitivity and tracking capabilities in urban conditions.

This document is the exclusive property of GlobalTop Tech Inc. and should not be distributed, reproduced, into any other format without prior permission of GlobalTop Tech Inc. Specifications subject to change without prior notice.

Copyright © 2014 GlobalTop Technology Inc. All Rights Reserved.

No.16 Nan-ke 9th Rd, Science-Based Industrial Park, Tainan, 741, Taiwan, R.O.C.

Tel: +886-6-5051268 / Fax: +886-6-5053381 / Email: sales@gtop-tech.com / Web: www.gtop-tech.com

Version History

Title:	GlobalTop Mouse-DG Datasheet		
Subtitle:	GNSS Receiver		
Doc Type:	Datasheet		
Revision	Date	Author	Description
VOA	2014/8/10	Brian	First release
VOB	2014/8/15	Yingjie	Modify Spec.
VOC	2015/7/7	Max	Add application note 1pps description
V0D	2015/7/15	Archie Lin	NMEA output added; NMEA sentence output modified; power consumption value changed → min, typical, maximum

Table of Contents

1. Functional Description	4
1.1 Overview	4
1.2 Highlights and Features	4
2. Specifications	5
2.1 Mechanical Data	5
2.2 Mechanical Dimensions	5
2.3 Pin Assignment	6
2.4 Specification.....	7
3. Protocols	8
3.1 NMEA Output Sentences	8
3.2 MTK NMEA Command Protocols	15
3.3 Firmware Customization Services.....	15
4. Application Note	16
4.1 Connector type transformation	16
5. Contact Information	17

1. Functional Description

1.1 Overview

The GlobalTop Mouse-DG is a dual system GNSS receiver which acquires and tracks GPS/GLONASS systems concurrently to provide high sensitivity and tracking capabilities in various urban conditions which makes Mouse-DG a perfect solution for performance critical applications.

Mouse-DG supports up to 210 PRN channels with 99 search channels and 33 simultaneous tracking channels. With QZSS, SBAS (note1) ranging (WAAS, EGNOS, MSAS), QZSS and AGPS, Mouse-DG can provide even more accurate positioning.

Mouse-DG is capable of achieving the industry's highest level of sensitivity (-165dBm) and instant Time-to-First Fix (TTFF).

The integrated precise GNSS signal processing engine of Mouse-DG allows ultra-precise positioning under low receptive, high velocity conditions.

The ISSCC2011 awarded **12-Multi-Tone Active Interference Canceller** capable of removing 12 active noise sources enables customer to have more flexibility in system design.

1.2 Highlights and Features

- ◆ 33 tracking/ 99 acquisition-channel GPS/GLONASS receiver
- ◆ Supports QZSS, SBAS(WAAS, EGNOS, MSAS) ranging
- ◆ Ultra-High Sensitivity: -165dBm
- ◆ High Update Rate: up to 10Hz^(note1)
- ◆ 12 multi-tone active interference canceller^(Note2) [ISSCC 2011 Award -Section 26.5] (http://isscc.org/doc/2011/isscc2011.advanceprogrambooklet_abstracts.pdf)
- ◆ AGPS Support for Fast TTFF (EPO in flash™ Enable 7 days/14 days)
- ◆ EASY™^(note2): Self-Generated Orbit Prediction for instant positioning fix
- ◆ AlwaysLocate™^(note2) Intelligent Algorithm (Advance Power Periodic Mode) for power saving
- ◆ Logger function Embedded^(note2)
- ◆ Gtop Firmware Customization Services
- ◆ GPS+GLONASS Consumption current(@5V):
 - Acquisition: 36mA(min)/45mA(average) /53mA(max)
 - Tracking: 31mA(min)/ 40mA(average) /50mA(max)

Note 1: SBAS can only be enabled when update rate is equal or less than to 5Hz.

Note2: Some features need special firmware or command programmed by customer, please refer to "PMTK Command List" and "Firmware check list_C33".

2. Specifications

2.1 Mechanical Data

Item	Specification
Size	48 x 40 x 12.9 mm
Cable Length	2,000 +/-40 mm
Connector	Mini Din 6 pin (PS2)

2.2 Mechanical Dimensions

Dimension: (Unit: mm, Tolerance: +/- 0.2mm)

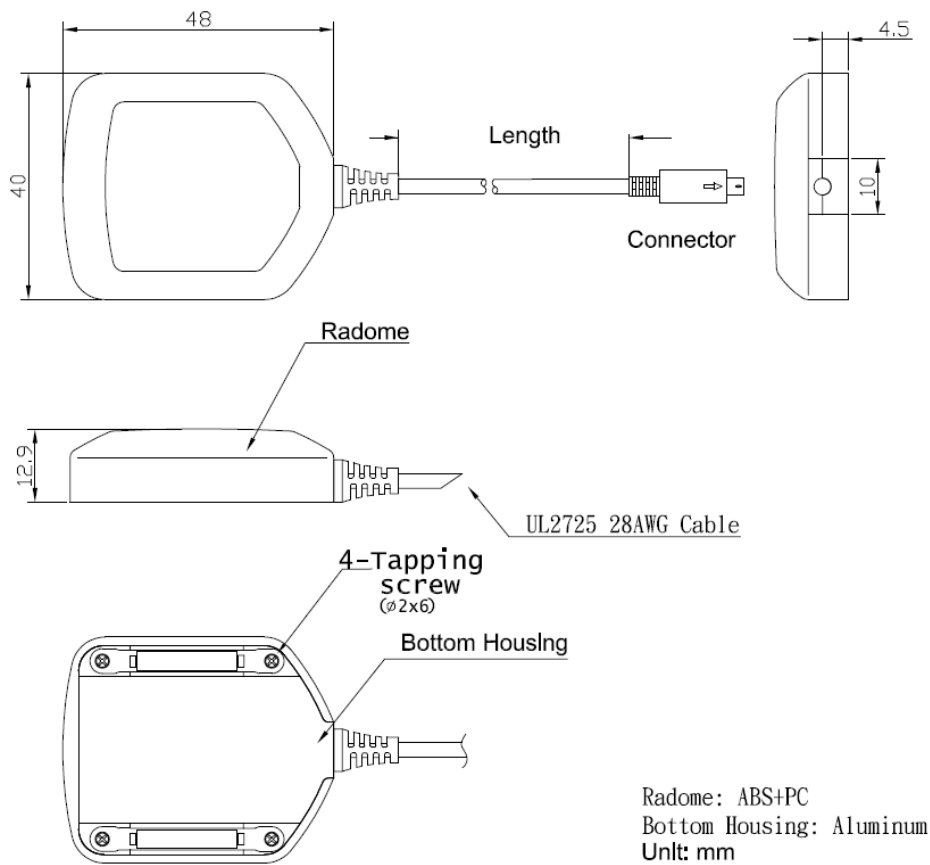

2.3 Pin Assignment

Pin	Name	I/O	Description
1	+5VDC		
2	GND	P	Ground
3	NC		
4	RX(RS232)	I	Serial Data Input for PMTK command
5	TX(RS232)	O	Serial Date Output
6	NC		

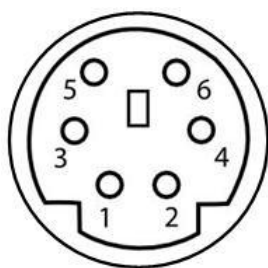

2.4 Specification

Description	
GNSS Solution	MTK MT3333
Frequency	GPS L1, 1575.42MHz GLONASS L1, 1598.0625~1605.375MHz
Sensitivity	Acquisition: -148dBm, cold start Reacquisition: -163dBm Hot start Tracking: -165dBm
TTF (No. of SVs>4, C/N>40dB, PDop<1.5)	Hot start: 1 second typical Warm start: 33 seconds typical Cold start: 35 seconds typical, 60 seconds Max
Position Accuracy	Without aid: 3.0m (50% CEP) DGPS(SBAS(WAAS,EGNOS,MSAS)): 2.5m (50% CEP)
Velocity Accuracy	Without aid: 0.1m/s DGPS(SBAS(WAAS,EGNOS,MSAS)):0.05m/s
Altitude	Maximum 50,000m (166,000 feet)
Velocity	Maximum 515m/s (1,000 knots)
Acceleration	Maximum 4G
Update Rate	1Hz (default), maximum 10Hz
Baud Rate	9600 bps (default)
DGPS	SBAS(default) [QZSS,WAAS, EGNOS, MSAS,GAGAN]
AGPS	Support
Power Supply	DC voltage: 5.0+/-10% V
Current Consumption @ 5.0V,1Hz Update Rate	GPS+GLONASS Acquisition: 36mA(min)/45mA(average) /53mA(max) Tracking: 31mA(min)/ 40mA(average) /50mA(max)
Enclosure rating	IP67
Working Temperature	-40 °C to +85 °C
Dimension	48 x 40 x 12.9 mm
Weight	70g

3. Protocols

3.1 NMEA Output Sentences

Table-1 lists each of the NMEA output sentences specifically developed and defined by MTK for use within MTK products

Table-1: NMEA Output Sentence	
Option	Description
GGA	Time, position and fix type data.
GSA	GNSS receiver operating mode, active satellites used in the position solution and DOP values.
GSV	The number of GNSS satellites in view satellite ID numbers, elevation, azimuth, and SNR values.
RMC	Time, date, position, course and speed data. Recommended Minimum Navigation Information.
VTG	Course and speed information relative to the ground.

Table-2 lists NMEA output sentences in GPS system and GLONASS system.

Table-2: NMEA Output Sentence for GPS and GNSS					
System	GGA	GSA	GSV	RMC	VTG
GPS	GPGGA	GPGSA	GPGSV	GPRMC	GPVTG
GNSS(GPS+Glonass)	GNGGA	GPGSA GLGSA	GPGSV GLGSV ^(Note1)	GNRMC	GNVTG
AXN 3.2 ^(Note2)	GPGGA	GNGSA	GPGSV GLGSV	GPRMC or GNRMC	GPVTG

(Note1): In Talker ID, "GP" represents GPS satellite; "GL" represents GLONASS satellite; GN represents "GPS +GLONASS" satellite

(Note2): AXN 3.2 is used in the old version and will no longer be supported.

GGA—Fixed Data. Time, Position and fix related data

Table-3 contains the values for the following example:

\$GNGGA,064951.000,2307.1256,N,12016.4438,E,1,8,0.95,39.9,M,17.8,M,,*65

Table-3: GGA Data Format			
Name	Example	Units	Description
Message ID	\$GNGGA		GGA protocol header
UTC Time	064951.000		hhmmss.sss
Latitude	2307.1256		ddmm.mmmm
N/S Indicator	N		N=north or S=south
Longitude	12016.4438		dddmm.mmmm
E/W Indicator	E		E=east or W=west
Position Fix Indicator	1		See Table-4
Satellites Used	8		Range 0 to 14
HDOP	0.95		Horizontal Dilution of Precision
MSL Altitude	39.9	meters	Antenna Altitude above/below mean-sea-level
Units	M	meters	Units of antenna altitude
Geoidal Separation	17.8	meters	
Units	M	meters	Units of geoids separation
Age of Diff. Corr.		second	Null fields when DGPS is not used
Checksum	*65		
<CR> <LF>			End of message termination

Table-4: Position Fix Indicator	
Value	Description
0	Fix not available
1	GPS fix
2	Differential GPS fix

Note: when inputting the commend \$PMTK353,0,1,0,0,0*2A, \$GNGGA will change to \$GLGGA(For GLONASS)

When inputting the commend \$PMTK353,1,0,0,0,0*2A : \$GNGGA will change to \$GPGGA(For GPS)

GSA—GNSS DOP and Active Satellites

Table-5 contains the values for the following example:

GPS satellite system →

\$GPGSA,A,3,29,21,26,15,18,09,06,10,,,,,2.32,0.95,2.11*00

GPS+GLONASS satellite system →

\$GPGSA,A,3,08,28,20,04,32,17,11,,,,,1.00,0.63,0.77*1B (GPS satellite)

\$GLGSA,A,3,77,76,86,78,65,88,87,71,72,,,,,1.00,0.63,0.77*17 (GLONASS satellite)

Table-5: GSA Data Format			
Name	Example	Units	Description
Message ID	\$GPGSA, or \$GLGSA		GSA protocol header
Mode 1	A		See Table-6
Mode 2	3		See Table-7
Satellite Used ¹	29		SV on Channel 1
Satellite Used ¹	21		SV on Channel 2
....
Satellite Used ¹			SV on Channel 12
PDOP	2.32		Position Dilution of Precision
HDOP	0.95		Horizontal Dilution of Precision
VDOP	2.11		Vertical Dilution of Precision
Checksum	*00		
<CR> <LF>			End of message termination

Note: GPS SV No. : #1~#32
 Glonass SV No.: #65~#96

Table-6: Mode 1	
Value	Description
M	Manual—forced to operate in 2D or 3D mode
A	2D Automatic—allowed to automatically switch 2D/3D

Table-7: Mode 2	
Value	Description
1	Fix not available
2	2D (< 4 SVs used)
3	3D (≥ 4 SVs used)

GSV— Satellites in View, includes GPS (GPGSV) and GLONASS(GLGSV)

Table-8 contains the values for the following example :

\$GPGSV,4,1,14,28,75,321,44,42,54,137,39,20,53,080,44,17,40,330,44*77

\$GPGSV,4,2,14,04,33,253,43,32,28,055,41,08,26,212,40,11,14,055,33*7F

\$GPGSV,4,3,14,10,12,198,,07,06,179,38,23,04,125,44,27,02,314,*7E

\$GPGSV,4,4,14,193,,,42,01,,,36*45

Table-8: GPGSV Data Format			
Name	Example	Units	Description
Message ID	\$GPGSV		GSV protocol header
Number of Messages	4		Range 1 to 4 <i>(Depending on the number of satellites tracked, multiple messages of GSV data may be required.)</i> ^(Note)
Message Number1	1		Range 1 to 4
Satellites in View	14		
Satellite ID	28		Channel 1 (Range 1 to 32)
Elevation	75	degrees	Channel 1 (Maximum 90)
Azimuth	321	degrees	Channel 1 (True, Range 0 to 359)
SNR (C/No)	44	dB-Hz	Range 0 to 99, (null when not tracking)
....
Satellite ID	17		Channel 4 (Range 1 to 32)
Elevation	40	degrees	Channel 4 (Maximum 90)
Azimuth	330	degrees	Channel 4 (True, Range 0 to 359)
SNR (C/No)	44	dB-Hz	Range 0 to 99, (null when not tracking)
Checksum	*7D		
<CR> <LF>			End of message termination

(Note): The maximum every GSV sentence only include information for 4 SVs.

Table-9 contains the values for the following example :

\$GLGSV,3,1,09,72,45,084,40,77,39,246,44,87,36,014,44,65,33,157,36*62

\$GLGSV,3,2,09,78,26,306,41,88,23,315,42,76,15,192,38,86,13,067,38*64

\$GLGSV,3,3,09,71,12,035,38*54

Table-9: GLGSV Data Format			
Name	Example	Units	Description
Message ID	\$GLGSV		GSV protocol header
Number of Messages	4		Range 1 to 4 <i>(Depending on the number of satellites tracked, multiple messages of GSV data may be required.)</i> ^(Note)
Message Number1	1		Range 1 to 4
Satellites in View	09		
Satellite ID	78		Channel 1 (Range 1 to 32)
Elevation	26	degrees	Channel 1 (Maximum 90)
Azimuth	306	degrees	Channel 1 (True, Range 0 to 359)
SNR (C/No)	41	dB-Hz	Range 0 to 99, (null when not tracking)
....
Satellite ID	88		Channel 4 (Range 1 to 32)
Elevation	23	degrees	Channel 4 (Maximum 90)
Azimuth	315	degrees	Channel 4 (True, Range 0 to 359)
SNR (C/No)	42	dB-Hz	Range 0 to 99, (null when not tracking)
Checksum	*7D		
<CR> <LF>			End of message termination

(Note): One GSV sentence can only receive up to 4 SVs

RMC—Recommended Minimum Navigation Information, includes GPS(GPRMC) or GNSS(GNRMC)

Table-10 contains the values for the following example :

\$GNRMC,064951.000,A,2307.1256,N,12016.4438,E,0.03,165.48,260406,3.05,W,A*2C

Table-10: RMC Data Format			
Name	Example	Units	Description
Message ID	\$GNRMC		RMC protocol header
UTC Time	064951.000		hhmmss.sss
Status	A		A=data valid or V=data not valid
Latitude	2307.1256		ddmm.mmmm
N/S Indicator	N		N=north or S=south
Longitude	12016.4438		dddmm.mmmm
E/W Indicator	E		E=east or W=west
Speed over Ground	0.03	knots	
Course over Ground	165.48	degrees	True
Date	260406		ddmmyy
Magnetic Variation	3.05, W	degrees	E=east or W=west <i>(By Customization Service)</i>
Mode	A		A= Autonomous mode D= Differential mode E= Estimated mode
Checksum	*2C		
<CR> <LF>			End of message termination

Note: when inputting the commend \$PMTK353,0,1,0,0,0*2A , \$GNRMC will change to \$GLRMC (GLONASS only).

When inputting the commend \$PMTK353,1,0,0,0,0*2A : \$GNRMC will change to \$GPRMC(For GPS).

VTG—Course and speed information relative to the ground

Table-11 contains the values for the following example:

\$GNVTG,165.48,T,,M,0.03,N,0.06,K,A*37

Table-11: VTG Data Format			
Name	Example	Units	Description
Message ID	\$GNVTG		VTG protocol header
Course	165.48	degrees	Measured heading
Reference	T		True
Course		degrees	Measured heading
Reference	M		Magnetic <i>(By Customization Service)</i>
Speed	0.03	knots	Measured horizontal speed
Units	N		Knots
Speed	0.06	km/hr	Measured horizontal speed
Units	K		Kilometers per hour
Mode	A		A= Autonomous mode D= Differential mode E= Estimated mode
Checksum	*06		
<CR> <LF>			End of message termination

Note: when inputting the commend \$PMTK353,0,1,0,0,0*2A , \$GNVTG will change to \$GLVTG(For GLONASS)

When inputting the commend \$PMTK353,1,0,0,0,0*2A : \$GNVTG will change to \$GPVTG (For GPS)

3.2 MTK NMEA Command Protocols

Packet Type:

103 PMTK_CMD_COLD_START

Packet Meaning:

Cold Start : Don't use Time, Position, Almanacs and Ephemeris data at re-start.

Example:

\$PMTK103*30<CR><LF>

3.3 Firmware Customization Services

GlobalTop also offers flexible, value-adding GPS firmware customization services that maximize the overall system efficiencies and power consumptions. To find out the latest features like Binary Mode, One-Sentence Output, Geo-fencing and Last Position Retention, please visit our website at www.gtop-tech.com.

Note that not all firmware customization services listed below are supported for all products.

Please contact GlobalTop sales representatives or technical support for more details.



The graphic features the GlobalTop logo at the top left. The title "GlobalTop Firmware Customization Services" is centered at the top. Below the title, two columns of text list various services, flanking a central image of two GPS modules (one white, one orange) inside a circular frame. The left column lists "Basic functions" and the right column lists "Advanced functions".

<p>Basic functions:</p> <ul style="list-style-type: none"> Distance calculation Binary mode One sentence Geo-fencing Navigation mode Last position retention 		<p>Advanced functions:</p> <ul style="list-style-type: none"> 10Hz Update Rate Extended Altitude AGPS PPS Mode Power Saving Mode Locus
---	--	---

4. Application Note

4.1 Connector type transformation

MiniGmouseDG-PS2 connect to PC / RS232 ;

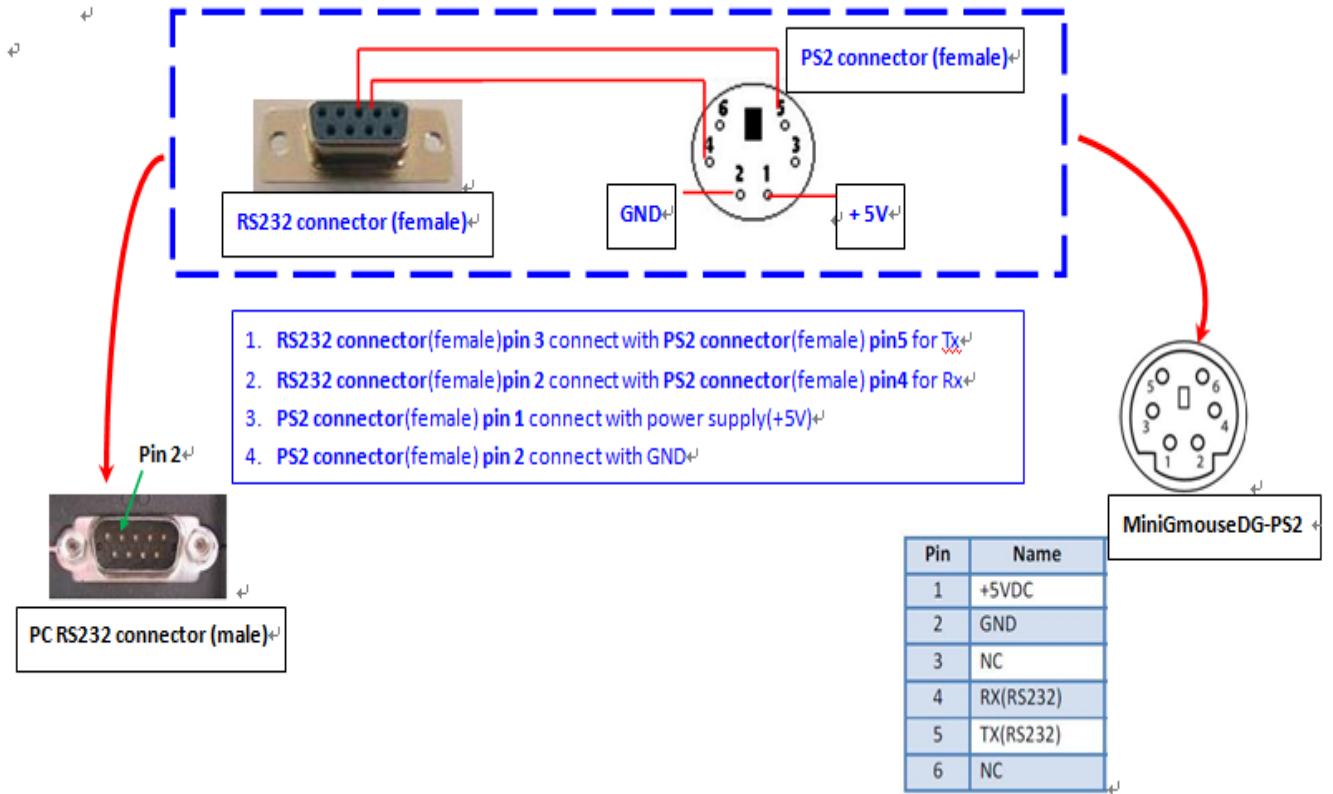

5. Contact Information

GlobalTop Technology Inc.

Address: No.16 Nan-ke 9rd Road Science-based Industrial Park, Tainan 741, Taiwan

Tel: +886-6-5051268

Fax: +886-6-5053381

Website: www.gtop-tech.com

Email: sales@gtop-tech.com