

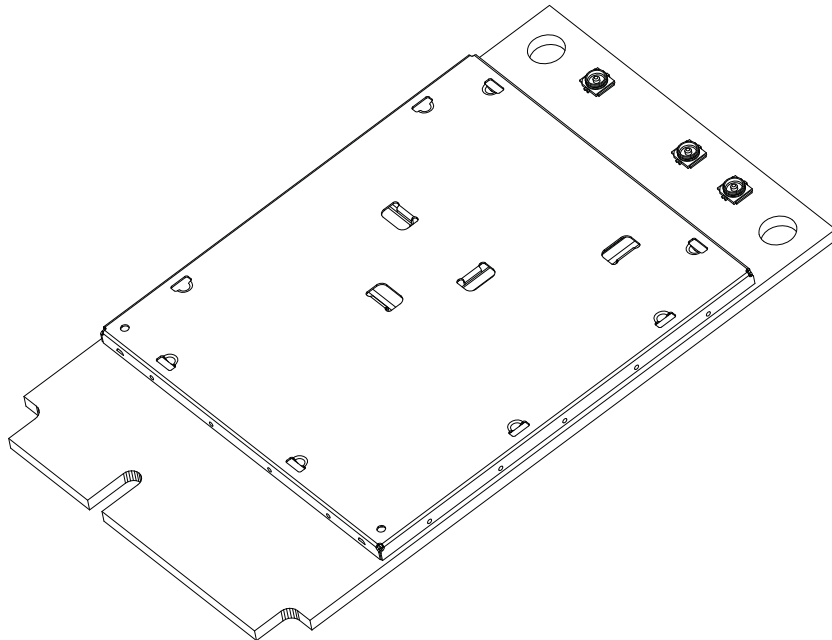

Product Technical Specification & Customer Design Guidelines

AirPrime MC7455



SIERRA
WIRELESS®

4116238

Rev 6

Proprietary and Confidential
Contents subject to change

Important Notice

Due to the nature of wireless communications, transmission and reception of data can never be guaranteed. Data may be delayed, corrupted (i.e., have errors) or be totally lost. Although significant delays or losses of data are rare when wireless devices such as the Sierra Wireless modem are used in a normal manner with a well-constructed network, the Sierra Wireless modem should not be used in situations where failure to transmit or receive data could result in damage of any kind to the user or any other party, including but not limited to personal injury, death, or loss of property. Sierra Wireless accepts no responsibility for damages of any kind resulting from delays or errors in data transmitted or received using the Sierra Wireless modem, or for failure of the Sierra Wireless modem to transmit or receive such data.

Safety and Hazards

Do not operate the Sierra Wireless modem in areas where blasting is in progress, where explosive atmospheres may be present, near medical equipment, near life support equipment, or any equipment which may be susceptible to any form of radio interference. In such areas, the Sierra Wireless modem **MUST BE POWERED OFF**. The Sierra Wireless modem can transmit signals that could interfere with this equipment.

Do not operate the Sierra Wireless modem in any aircraft, whether the aircraft is on the ground or in flight. In aircraft, the Sierra Wireless modem **MUST BE POWERED OFF**. When operating, the Sierra Wireless modem can transmit signals that could interfere with various onboard systems.

Note: Some airlines may permit the use of cellular phones while the aircraft is on the ground and the door is open. Sierra Wireless modems may be used at this time.

The driver or operator of any vehicle should not operate the Sierra Wireless modem while in control of a vehicle. Doing so will detract from the driver or operator's control and operation of that vehicle. In some states and provinces, operating such communications devices while in control of a vehicle is an offence.

Limitation of Liability

The information in this manual is subject to change without notice and does not represent a commitment on the part of Sierra Wireless. SIERRA WIRELESS AND ITS AFFILIATES SPECIFICALLY DISCLAIM LIABILITY FOR ANY AND ALL DIRECT, INDIRECT, SPECIAL, GENERAL, INCIDENTAL, CONSEQUENTIAL, PUNITIVE OR EXEMPLARY DAMAGES INCLUDING, BUT NOT LIMITED TO, LOSS OF PROFITS OR REVENUE OR ANTICIPATED PROFITS OR REVENUE ARISING OUT OF THE USE OR INABILITY TO USE ANY SIERRA WIRELESS PRODUCT, EVEN IF SIERRA WIRELESS AND/OR ITS AFFILIATES HAS BEEN ADVISED OF THE POSSIBILITY OF SUCH DAMAGES OR THEY ARE FORESEEABLE OR FOR CLAIMS BY ANY THIRD PARTY.

Notwithstanding the foregoing, in no event shall Sierra Wireless and/or its affiliates aggregate liability arising under or in connection with the Sierra Wireless product, regardless of the number of events, occurrences, or claims giving rise to liability, be in excess of the price paid by the purchaser for the Sierra Wireless product.

Patents

This product may contain technology developed by or for Sierra Wireless Inc.

This product includes technology licensed from QUALCOMM®.

This product is manufactured or sold by Sierra Wireless Inc. or its affiliates under one or more patents licensed from InterDigital Group and MMP Portfolio Licensing.

Copyright

©2016 Sierra Wireless. All rights reserved.

Trademarks

Sierra Wireless®, AirPrime®, Skylight™, and the Sierra Wireless logo are trademarks of Sierra Wireless.

Watcher™ is a registered trademark of NETGEAR, Inc., used under license.

Windows® is a registered trademark of Microsoft Corporation.

QUALCOMM® is a registered trademark of QUALCOMM Incorporated. Used under license.

Other trademarks are the property of their respective owners.

Contact Information

Sales Desk:	Phone:	1-604-232-1488
	Hours:	8:00 AM to 5:00 PM Pacific Time
	E-mail:	sales@sierrawireless.com
Post:	Sierra Wireless 13811 Wireless Way Richmond, BC Canada V6V 3A4	
Fax:	1-604-231-1109	
Web:	www.sierrawireless.com	

Consult our website for up-to-date product descriptions, documentation, application notes, [firmware](#) upgrades, troubleshooting tips, and press releases:

www.sierrawireless.com

Revision History

Revision number	Release date	Changes
1	October 2014	Initial release.
2	October 2014	Updated system block (Figure 3-1), LTE Rx sensitivity (Table 4-3), UMTS Rx sensitivity (Table 4-4), Tx tolerances (Table 4-5)

Revision number	Release date	Changes
3	February 2015	<p>Updated Table 4-3 on page 43 (LTE sensitivity) Updated Table 4-4 on page 44 (UMTS sensitivity) Updated Table 4-5 on page 44 (Tx power) Updated typo in table 3-4 (USIM2_GND) Updated Table 4-6 on page 44 (# of satellites) Updated description/functionality of W_DISABLE_N</p>
4	September 2015	<p>Updated Carrier Aggregation combinations (Table 1-2 on page 16) Corrected SIM signal descriptions/notes (Table 3-4 on page 31) Added LTE B30 Removed LTE B17 Removed LTE CA B30+B29 Updated Table 4-3 on page 43 (LTE sensitivity) Updated Table 4-4 on page 44 (UMTS sensitivity) Updated Table 4-5 on page 44 (Tx power)</p>
5	November 2015	<p>Updated Figure 3-2 on page 25 (RF block diagram) Updated system reset time (SYSTEM_RESET_N—Reset Input on page 36) Updated module weight (Table 7-1 on page 57) Added signal strength for acquisition time values (Table 4-6 on page 44) Updated power-on/off timing values Updated minimum Vcc value to 3.135V Updated USB signal voltages (Table 3-1 on page 26) Minor update to wording for heat sink location in Thermal Considerations on page 60</p>
6	January 2016	<p>Updated temperature description/details to reflect device performance, including:</p> <ul style="list-style-type: none"> • Physical features on page 16—Clarified temperature range as ‘ambient’. • Physical features on page 16 and Module Integration Testing on page 61—Added AT!PCTEMP to note and adjusted suggested ‘best performance’ max temperature. • Table 5-5 on page 50—Added explanatory note for TEMP_HI_WARN state. • Table 7-1 on page 57—Clarified temperature ranges as ‘ambient’. <p>Adjusted GNSS tracking sensitivity specification to -160 dBm from -161 dBm to reflect tolerance range of measurement (Table 4-6 on page 44).</p>

»» Contents

Introduction	15
Supported RF Bands	15
Physical features	16
Application Interface Features	16
Modem Features	17
LTE Features	17
Short Message Service (SMS) Features	18
Position Location (GNSS)	18
Supporting Documents	18
Accessories	19
Required Connectors	19
Ordering Information	19
Integration Requirements	19
Standards Compliance	21
Electrical Specifications	23
Host Interface Pin Assignments	25
Power Supply	30
USB Interface	30
USB Throughput Performance	31
User-developed Drivers	31
SIM Interface	31
SIM Implementation	33
Control Interface (Signals)	34
WAKE_N — Wake Host	34
W_DISABLE_N — Wireless Disable	35
WAN_LED_N—LED Output	35
SYSTEM_RESET_N—Reset Input	36

- Antenna Control 36
- RF Specifications 37**
 - RF Connections 37
 - Shielding 37
 - Antenna and Cabling 38
 - Ground Connection 39
 - Interference and Sensitivity 39
 - Interference From Other Wireless Devices 39
 - Host-generated RF Interference 39
 - Device-generated RF Interference 40
 - Methods to Mitigate Decreased Rx Performance 40
 - Radiated Spurious Emissions (RSE) 40
 - Radiated Sensitivity Measurement 40
 - Sierra Wireless' Sensitivity Testing and Desensitization Investigation . . 41
 - Sensitivity vs. Frequency 41
 - Supported Frequencies 41
 - Conducted Rx Sensitivity / Tx Power 43
 - GNSS Specifications 44
- Power 47**
 - Power Consumption 47
 - Module Power States 49
 - Power State Transitions 50
 - Power Interface 51
 - Power Ramp-up 51
 - Power-On/Off Timing 51
 - Power supply Noise 52
 - SED (Smart Error Detection) 52
 - Tx Power Control 53
- Software Interface 55**
 - Support Tools 55

USB Interface 55

Mechanical and Environmental Specifications57

 Device Views 58

 Labeling 59

 Electrostatic Discharge (ESD)59

 Thermal Considerations 60

Regulatory Compliance and Industry Certifications63

 Important Notice 63

 Safety and hazards 64

 Important compliance information for North American users 64

Audio Support67

 PCM/I2S Audio Interface68

Antenna Specification71

 Recommended Main/Diversity Antenna Specifications 71

 Recommended GNSS Antenna Specifications 73

 Antenna Tests 74

Design Checklist75

Testing77

 AT Command Entry Timing Requirement 77

 Acceptance Testing 77

 Acceptance Test Requirements78

 Acceptance Test Procedure78

 Certification Testing 78

 Production Testing 79

Functional Production Test	79
Production Test Procedure	80
UMTS (WCDMA) RF Transmission Path Test	82
UMTS (WCDMA) RF Receive Path Test	84
LTE RF Receive Path Test	86
GNSS RF Receive Path Test	88
Quality Assurance Testing.	88
Suggested Testing Equipment.	89
Testing Assistance Provided by Sierra Wireless	89
IOT/Operator Testing.	89
Extended AT Commands for Testing.	90
Packaging	93
References	95
Sierra Wireless Documents	95
Command Documents	95
Other Sierra Documents	95
Industry/Other Documents	95
Acronyms	97
Index.	103

List of Tables

Table 1-1: Supported RF Bands	15
Table 1-2: Carrier Aggregation Combinations	16
Table 1-3: Required Host-module Connectors	19
Table 2-1: Standards Compliance	21
Table 3-1: Connector Pin Assignments	26
Table 3-2: Power and Ground Specifications	30
Table 3-3: USB Interfaces	30
Table 3-4: SIM Interface Signals	31
Table 3-5: Module Control Signals	34
Table 3-6: W_DISABLE_N Usage	35
Table 3-7: Antenna Control Signals	36
Table 4-1: LTE Frequency Bands	41
Table 4-2: WCDMA Frequency Bands	42
Table 4-3: Conducted Rx (Receive) Sensitivity—LTE Bands	43
Table 4-4: Conducted Rx (Receive) Sensitivity—UMTS Bands	44
Table 4-5: Conducted Tx (Transmit) Power Tolerances	44
Table 4-6: GNSS Specifications	44
Table 5-1: Averaged Standby DC Power Consumption	47
Table 5-2: Averaged Call Mode DC Power Consumption	48
Table 5-3: Miscellaneous DC Power Consumption	48
Table 5-4: Module Power States	49
Table 5-5: Power State Transitions (including voltage/temperature trigger levels). 50	
Table 5-6: Power-On/Off Timing Parameters (Double Enumeration)	52
Table 5-7: Power-on/off timing parameters (single enumeration)	52
Table 5-8: Dynamic Power Control of SAR Backoff State	53
Table 7-1: Mechanical and Environmental Specifications	57
Table 8-1: Antenna Gain Specifications	65

Table 8-2: Collocated Radio Transmitter Specifications	65
Table A-1: Connector Pin Assignments	67
Table A-2: PCM/I2S Interface Signals	68
Table A-3: PCM Timing.	69
Table A-4: Master Transmitter With Data Rate = 1.536 MHz ($\pm 10\%$)	70
Table B-1: Antenna Requirements	71
Table B-2: GNSS Antenna Requirements.	73
Table C-1: Hardware Integration Design Considerations	75
Table D-1: Test Settings—UMTS Transmission Path	82
Table D-2: Test Settings—UMTS Receive Path.	84
Table D-3: Test Settings—LTE Receive Path	86
Table D-4: Extended AT Commands	90
Table G-1: Acronyms and Definitions	97

»» | List of Figures

Figure 3-1: System Block Diagram	24
Figure 3-2: Expanded RF Block Diagram	25
Figure 3-3: SIM Application Interface (applies to both SIM interfaces)	32
Figure 3-4: SIM Card Contacts (contact view).	32
Figure 3-5: Recommended WAKE_N Connection.	34
Figure 3-6: Example LED	35
Figure 4-1: Module Connectors	37
Figure 5-1: Voltage/Temperature Monitoring State Machines	51
Figure 5-2: Signal Timing (W_DISABLE_N, and USB Enumeration)	51
Figure 7-1: Top View	58
Figure 7-2: Dimensioned View.	58
Figure 7-3: Sample Unit Label	59
Figure 7-4: Shield locations (Top view)	60
Figure A-1: Timing—PCM_SYNC	68
Figure A-2: Timing—PCM codec to module	69
Figure A-3: Timing—Module to PCM Codec.	69
Figure A-4: I2S Transmitter Timing	70
Figure 5-1: Device Placement in Module Tray.	93
Figure 5-2: Shipping Package	93

1: Introduction

The Sierra Wireless MC7455 PCI Express Mini Card is a compact, lightweight, wireless LTE- and UMTS-based modem that provides LTE, UMTS, and GNSS connectivity for M2M applications, notebook, ultrabook and tablet computers over several radio frequency bands.

Supported RF Bands

The modem, based on Qualcomm's MDM9230 baseband processor, supports data operation on LTE and UMTS networks over the bands described in Table 1-1, with LTE carrier aggregation (CA) as described in Table 1-2.

Table 1-1: Supported RF Bands

Technology	Bands															Data Rates/Notes
	1	2	3	4	5	7	8	12	13	20	25	26	29	30	41	
LTE	F	F	F	F	F	F	F	F	F	F	F	F	F	F	T	Data rates: <ul style="list-style-type: none"> Downlink (Cat 6): FDD: 300 Mbps TDD: 222 Mbps Uplink (Cat 6): FDD: 50 Mbps TDD: 26 Mbps Notes: <ul style="list-style-type: none"> Downlink MIMO support (2x2; 4x2) F=FDD; T= TDD
DC-HSPA+ HSPA+ HSPA UMTS	Y	Y	Y	Y	Y		Y							N/A	Data rates: <ul style="list-style-type: none"> Downlink (Cat 24): Up to 42 Mbps Uplink (Cat 6): Up to 5.76 Mbps Notes: <ul style="list-style-type: none"> Diversity support 	
GNSS	<ul style="list-style-type: none"> GPS: 1575.42 MHz GLONASS: 1602 MHz BeiDou: 1561.098 MHz Galileo¹: 1575.42 MHz 															

1. Future firmware upgrade

Table 1-2: Carrier Aggregation Combinations

1 + 8
2 + 2/5/12/13/29
3 + 7/20
4 + 4/5/12/13/29
5 + 2/4/30
7 + 3/7/20
8 + 1
12 + 2/4/30
13 + 2/4
20 + 3/7
30 + 5/12
41 + 41

Physical features

- Small form factor—conforms to type F2 as specified in *PCI Express Mini Card Electromechanical Specification Revision 1.2*.
- Ambient operating temperature range:
 - Class A (3GPP compliant): -30°C to +70°C
 - Class B (operational, non-3GPP compliant): -40°C to +85°C (reduced operating parameters required)

Important: *The internal module temperature (reported by AT!PCTEMP) must be kept below 90°C. For best performance, the internal module temperature should be kept below 80°C. Proper mounting, heat sinks, and active cooling may be required, depending on the integrated application.*

Application Interface Features

- USB interface (QMI) for Windows 7 and legacy Windows operating systems
- MBIM for Windows 8.1 and Windows 10
- AT command interface ([1] *AT Command Set for User Equipment (UE) (Release 6) (Doc# 3GPP TS 27.007)*, plus proprietary extended AT commands in [2] *AirPrime EM74xx/MC74xx AT Command Reference (Doc# 4117727)*)
- Software Development Kits (SDK), including API (Application Program Interface) functions:
 - Windows 7, Windows 8.1, Windows 10
 - Linux

Note: OMA DM and FOTA support is operator-dependent.

- Support for active antenna control via dedicated antenna control signals (ANT_CTRL0:2)
- Dynamic power reduction support via software and dedicated signal (DPR)
- OMA DM (Open Mobile Alliance Device Management)
- FOTA (Firmware Over The Air)

Modem Features

- LTE / DC-HSPA+ / HSPA+ / HSPA / UMTS (WCDMA) operation
- Multiple (up to 16) cellular packet data profiles
- Traditional modem COM port support for AT commands
- USB suspend / resume
- Sleep mode for minimum idle power draw
- SIM application tool kit with proactive SIM commands
- Enhanced Operator Name String (EONS)
- Mobile-originated PDP context activation / deactivation
- Support QoS profile
 - Release 99 QoS negotiation—Background, Interactive, and Streaming
 - Release 97—Precedence Class, Reliability Class, Delay Class, Peak Throughput, Mean Throughput
- Static and Dynamic IP address. The network may assign a fixed IP address or dynamically assign one using DHCP (Dynamic Host Configuration Protocol).
- PAP and CHAP support
- PDP context type (IPv4, IPv6, or IPv4v6). IP Packet Data Protocol context supports dual IPv4v6.
- RFC1144 TCP/IP header compression

LTE Features

- Carrier aggregation:
 - DL LTE-FDD
 - 20 MHz intraband non-contiguous
 - 40 MHz interband
 - DL LTE-TDD
 - 40 MHz intraband contiguous and non-contiguous
 - 40 MHz interband
- CSG support (LTE Femto)
- LTE Advanced receivers (NLIC, eICIC, feICIC)
- Basic cell selection and system acquisition
 - PSS/SSS/MIB decode
 - SIB1–SIB16 decoding
- NAS/AS security procedures
 - Snow 3G/AES/ZUC security

- [CQI](#)/RI/PMI reporting
- Paging procedures
 - Paging in Idle and Connected mode
- Dedicated bearer
 - Network-initiated dedicated bearer
 - [UE](#)-initiated dedicated bearer
- Multiple PDN connections (IPv4 and IPv6 combinations), subject to operating system support.
- Connected mode intra-LTE mobility
- Idle mode intra-LTE mobility
- iRAT between LTE/3G for idle and connection release with redirection
- Detach procedure
 - Network-initiated detach with reattach required
 - Network-initiated detach followed by connection release

Short Message Service (SMS) Features

- Mobile-originated and mobile-terminated SMS over [IMS](#) for LTE
- Mobile-originated and mobile-terminated SMS over SGs for LTE

Position Location (GNSS)

- Customizable tracking session
- Automatic tracking session on startup
- Concurrent standalone GPS, GLONASS, and BeiDou
- Concurrent standalone Galileo (future firmware upgrade)
- Assisted GPS ([A-GPS](#)) SUPL1.0
- Assisted GPS/GLONASS SUPL2.0
- gpsOneXTRA 3.0 with GPS + GLONASS + BeiDou support
- GPS/GLONASS on dedicated connector or diversity connector
- BeiDou on dedicated connector, or on diversity connector with reduced performance
- Galileo on dedicated connector or diversity connector (future firmware upgrade)

Supporting Documents

Several additional documents describe Mini Card design, usage, integration, and other features. See [References on page 95](#).

Accessories

The Universal Development Kit (UDK) is a hardware development platform for AirPrime MC-series modules. It contains hardware components for evaluating and developing with the module, including:

- Development board
- Cables
- Antennas (Additional antennas may be required to support all bands.)
- Initial allotment of support hours
- Other accessories

For instructions on setting up the UDK, see [3] *PCI Express Mini Card Dev Kit Quick Start Guide (Doc# 2130705)*.

For over-the-air LTE testing, ensure that suitable antennas are used. (Two antennas are required for this testing.)

Required Connectors

Table 1-3 describes the connectors used to integrate AirPrime MC-series modules into your host device.

Table 1-3: Required Host-module Connectors¹

Connector type	Description
RF cables	<ul style="list-style-type: none"> • Mate with Hirose U.FL connectors (model U.FL #CL331-0471-0-10) • Three connector jacks
EDGE (52-pin)	<ul style="list-style-type: none"> • Industry-standard mating connector • Some manufacturers include Tyco, Foxconn, Molex • Example: UDK board uses Molex 67910-0001
SIM	<ul style="list-style-type: none"> • Industry-standard connector. Type depends on how host device exposes the SIM socket • Example: UDK board uses ITT CCM03-3518

1. Manufacturers/part numbers are for reference only and are subject to change. Choose connectors that are appropriate for your own design.

Ordering Information

To order, contact the Sierra Wireless Sales Desk at +1 (604) 232-1488 between 8 AM and 5 PM Pacific Time.

Integration Requirements

Sierra Wireless provides, in the document suite, guidelines for successful Mini Card integration and offers integration support services as necessary.

When integrating the MC7455 PCI-Express Mini Card, the following items need to be addressed:

- **Mounting**—Effect on temperature, shock, and vibration performance
- **Power supply**—Impact on battery drain and possible [RF](#) interference
- **Antenna location and type**—Impact on RF performance
- **Regulatory approvals**—As discussed in [Regulatory Compliance and Industry Certifications on page 63](#).
- **Service provisioning**—Manufacturing process
- **Software**—As discussed in [Software Interface on page 55](#).
- **Host Interface**—Compliance with interface voltage levels

2: Standards Compliance

The MC7455 Mini Card complies with the mandatory requirements described in the following standards. The exact set of requirements supported is network operator-dependent.

Table 2-1: Standards Compliance

Technology	Standards
LTE	<ul style="list-style-type: none">• 3GPP Release 11
UMTS	<ul style="list-style-type: none">• 3GPP Release 9

3: Electrical Specifications

The system block diagram in [Figure 3-1 on page 24](#) represents the MC7455 module integrated into a host system. The module includes the following interfaces to the host:

- **Power**—Supplied to the module by the host.
- **W_DISABLE_N**—Input supplied to the module by the host to cause the module to either turn off/on or enter/exit low power mode (software configurable).
- **WAKE_N**—Signal used to wake the host when specific events occur.
- **WAN_LED_N**—Active-low **LED** drive signal provides an indication of RADIO ON state, either WAN or GNSS.
- **SYSTEM_RESET_N**—Active-low reset input.
- **Antenna**—Three U.FL **RF** connectors (main (Rx/Tx), GNSS, and auxiliary (diversity/MIMO/GNSS). For details, see [RF Specifications on page 37](#).
- **Antenna control**—Three signals that can be used to control external antenna switches.
- **Dynamic power control**—Signal used to adjust Tx power to meet FCC/CE SAR requirements. For details, see [Tx Power Control on page 53](#).
- **Dual SIM**—Supported through the interface connector. The **SIM** cavities / connectors must be placed on the host device for this feature.
- **USB**—USB 2.0 and USB 3.0 interfaces to the host for data, control, and status information.

The MC7455 has two main interface areas—the host I/O connector and the **RF** ports. Details of these interfaces are described in the sections that follow.

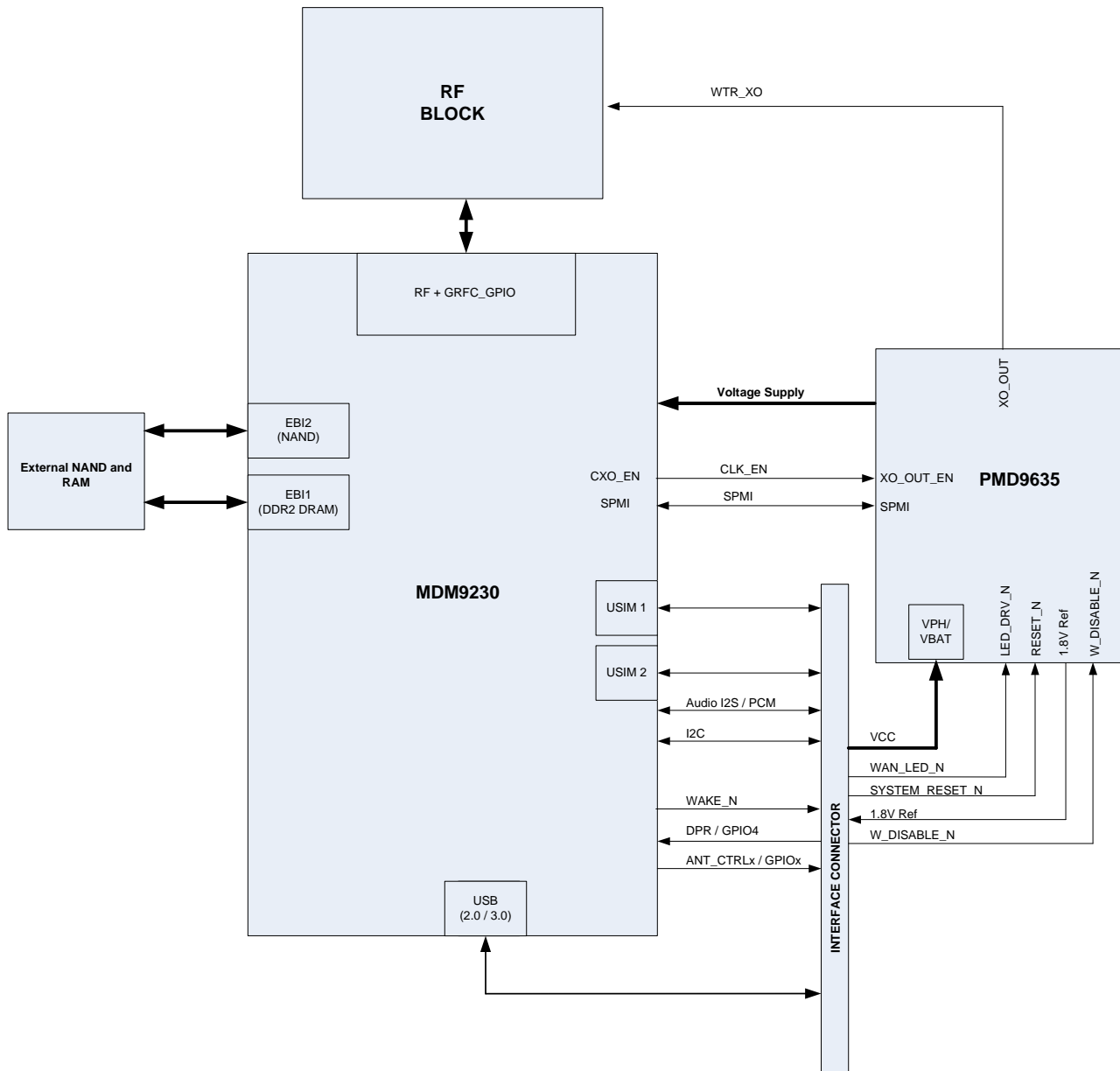

Figure 3-1: System Block Diagram

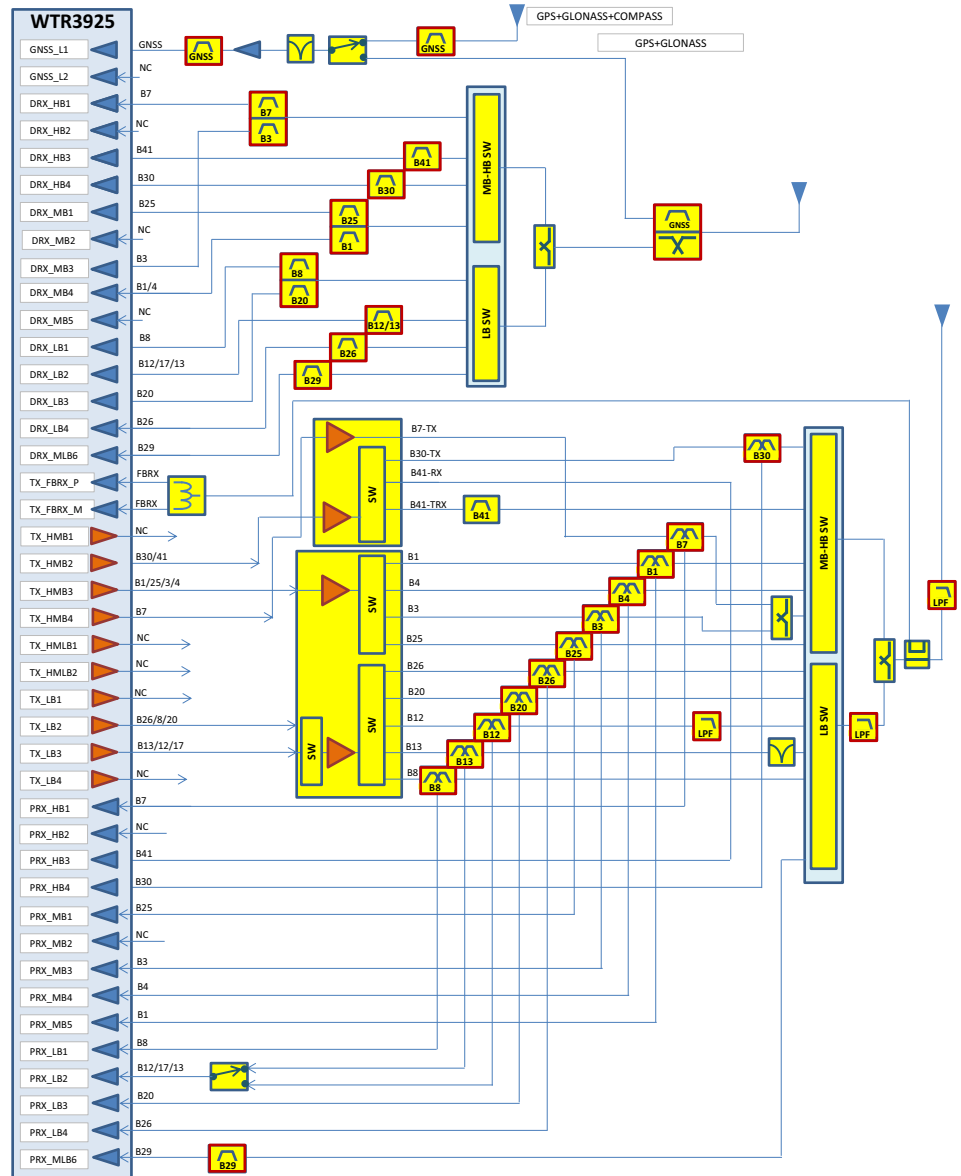

Figure 3-2: Expanded RF Block Diagram

Host Interface Pin Assignments

The MC7455 host I/O connector provides pins for power, serial communications, and control. Pin assignments are listed in [Table 3-1](#).

Refer to the following tables for pin details based on interface types:

- [Table 3-2, Power and Ground Specifications](#), on page 30
- [Table 3-3, USB Interfaces](#), on page 30
- [Table 3-4, SIM Interface Signals](#), on page 31
- [Table 3-5, Module Control Signals](#), on page 34

Note: On any given interface (USB, SIM, etc.), leave unused inputs and outputs as no-connects.

Table 3-1: Connector Pin Assignments¹

Pin	Signal name	Pin type ²	Description	Direction ³	Active state	Voltage levels (V)		
						Min	Typ	Max
1	WAKE_N	OC	Wake host	Output	Low	-	-	0.10
2	VCC	V	Power supply	Input	Power	3.135	3.30	3.60
3	ANT_CTRL0 / GPIO1	-	(ANT_CTRL0) Customer-defined external switch control for multiple antennas	Output	High	1.35	1.80	1.90
				Output	Low	0	-	0.45
			(GPIO1) General purpose I/O	Input High		1.17	1.80	2.10
				Input Low		-0.30		0.63
				Output High		1.35	1.80	1.90
Output Low		0.00		0.45				
4	GND	V	Ground	Input	Power	-	0	-
5	ANT_CTRL1 / GPIO2	-	(ANT_CTRL1) Customer-defined external switch control for multiple antennas	Output	High	1.35	1.80	1.90
				Output	Low	0	-	0.45
			(GPIO2) General purpose I/O	Input High		1.17	1.80	2.10
				Input Low		-0.30		0.63
				Output High		1.35	1.80	1.90
Output Low		0.00		0.45				
6	NC	-	No connect	-	-	-	-	-
7	USIM2_RST	-	SIM 2 Reset	Output	Low	0	-	0.45
					High	2.55 (3V SIM) 1.35 (1.8V SIM)	-	3.10 (3V SIM) 1.90 (1.8V SIM)
8	USIM_PWR	-	SIM VCC supply	Output	Power	2.90 (3V SIM) 1.75 (1.8V SIM)	3.00 (3V SIM) 1.80 (1.8V SIM)	3.10 (3V SIM) 1.85 (1.8V SIM)
9	GND	V	Ground	Input	Power	-	0	-

Table 3-1: Connector Pin Assignments¹ (Continued)

Pin	Signal name	Pin type ²	Description	Direction ³	Active state	Voltage levels (V)		
						Min	Typ	Max
10	USIM_DATA	-	SIM IO pin	Input	Low	-0.30 (3V SIM) -0.30 (1.8V SIM)	-	0.70 (3V SIM) 0.63 (1.8V SIM)
					High	1.95 (3V SIM) 1.17 (1.8V SIM)	3.00 (3V SIM) 1.80 (1.8V SIM)	3.30 (3V SIM) 2.10 (1.8V SIM)
				Output	Low	0	-	0.45
					High	2.55 (3V SIM) 1.35 (1.8V SIM)	3.00 (3V SIM) 1.80 (1.8V SIM)	3.10 (3V SIM) 1.90 (1.8V SIM)
11	VREF_1.8V ⁴	-	1.8V reference voltage output	Output	Power	1.75	1.80	1.85
12	USIM_CLK	-	SIM Clock	Output	Low	0	-	0.45
					High	2.55 (3V SIM) 1.35 (1.8V SIM)	3.00 (3V SIM) 1.80 (1.8V SIM)	3.10 (3V SIM) 1.90 (1.8V SIM)
13	USIM2_PWR	-	SIM 2 VCC supply	Output	Power	2.90 (3V SIM) 1.75 (1.8V SIM)	3.00 (3V SIM) 1.80 (1.8V SIM)	3.10 (3V SIM) 1.85 (1.8V SIM)
14	USIM_RST	-	SIM Reset	Output	Low	0	-	0.45
					High	2.55 (3V SIM) 1.35 (1.8V SIM)	3.00 (3V SIM) 1.80 (1.8V SIM)	3.10 (3V SIM) 1.90 (1.8V SIM)
15	GND	V	Ground	Input	Power	-	0	-
16	NC	-	No connect	-	-	-	-	-
17	USIM2_CLK	-	SIM 2 Clock	Output	Low	0	-	0.45
					High	2.55 (3V SIM) 1.35 (1.8V SIM)	3.00 (3V SIM) 1.80 (1.8V SIM)	3.10 (3V SIM) 1.90 (1.8V SIM)
18	GND	V	Ground	Input	Power	-	0	-
19	USIM2_DATA	-	SIM 2 IO pin	Input	Low	-0.30 (3V SIM) -0.30 (1.8V SIM)	-	0.70 (3V SIM) 0.63 (1.8V SIM)
					High	1.95 (3V SIM) 1.17 (1.8V SIM)	3.00 (3V SIM) 1.80 (1.8V SIM)	3.30 (3V SIM) 2.10 (1.8V SIM)
				Output	Low	0	-	0.45
					High	2.55 (3V SIM) 1.35 (1.8V SIM)	3.00 (3V SIM) 1.80 (1.8V SIM)	3.10 (3V SIM) 1.90 (1.8V SIM)
20	W_DISABLE_N	PU	Turn module on ⁵	Input	High	1.20	-	3.60
			Turn module off ⁵	Input	Low	-0.30	-	0.70
21	GND	V	Ground	Input	Power	-	0	-
22	SYSTEM_RESET_N	OC	Reset	Input	Low	-0.30	-	0.63

Table 3-1: Connector Pin Assignments¹ (Continued)

Pin	Signal name	Pin type ²	Description	Direction ³	Active state	Voltage levels (V)		
						Min	Typ	Max
23	USB3.0_TX-		USB 3.0 Transmit Data negative	Output	Differential	-	-	-
24	VCC	V	Power supply	Input	Power	3.135	3.30	3.60
25	USB3.0_TX+		USB 3.0 Transmit Data positive	Output	Differential	-	-	-
26	GND	V	Ground	Input	Power	-	0	-
27	GND	V	Ground	Input	Power	-	0	-
28	NC	-	No connect	-	-	-	-	-
29	GND	V	Ground	Input	Power	-	0	-
30	NC (For audio interface pin usage, see Audio Support on page 67.)		Reserved— Host must not repurpose this pin.					
31	USB3.0_RX-		USB 3.0 Receive Data negative	Input	Differential	-	-	-
32	NC (For audio interface pin usage, see Audio Support on page 67.)		Reserved— Host must not repurpose this pin.					
33	USB3.0_RX+		USB 3.0 Receive Data positive	Input	Differential	-	-	-
34	GND	V	Ground	Input	Power	-	0	-
35	GND	V	Ground	Input	Power	-	0	-
36	USB_D-	-	USB data negative	Input/Output	Differential	-	-	-
37	GND	V	Ground	Input	Power	-	0	-
38	USB_D+	-	USB data positive	Input/Output	Differential	-	-	-
39	VCC	V	Power supply	Input	Power	3.135	3.30	3.60
40	GND	V	Ground	Input	Power	-	0	-
41	VCC	V	Power supply	Input	Power	3.135	3.30	3.60
42	WAN_LED_N	OC	LED Driver	Output	Low	0	-	0.15
43	GND	V	Ground	Input	Power	-	0	-

Table 3-1: Connector Pin Assignments¹ (Continued)

Pin	Signal name	Pin type ²	Description	Direction ³	Active state	Voltage levels (V)		
						Min	Typ	Max
44	ANT_CTRL2 / GPIO3	-	(ANT_CTRL2) Customer-defined external switch control for multiple antennas	Output	High	1.35	1.80	1.90
				Output	Low	0	-	0.45
			(GPIO3) General purpose I/O	Input High		1.17	1.80	2.10
				Input Low		-0.30		0.63
				Output High		1.35	1.80	1.90
Output Low		0.00		0.45				
45	NC (For audio interface pin usage, see Audio Support on page 67.)		Reserved— Host must not repurpose this pin.					
46	DPR / GPIO4	-	(DPR) Dynamic power control	Input	High	1.17	1.80	2.10
				Input	Low	-0.30	-	0.63
			(GPIO4) General purpose I/O	Input High		1.17	1.80	2.10
				Input Low		-0.30		0.63
				Output High		1.35	1.80	1.90
Output Low		0.00		0.45				
47	NC (For audio interface pin usage, see Audio Support on page 67.)		Reserved— Host must not repurpose this pin.					
48	NC	-	No connect	-	-	-	-	-
49	NC (For audio interface pin usage, see Audio Support on page 67.)		Reserved— Host must not repurpose this pin.					
50	GND	V	Ground	Input	Power	-	0	-
51	NC (For audio interface pin usage, see Audio Support on page 67.)		Reserved— Host must not repurpose this pin.					
52	VCC	V	Power supply	Input	Power	3.135	3.30	3.60

1. The host should leave all 'NC' ('no connect') pins unconnected.
2. A—Analog; I—Input; NP—No pull; O—Digital output; OC—Open Collector; PU—Digital input (internal pull up); PD—Digital output (internal pull down); V—Power or ground
3. Signal directions are from module's point of view (e.g. 'Output' from module to host, 'Input' to module from host.)
4. To avoid adverse effects on module operation, do not draw more than 10 mA current on pin 11.
5. W_DISABLE_N causes the module to either turn off/on or enter/leave low power mode (software configurable).

Power Supply

The host provides power to the MC7455 through multiple power and ground pins as summarized in [Table 3-2](#).

The host must provide safe and continuous power at all times; the module does not have an independent power supply, or protection circuits to guard against electrical issues.

Table 3-2: Power and Ground Specifications

Name	Pins	Specification	Min	Typ	Max	Units
VCC	2, 24, 39, 41, 52	Voltage range	See Table 3-1 on page 26 .			
		Ripple voltage	-	-	100	mV _{pp}
GND	4, 9, 15, 18, 21, 26, 27, 29, 34, 35, 37, 40, 43, 50	-	-	0	-	V

USB Interface

Important: Host support for USB2.0 signals is required.

The device supports USB 2.0 and USB 3.0 interfaces for communication between the host and module.

The interfaces comply with the [10] *Universal Serial Bus Specification, Rev 2.0* and [11] *Universal Serial Bus Specification, Rev 3.0*, and the host device must be designed to the same standards (subject to details shown in [Table 3-3](#) below). (Note: When designing the host device, careful PCB layout practices must be followed.)

Table 3-3: USB Interfaces

	Name	Pin	Description
USB 2.0	USB_D-	36	USB data negative
	USB_D+	38	USB data positive
USB 3.0	USB3.0_TX ⁻¹	23	Transmit data negative
	USB3.0_TX ⁺¹	25	Transmit data positive
	USB3.0_RX ⁻¹	31	Receive data negative
	USB3.0_RX ⁺¹	33	Receive data positive

1. Signal directions (Tx/Rx) are from device's point of view.

USB Throughput Performance

This device has been designed to achieve optimal performance and maximum throughput using USB superspeed mode (USB 3.0). Although the device may operate with a high speed host, throughput performance will be on an “as is” basis and needs to be characterized by the [OEM](#). Note that throughput will be reduced and may vary significantly based on [packet](#) size, host interface, and [firmware](#) revision.

User-developed Drivers

Details for user-developed USB drivers are described in [4] *AirCard/AirPrime USB Driver Developer's Guide (Doc# 2130634)*.

SIM Interface

Note: Host support for SIM interface signals is required.

The module supports up to two SIMs (Subscriber Identity Module) (1.8 V or 3 V). Each SIM holds information for a unique account, allowing users to optimize their use of each account on multiple devices.

The [SIM](#) pins ([Table 3-4](#)) provide the connections necessary to interface to SIM sockets located on the host device as shown in [Figure 3-3 on page 32](#). Voltage levels over this interface comply with 3GPP standards.

The types of SIM connectors used depends on how the host device exposes the SIM sockets.

Table 3-4: SIM Interface Signals

SIM	Name	Pin	Description	SIM contact number ¹	Notes
Primary	USIM_PWR	8	SIM voltage	1	Power supply for SIM
	USIM_DATA	10	Data I/O	7	Bi-directional SIM data line
	USIM_CLK	12	Serial clock	3	Serial clock for SIM data
	USIM_RST	14	Reset	2	Active low SIM reset
	USIM_GND		Ground	5	Ground reference USIM_GND is common to module ground
Secondary	USIM2_PWR	13	SIM voltage	2	Power supply for SIM 2
	USIM2_DATA	19	Data I/O	3	Bi-directional SIM 2 data line
	USIM2_CLK	17	Serial clock	7	Serial clock for SIM 2 data
	USIM2_RST	7	Reset	1	Active low SIM 2 reset
	USIM2_GND		SIM indication	-	Ground reference USIM2_GND is common to module ground

1. See [Figure 3-4 on page 32](#) for SIM card contacts.

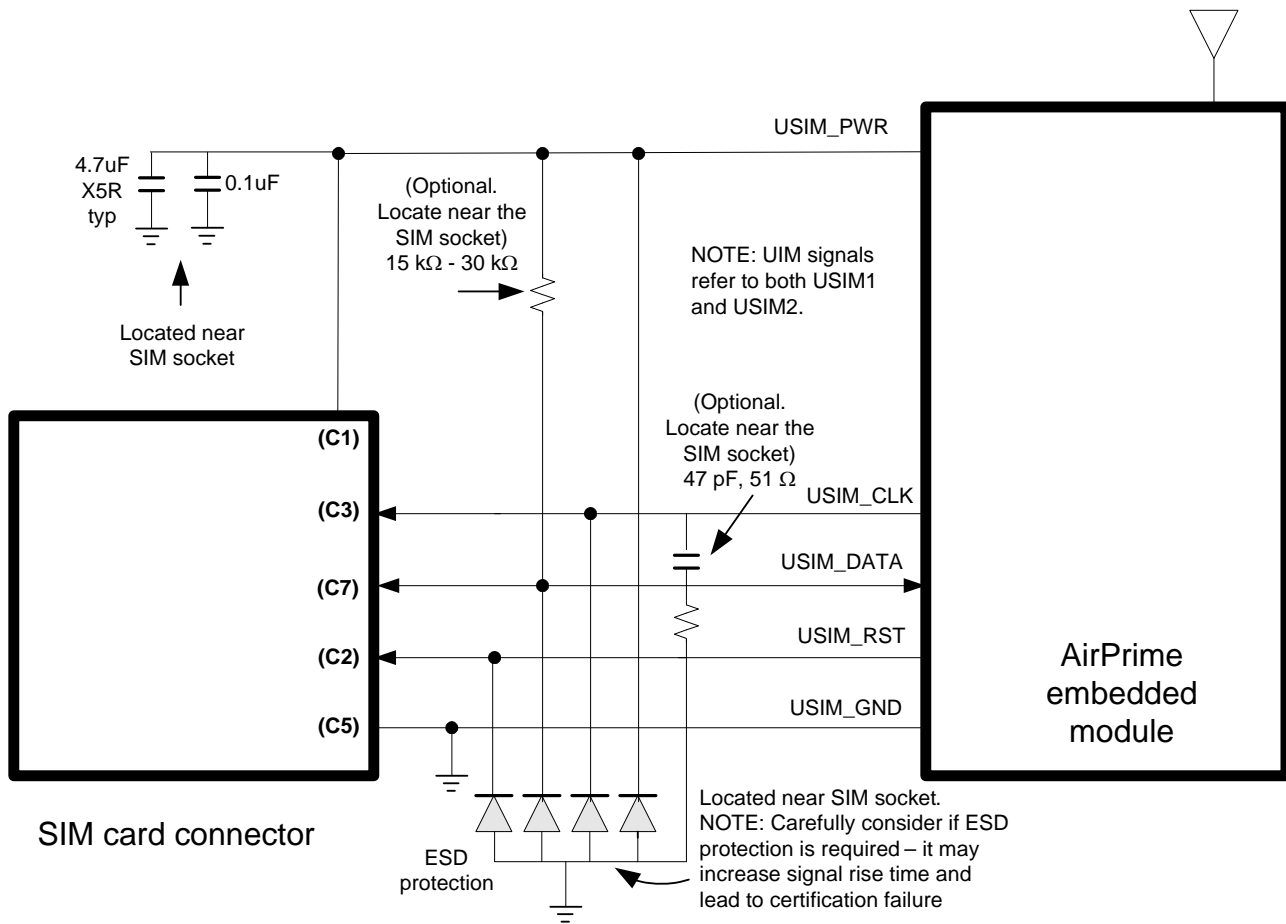

Figure 3-3: SIM Application Interface (applies to both SIM interfaces)

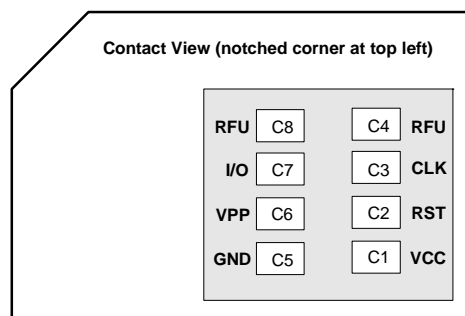

Figure 3-4: SIM Card Contacts (contact view)

SIM Implementation

Note: For interface design requirements, refer to ETSI TS 102 230 V5.5.0, section 5.2.

When designing the remote SIM interface, you *must* make sure that SIM signal integrity is not compromised.

Some design recommendations include:

- Total impedance of the VCC and GND connections to the SIM, measured at the module connector, should be less than $1\ \Omega$ to minimize voltage drop (includes any trace impedance and lumped element components—inductors, filters, etc.).
- Position the SIM connector ≤ 10 cm from the module. If a longer distance is required because of the host device design, use a shielded wire assembly—connect one end as close as possible to the SIM connector and the other end as close as possible to the module connector. The shielded assembly may help shield the SIM interface from system noise.
- Reduce crosstalk on the USIM_DATA and USIM2_DATA lines to reduce the risk of failures during GCF approval testing.
- Avoid routing the clock and data lines for each SIM (USIM_CLK/USIM_DATA, USIM2_CLK/USIM2_DATA) in parallel over distances > 2 cm—cross-coupling of a clock and data line pair can cause failures.
- 3GPP has stringent requirements for I/O rise time ($< 1\ \mu\text{s}$), signal level limits, and noise immunity—consider this carefully when developing your PCB layout.
 - Keep signal rise time $< 1\ \mu\text{s}$ —keep SIM signals as short as possible, and keep very low capacitance traces on the data and clock signals (USIM_CLK, USIM_DATA, USIM2_CLK, USIM2_DATA). High capacitance increases signal rise time, potentially causing your device to fail certification tests.
- Add external pull-up resistors ($15\ \text{k}\Omega$ – $30\ \text{k}\Omega$), if required, between the data and power lines for each SIM (USIM_DATA/USIM_PWR, USIM2_DATA/USIM2_PWR) to optimize the signal rise time.
- VCC line should be decoupled close to the SIM socket.
- SIM is specified to run up to 5 MHz (SIM clock rate). Take note of this speed in the placement and routing of the SIM signals and connectors.
- You must decide whether additional ESD protection is required for your product, as it is dependent on the application, mechanical enclosure, and SIM connector design. The SIM pins will require additional ESD protection if they are exposed to high ESD levels (i.e. can be touched by a user).
- Putting optional decoupling capacitors on the SIM power lines (USIM_PWR, USIM2_PWR) near the SIM sockets is recommended—the longer the trace length (impedance) from the socket to the module, the greater the capacitance requirement to meet compliance tests.
- Putting an optional series capacitor and resistor termination (to ground) on the clock lines (USIM_CLK, USIM2_CLK) at the SIM sockets to reduce EMI and increase signal integrity is recommended if the trace length between the SIM socket and module is long— $47\ \text{pF}$ and $50\ \Omega$ resistor are recommended.
- Test your first prototype host hardware with a Comprion IT³ SIM test device at a suitable testing facility.

Control Interface (Signals)

The MC7455 provides signals for:

- Waking the host when specific events occur
- Host control of module power
- LED driver output

These signals are summarized in [Table 3-5](#) and paragraphs that follow.

Table 3-5: Module Control Signals

Name	Pin	Description	Type ¹
WAKE_N	1	Wake host	OC
W_DISABLE_N	20	On/off signal ²	PU
WAN_LED_N	42	LED driver	OC

1. OC—Open Collector; PU—Digital pin Input, internal pull up
2. W_DISABLE_N causes the module to either turn off/on or enter/leave low power mode (software configurable).

WAKE_N — Wake Host

Note: Host support for WAKE_N is optional.

The module uses WAKE_N to wake the host when specific events occur.

The host must provide a 5 kΩ–100 kΩ pullup resistor that considers total line capacitance (including parasitic capacitance) such that when WAKE_N is deasserted, the line will rise to 3.3 V (Host power rail) in < 100 ns.

See [Figure 3-5 on page 34](#) for a recommended implementation.

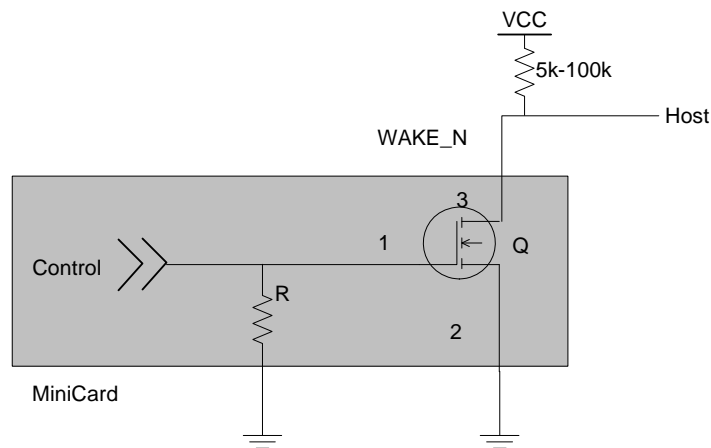

Figure 3-5: Recommended WAKE_N Connection

W_DISABLE_N — Wireless Disable

Note: Host support for W_DISABLE_N is required.

The host uses W_DISABLE_N to cause the module to either turn off/on or enter/leave low power mode, as described in [Table 3-6](#).

For timing details, see [Power-On/Off Timing on page 51](#).

Table 3-6: W_DISABLE_N Usage

Name	Pin	Description/notes
W_DISABLE_N	20	<p>Powers the module on/off (or enters/leaves low power mode)¹.</p> <ul style="list-style-type: none"> Leave as not connected or drive HIGH to keep the modem always on Drive LOW to turn the module off (or enter low power mode). An AT command may be used by the developer to configure this signal so the module enters/leaves low power mode instead of powering on/off (the default behavior)

1. W_DISABLE_N causes the module to either turn off/on or enter/leave low power mode (software configurable).

WAN_LED_N—LED Output

Note: Host support for WAN_LED_N is optional.

The module drives the LED output according to [9] *PCI Express Mini Card Electromechanical Specification Revision 2.1*.

Note: The LED configuration is customizable. Contact your Sierra Wireless account representative for details.

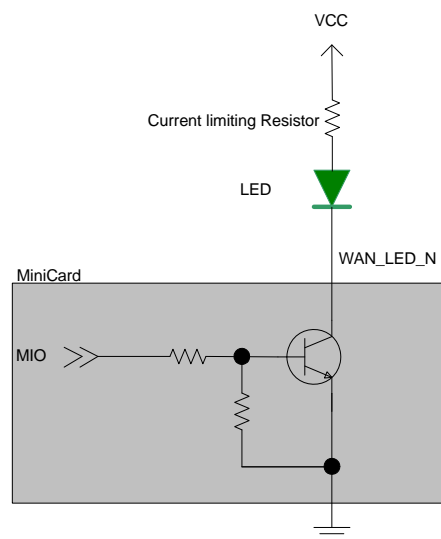

Figure 3-6: Example LED

SYSTEM_RESET_N—Reset Input

Note: Host support for SYSTEM_RESET_N is optional.

SYSTEM_RESET_N has an internal 1.8 V internal pull up that requires an open collector input from the host. Set this signal to active low to reset the device. Note that the minimum pulse width is 3 s.

Antenna Control

Note: Host support for antenna control signals is optional.

The MC7455 Mini Card provides three output signals that may be used for host designs that incorporate tunable antennas. For details, see [2] *AirPrime EM74xx/MC74xx AT Command Reference (Doc# 4117727)*.

Table 3-7: Antenna Control Signals

Name	Pin	Description
ANT_CTRL0	3	Customer-defined external switch control for tunable antennas
ANT_CTRL1	5	
ANT_CTRL2	44	

4: RF Specifications

The MC7455 includes three RF connectors for use with host-supplied antennas:

- Main RF connector—Tx/Rx path
- GNSS RF connector—Dedicated GPS, GLONASS, BeiDou, and Galileo
- Auxiliary RF connector—Diversity, MIMO, GPS, GLONASS, and Galileo

The module does not have integrated antennas.

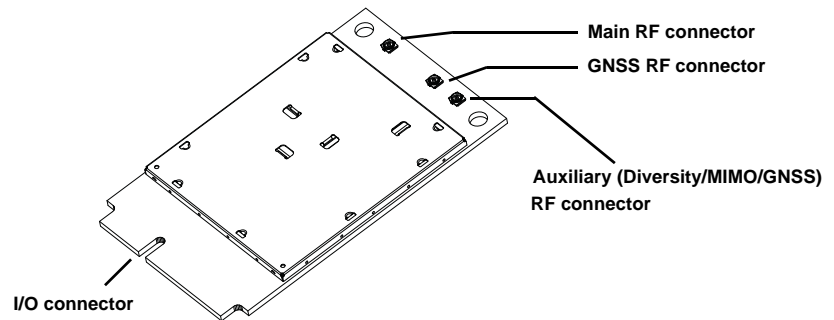

Figure 4-1: Module Connectors

RF Connections

When attaching antennas to the module:

- Use Hirose U.FL connectors (3 mm x 3 mm, low profile; model U.FL #CL331-0471-0-10) to attach antennas to connection points on the module, as shown in [Figure 4-1](#) on page 37.
- Match coaxial connections between the module and the antenna to 50 Ω .
- Minimize RF cable losses to the antenna; the recommended maximum cable loss for antenna cabling is 0.5 dB.
- To ensure best thermal performance, mounting holes must be used to attach (ground) the device to the main PCB ground or a metal chassis.

Note: If the antenna connection is shorted or open, the modem will not sustain permanent damage.

Shielding

The module is fully shielded to protect against EMI and the shield must not be removed.

*Note: To **disconnect** the antenna, make sure you use the Hirose U.FL connector removal tool (P/N UFL-LP-N-2(01)) to prevent damage to the module or coaxial cable assembly.*

Antenna and Cabling

When selecting the antenna and cable, it is critical to RF performance to optimize antenna gain and cable loss.

Note: For detailed electrical performance criteria, see [Appendix B: Antenna Specification](#) on page 71.

Choosing the Correct Antenna and Cabling

When matching antennas and cabling:

- The antenna (and associated circuitry) should have a nominal impedance of 50 Ω with a recommended return loss of better than 10 dB across each frequency band of operation.
- The system gain value affects both radiated power *and* regulatory (FCC, IC, CE, etc.) test results.

Designing Custom Antennas

Consider the following points when designing custom antennas:

- A skilled RF engineer should do the development to ensure that the RF performance is maintained.
- If both CDMA and UMTS modules will be installed in the same platform, you may want to develop separate antennas for maximum performance.

Determining the Antenna's Location

When deciding where to put the antennas:

- Antenna location may affect RF performance. Although the module is shielded to prevent interference in most applications, the placement of the antenna is still very important—if the host device is insufficiently shielded, high levels of broadband noise or spurious interference can degrade the module's performance.
- Connecting cables between the module and the antenna must have 50 Ω impedance. If the impedance of the module is mismatched, RF performance is reduced significantly.
- Antenna cables should be routed, if possible, away from noise sources (switching power supplies, LCD assemblies, etc.). If the cables are near the noise sources, the noise may be coupled into the RF cable and into the antenna. See [Interference From Other Wireless Devices](#) on page 39.

Disabling the Diversity Antenna

Use the AT command `!RXDEN=0` to disable receive diversity or `!RXDEN=1` to enable receive diversity.

Note: A diversity antenna is used to improve connection quality and reliability through redundancy. Because two antennas may experience different interference effects (signal distortion, delay, etc.), when one antenna receives a degraded signal, the other may not be similarly affected.

Ground Connection

When connecting the module to system ground:

- Prevent noise leakage by establishing a very good ground connection to the module through the host connector.
- Connect to system ground using the two mounting holes at the top of the module (shown in [Figure 4-1](#) on page 37).
- Minimize ground noise leakage into the RF.
Depending on the host board design, noise could *potentially* be coupled to the module from the host board. This is mainly an issue for host designs that have signals traveling along the length of the module, or circuitry operating at both ends of the module interconnects.

Interference and Sensitivity

Several interference sources can affect the module's RF performance (RF desense). Common sources include power supply noise and device-generated RF.

RF desense can be addressed through a combination of mitigation techniques ([Methods to Mitigate Decreased Rx Performance on page 40](#)) and radiated sensitivity measurement ([Radiated Sensitivity Measurement on page 40](#)).

Note: The MC7455 is based on ZIF (Zero Intermediate Frequency) technologies. When performing EMC (Electromagnetic Compatibility) tests, there are no IF (Intermediate Frequency) components from the module to consider.

Interference From Other Wireless Devices

Wireless devices operating inside the host device can cause interference that affects the module.

To determine the most suitable locations for antennas on your host device, evaluate each wireless device's radio system, considering the following:

- Any harmonics, sub-harmonics, or cross-products of signals generated by wireless devices that fall in the module's Rx range may cause spurious response, resulting in decreased Rx performance.
- The Tx power and corresponding broadband noise of other wireless devices may overload or increase the noise floor of the module's receiver, resulting in Rx desense.

The severity of this interference depends on the closeness of the other antennas to the module's antenna. To determine suitable locations for each wireless device's antenna, thoroughly evaluate your host device's design.

Host-generated RF Interference

All electronic computing devices generate RF interference that can negatively affect the receive sensitivity of the module.

Proximity of host electronics to the antenna in wireless devices can contribute to decreased Rx performance. Components that are most likely to cause this include:

- Microprocessor and memory
- Display panel and display drivers
- Switching-mode power supplies

Device-generated RF Interference

The module can cause interference with other devices. Wireless devices such as AirPrime embedded modules transmit in bursts (pulse transients) for set durations (RF burst frequencies). Hearing aids and speakers convert these burst frequencies into audible frequencies, resulting in audible noise.

Methods to Mitigate Decreased Rx Performance

It is important to investigate sources of localized interference early in the design cycle. To reduce the effect of device-generated RF on Rx performance:

- Put the antenna as far as possible from sources of interference. The drawback is that the module may be less convenient to use.
- Shield the host device. The module itself is well shielded to avoid external interference. However, the antenna cannot be shielded for obvious reasons. In most instances, it is necessary to employ shielding on the components of the host device (such as the main processor and parallel bus) that have the highest RF emissions.
- Filter out unwanted high-order harmonic energy by using discrete filtering on low frequency lines.
- Form shielding layers around high-speed clock traces by using multi-layer PCBs.
- Route antenna cables away from noise sources.

Radiated Spurious Emissions (RSE)

When designing an antenna for use with AirPrime embedded modules, the host device with an AirPrime embedded module must satisfy any applicable standards/local regulatory bodies for radiated spurious emission (RSE) for receive-only mode and for transmit mode (transmitter is operating).

Note that antenna impedance affects radiated emissions, which must be compared against the conducted 50-ohm emissions baseline. (AirPrime embedded modules meet the 50-ohm conducted emissions requirement.)

Radiated Sensitivity Measurement

A wireless host device contains many noise sources that contribute to a reduction in Rx performance.

To determine the extent of any receiver performance desensitization due to self-generated noise in the host device, over-the-air (OTA) or radiated testing is required. This testing can be performed by Sierra Wireless or you can use your own OTA test chamber for in-house testing.

Sierra Wireless' Sensitivity Testing and Desensitization Investigation

Although AirPrime embedded modules are designed to meet network operator requirements for receiver performance, they are still susceptible to various performance inhibitors.

As part of the Engineering Services package, Sierra Wireless offers modem OTA sensitivity testing and desensitization (desense) investigation. For more information, contact your account manager or the Sales Desk (see [Contact Information on page 4](#)).

Note: Sierra Wireless has the capability to measure TIS (Total Isotropic Sensitivity) and TRP (Total Radiated Power) according to CTIA's published test procedure.

Sensitivity vs. Frequency

For UMTS bands, sensitivity is defined as the input power level in dBm that produces a BER (Bit Error Rate) of 0.1%. Sensitivity should be measured at all UMTS frequencies across each band.

For LTE bands, sensitivity is defined as the RF level at which throughput is 95% of maximum.

Supported Frequencies

The MC7455 supports:

- Multiple-band LTE—See [Table 4-1 on page 41](#).
- LTE Advanced carrier aggregation—See [Table 1-2 on page 16](#).
- Multiple-band WCDMA/HSPA/HSPA+/DC-HSPA+—See [Table 4-2 on page 42](#).
- Multiple-band WCDMA receive diversity
- GPS, GLONASS, BeiDou, Galileo—See [Table 4-6 on page 44](#).
- Inter-RAT and inter-frequency cell reselection and handover between supported frequency bands

Table 4-1: LTE Frequency Bands¹

Band	Frequency (Tx)	Frequency (Rx)
Band 1	1920–1980 MHz	2110–2170 MHz
Band 2	1850–1910 MHz	1930–1990 MHz

Table 4-1: LTE Frequency Bands¹ (Continued)

Band	Frequency (Tx)	Frequency (Rx)
Band 3	1710–1785	1805–1880 MHz
Band 4	1710–1755	2110–2155 MHz
Band 5	824–849 MHz	869–894 MHz
Band 7	2500–2570 MHz	2620–2690 MHz
Band 8	880–915 MHz	925–960 MHz
Band 12	699–716 MHz	729–746 MHz
Band 13	777–787 MHz	746–756 MHz
Band 20	832–862 MHz	791–821 MHz
Band 25	1850–1915 MHz	1930–1995 MHz
Band 26	814–849 MHz	859–894 MHz
Band 29	n/a	717–728 MHz
Band 30	2305–2315 MHz	2350–2360 MHz
Band 41	2496–2690 MHz (TDD)	

1. For bandwidth support details, see *3GPP TS 36.521-1 v11.3.0, table 5.4.2.1-1*

Table 4-2: WCDMA Frequency Bands

Band ¹	Frequency (Tx)	Frequency (Rx)
Band 1	1920–1980 MHz	2110–2170 MHz
Band 2	1850–1910 MHz	1930–1990 MHz
Band 3	1710–1785 MHz	1805–1880 MHz
Band 4	1710–1755 MHz	2110–2155 MHz
Band 5	824–849 MHz	869–894 MHz
Band 8	880–915 MHz	925–960 MHz

1. WCDMA channel spacing is 5 MHz, but this can be adjusted to optimize performance in a particular deployment scenario.

Conducted Rx Sensitivity / Tx Power

Note: All values in the following tables are preliminary, pending transceiver matching and testing.

Table 4-3: Conducted Rx (Receive) Sensitivity — LTE Bands

LTE bands		Conducted Rx sensitivity (dBm)			
		Primary (Typical)	Secondary (Typical)	SIMO (Typical)	SIMO ¹ (Worst case)
LTE Band 1	Full RB BW: 10 MHz ²	-97.5	-97.0	-100.5	-96.3
LTE Band 2		-97.0	-98.0	-100.5	-94.3
LTE Band 3		-97.0	-98.0	-100.0	-93.3
LTE Band 4		-97.5	-97.0	-100.0	-96.3
LTE Band 5		-98.5	-99.0	-102.0	-94.3
LTE Band 7		-96.5	-97.0	-100.0	-94.3
LTE Band 8		-99.0	-98.0	-101.5	-93.3
LTE Band 12		-97.5	-99.0	-101.5	-93.3
LTE Band 13		-97.0	-98.5	-101.0	-93.3
LTE Band 20		-98.5	-98.5	-101.5	-93.3
LTE Band 25		-97.0	-97.5	-100.5	-92.8
LTE Band 26		-98.5	-99.0	-102.0	-93.8
LTE Band 29		n/a	n/a	-101.75	-93.3
LTE Band 30		-95.5	-97.0	-99.5	-95.3
LTE Band 41		-95.5	-95.5	-98.5	-94.3

1. Per 3GPP specification
2. Sensitivity values scale with bandwidth:
 $x_MHz_Sensitivity = 10_MHz_Sensitivity - 10 \cdot \log(10 \text{ MHz}/x_MHz)$
 Note: Bandwidth support is dependent on firmware version.

Table 4-4: Conducted Rx (Receive) Sensitivity—UMTS Bands

UMTS bands		Conducted Rx sensitivity (dBm)		
		Primary (Typical)	Secondary (Typical)	Primary/Secondary (Worst case) ¹
Band 1	0.1% BER 12.2 kbps	-110.5	-109.0	-106.0
Band 2		-110.0	-110.0	-104.0
Band 3		-109.5	-110.0	-103.0
Band 4		-110.0	-109.5	-106.0
Band 5		-111.0	-112.0	-104.0
Band 8		-111.5	-110.5	-103.0

1. Per 3GPP specification

Table 4-5: Conducted Tx (Transmit) Power Tolerances

Parameter	Conducted transmit power	Notes
LTE		
LTE Band 1,2,3,4,5,8,12,13,20,25,26	+23 dBm ± 1 dB	
LTE Band 7,30,41	+22 dBm ± 1 dB	
UMTS		
Band 1 (IMT 2100 12.2 kbps) Band 2 (UMTS 1900 12.2 kbps) Band 3 (UMTS 1800 12.2 kbps) Band 4 (AWS 1700/2100 12.2 kbps) Band 5 (UMTS 850 12.2 kbps) Band 8 (UMTS 900 12.2 kbps)	+23 dBm ± 1 dB	Connectorized (Class 3)

GNSS Specifications

Note: For detailed electrical performance criteria, see [Recommended GNSS Antenna Specifications on page 73](#).

Table 4-6: GNSS Specifications

Parameter/feature	Description
Satellite channels	Maximum 30 channels (16 GPS, 14 GLONASS), simultaneous tracking
Protocols	NMEA 0183 V3.0

Table 4-6: GNSS Specifications (Continued)

Parameter/feature	Description
Acquisition time	Hot start: 1 s Warm start: 29 s Cold start: 32 s <i>Note: Measured with signal strength = -135 dBm.</i>
Accuracy	Horizontal: < 2 m (50%); < 5 m (90%) Altitude: < 4 m (50%); < 8 m (90%) Velocity: < 0.2 m/s
Sensitivity	Tracking ¹ : -160 dBm Acquisition ² (Assisted): -158 dBm Acquisition (Standalone): -145 dBm
Operational limits	Altitude <6000 m or velocity <100 m/s (Either limit may be exceeded, but not both.)

1. Tracking sensitivity is the lowest GNSS signal level for which the device can still detect an in-view satellite 50% of the time when in sequential tracking mode.
2. Acquisition sensitivity is the lowest GNSS signal level for which the device can still detect an in-view satellite 50% of the time.

Power Consumption

Power consumption measurements in the tables below are for the MC7455 Mini Card module connected to the host PC via USB.

The module does not have its own power source and depends on the host device for power. For a description of input voltage requirements, see [Power Supply on page 30](#).

Table 5-1: Averaged Standby DC Power Consumption

Signal	Description	Bands ¹	Current			Notes / configuration	
			Typ	Max ²	Unit		
VCC	Standby current consumption (Sleep mode activated³)						
	LTE	LTE Bands	3.14	3.70	mA	DRX cycle = 8 (2.56 s)	
	DC-HSPA/HSPA / WCDMA	UMTS bands	3.14	3.70	mA	DRX cycle = 8 (2.56 s)	
	Standby current consumption⁴ (Sleep mode deactivated³)						
	LTE	LTE bands	34.7	39.2	mA	DRX cycle = 8 (2.56 s)	
	DC-HSPA/HSPA / WCDMA	UMTS bands	34.7	39.2	mA	DRX cycle = 8 (2.56 s)	
	Low Power Mode (LPM)/Offline Mode⁴ (Sleep mode activated³)						
	RF disabled, but module is operational			2.35	2.91	mA	
	Low Power Mode (LPM)/Offline Mode⁴ (Sleep mode deactivated³)						
	RF disabled, but module is operational			32.5	35.8	mA	

1. For supported bands, see [Table 4-1, LTE Frequency Bands](#), on page 41, and [Table 4-2, WCDMA Frequency Bands](#), on page 42.
2. Measured at 30°C/nominal 3.3 V voltage.
3. Assumes USB bus is fully suspended during measurements
4. LPM and standby power consumption will increase when LEDs are enabled. To reduce power consumption, configure LEDs to remain off while in standby and LPM modes.

Table 5-2: Averaged Call Mode DC Power Consumption

Description	Tx power	Current ¹		Notes
		Typ	Unit	
LTE	0 dBm	649.6	mA	CA 300/50 Mbps, 20 MHz+20 MHz BW
		347.2	mA	CA 100/50 Mbps, 10 MHz+10 MHz BW
		425.6	mA	150/50 Mbps, 20 MHz BW
	20 dBm	1008	mA	CA 300/50 Mbps, 20 MHz+20 MHz BW
		672	mA	CA 100/50 Mbps, 10 MHz+10 MHz BW
		806.4	mA	150/50 Mbps, 20 MHz BW
	23 dBm	1120	mA	CA 300/50 Mbps, 20 MHz+20 MHz BW
		728	mA	CA 100/50 Mbps, 10 MHz+10 MHz BW
		862.4	mA	150/50 Mbps, 20 MHz BW
DC-HSPA/HSPA / WCDMA	0 dBm	324.8	mA	All speeds
	20 dBm	448	mA	All speeds
	23 dBm	593.6	mA	Worst case
TD-SCDMA		tbd		
Peak current (averaged over 100 μs)		2.24	A	All LTE/WCDMA/TD-SCDMA bands

1. Measured at 30°C/nominal 3.3 V voltage

Table 5-3: Miscellaneous DC Power Consumption

Signal	Description	Current/Voltage			Unit	Notes/configuration
		Min	Typ	Max		
VCC	USB active current		11.2	16.8	mA	High speed USB connection, C _L = 50 pF on D+ and D- signals
	Inrush current		840	2800	mA	<ul style="list-style-type: none"> Assumes power supply turn on time > 100μs Dependent on host power supply rise time.
	Maximum current	-	-	1.45	A	<ul style="list-style-type: none"> Across all bands, all temperature ranges 3.3 V supply
GNSS Signal connector	Active bias on GNSS port			100	mA	GNSS RF connector in Figure 4-1 on page 37
		3.05	3.15	3.25	V	

Module Power States

The module has four power states, as described in [Table 5-4](#).

Table 5-4: Module Power States

State	Details	Host is powered	Module is powered	USB interface active	RF enabled
Normal (Default state)	<ul style="list-style-type: none"> Module is active Default state when VCC is first applied in the absence of W_DISABLE_N control Module is capable of placing/receiving calls, or establishing data connections on the wireless network Current consumption is affected by several factors, including: <ul style="list-style-type: none"> Radio band being used Transmit power Receive gain settings Data rate Number of active Tx time slots 	✓	✓	✓	✓
Low power ('Airplane mode')	<ul style="list-style-type: none"> Module is active Module enters this state: <ul style="list-style-type: none"> Under host interface control: <ul style="list-style-type: none"> Host issues AT+CFUN=0 ([1] AT Command Set for User Equipment (UE) (Release 6) (Doc# 3GPP TS 27.007)), or Host issues AT!PCOFFEN=0 (configures the modem to enter low power mode when W_DISABLE_N is asserted), and then asserts W_DISABLE_N Automatically, when critical temperature or voltage trigger limits have been reached 	✓	✓	✓	✗
Sleep	<ul style="list-style-type: none"> Normal state of module between calls or data connections Module cycles between wake (polling the network) and sleep, at network provider-determined interval. 	✓	✓	✗	✗
Disconnected	<ul style="list-style-type: none"> Host power source is disconnected from the module and all voltages associated with the module are at 0 V. 	✗	✗	✗	✗

Power State Transitions

The module uses state machines to monitor supply voltage and operating temperature, and notifies the host when critical threshold limits are exceeded. (See [Table 5-5](#) for trigger details and [Figure 5-1](#) for state machine behavior.)

Power state transitions may occur:

- Automatically, when critical supply voltage or module temperature trigger levels are encountered.
- Under host control, using available AT commands in response to user choices (for example, opting to switch to airplane mode) or operating conditions.

Table 5-5: Power State Transitions (including voltage/temperature trigger levels)

Transition	Voltage		Temperature ¹		Notes
	Trigger	v ²	Trigger	°C	
Normal to Low Power	VOLT_HI_CRIT	3.8	TEMP_LO_CRIT	-45	• RF activity suspended
	VOLT_LO_CRIT	2.9	TEMP_HI_CRIT	90	
Low Power to Normal	VOLT_HI_NORM	3.5	TEMP_NORM_LO	-30	• RF activity resumed
Low Power to Normal or Remain in Normal (Remove warnings)	VOLT_LO_NORM	3.05	TEMP_HI_NORM	70	
Normal (Issue warning)	VOLT_LO_WARN	2.95	TEMP_HI_WARN	80	• In the TEMP_HI_WARN state, the module may have reduced performance (Class B temperature range).
Power off/on (Host-initiated)	-	-	-	-	• Power off recommended when supply voltage or module operating temperature is critically low or high.

1. Module-reported temperatures at the printed circuit board.
 2. Supply voltage—3.3V

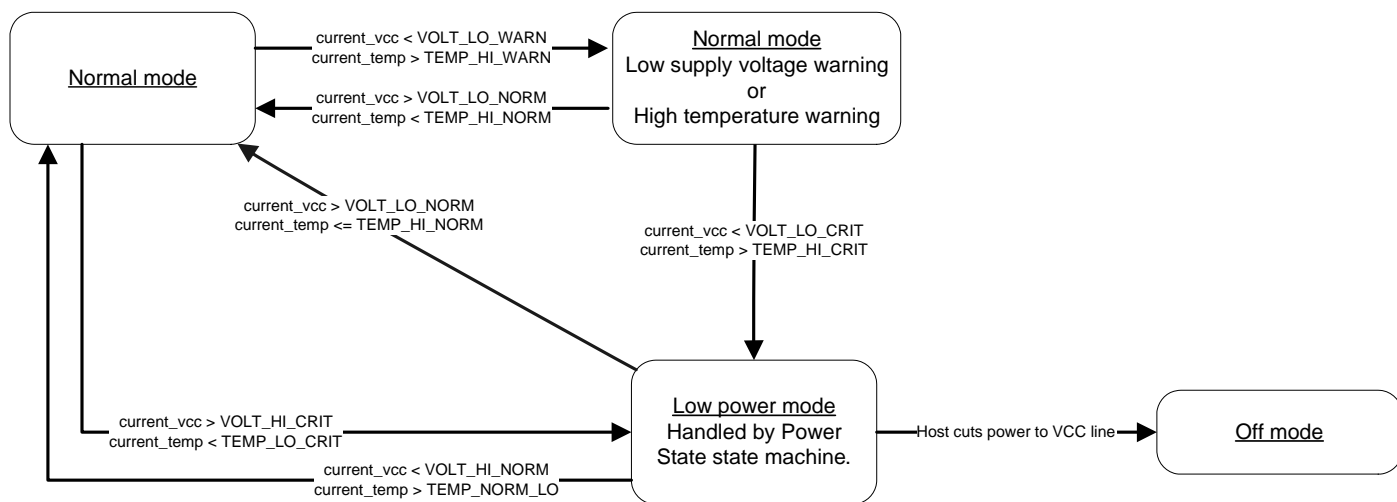

Figure 5-1: Voltage/Temperature Monitoring State Machines

Power Interface

Power Ramp-up

On initial power up, inrush current depends on the power supply rise time—turn on time >100 μs is required for < 3A inrush current.

The supply voltage must remain within specified tolerances while this is occurring.

Power-On/Off Timing

Figure 5-2 describes the timing sequence for powering the module on and off.

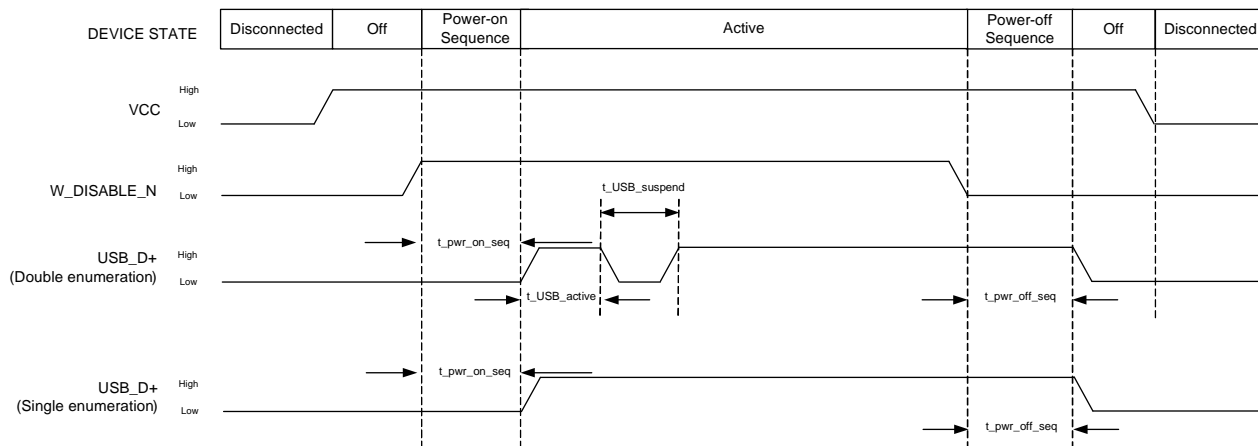

Figure 5-2: Signal Timing (W_DISABLE_N, and USB Enumeration)

Table 5-6: Power-On/Off Timing Parameters (Double Enumeration)

Parameter	Typical (s)	Maximum (s)
t_pwr_on_seq	0.55	0.65
t_USB_active	0.15	0.2
t_USB_suspend	11.5	13
t_pwr_off_seq	12.5	14

Table 5-7: Power-on/off timing parameters (single enumeration)

Parameter	Typical (s)	Maximum (s)
t_pwr_on_seq	11	13
t_pwr_off_seq	12.5	14

USB Enumeration

The unit supports single and double USB enumeration with the host:

- Single enumeration—Enumeration starts within maximum t_pwr_on_seq seconds of power-on.
- Double enumeration—As shown in [Figure 5-2](#) on page 51:
 - First enumeration starts within t_pwr_on_seq seconds of power-on (while USB_D+ is high)
 - Second enumeration starts within 14 seconds of power-on (when USB_D+ goes high again)

Power supply Noise

Noise in the power supply can lead to noise in the RF signal.

The power supply ripple limit for the module is no more than 200 mVp-p 1 Hz to 100 kHz. This limit includes voltage ripple due to transmitter burst activity.

Additional decoupling capacitors can be added to the main VCC line to filter noise into the device.

SED (Smart Error Detection)

The module uses a form of SED to track premature modem resets.

- Module tracks consecutive resets occurring soon after power-on.
- After a sixth consecutive reset, the module waits in boot-and-hold mode for a firmware download to resolve the power-cycle problem.

Tx Power Control

The module's Tx power limit may be controlled using either SAR backoff AT commands (defined in [2] *AirPrime EM74xx/MC74xx AT Command Reference (Doc# 4117727)*), or the DPR (Dynamic power control) signal. Use the GPIOARENABLE parameter for !CUSTOM to choose the method:

- AT commands:
 - !SARSTATED—Set (or report) the default SAR backoff state that the device uses when it powers up. This setting persists across power cycles and overrides any PRI setting.
 - !SARSTATE—Set (or report) the current SAR backoff state (override the default state). This change in state is non-persistent across power cycles.
 - !SARBACKOFF—Set (or report) the maximum Tx power limit for a specific band/technology/state combination.
- Dynamic power control—The module's firmware monitors DPR (pin 46) and adjusts the RF Tx power appropriately, as detailed in [Table 5-8](#). (This state change is equivalent to using the !SARSTATE AT command.)

Note: A customization is available to invert the DPR logic. (e.g. DPR low = No SAR backoff)

Table 5-8: Dynamic Power Control of SAR Backoff State

DPR	SAR backoff state
High ¹	No SAR backoff
Low	Backoff 1

1. DPR is pulled high by default.

Note: The host can implement an open collector drive for the DPR pin (if a 1.8 V-compatible drive is not available.)

6: Software Interface

Support Tools

The MC7455 is compatible with the following support tools from Sierra Wireless and authorized third parties:

- Firmware update utilities from Sierra Wireless
- Sierra Wireless Logger
- QXDM from QUALCOMM
- QUALCOMM Product Support Tool (QPST)
- Windows and Linux SDKs (including API and drivers)

USB Interface

The device supports the following protocols for modem communication:

- Qualcomm QMI interface. (Please contact your Sierra Wireless account representative for QMI interface documentation.)
- MBIM (Mobile Broadband Interface Model)

MTU Size (Windows 7)

The MTU (Maximum Transmission Unit) size is configured using a driver installer command line option:

MTUSize=<value> (<value> is the size in bytes)

Example:

```
driverinstaller /MTUSize=1428
```

Note: Wireless network operators will have their own specific MTU requirements.

7: Mechanical and Environmental Specifications

The MC7455 module complies with the mechanical and environmental specifications in [Table 7-1](#). Final product conformance to these specifications depends on the [OEM](#) device implementation.

Table 7-1: Mechanical and Environmental Specifications

	Mode	Details
Ambient temperature	Operational Class A	-30°C to +70°C – 3GPP compliant
	Operational Class B	-40°C to +85°C – non-3GPP compliant (reduced operating parameters required)
	Non-operational	-40°C to +85°C, 96 hours (from MIL-STD 202 Method 108)
Relative humidity	Non-operational	85°C, 85% relative humidity for 48 hours (non-condensing)
Vibration	Non-operational	Random vibration, 10 to 2000 Hz, 0.1 g ² /Hz to 0.0005 g ² /Hz, in each of three mutually perpendicular axes. Test duration of 60 minutes for each axis, for a total test time of three hours.
Shock	Non-operational	Half sine shock, 11 ms, 30 g, 8x each axis. Half sine shock, 6 ms, 100 g, 3x each axis.
Drop	Non-operational	1 m on concrete on each of six faces, two times (module only).
(Electrostatic discharge (See Electrostatic Discharge (ESD) on page 59.)	Operational	The RF port (antenna launch and RF connector) complies with the IEC 61000-4-2 standard: <ul style="list-style-type: none"> Electrostatic Discharge Immunity: Test: Level3 Contact Discharge: ±6 kV Air Discharge: ±8 kV
	Non-operational	The host connector Interface complies with the following standard only: <ul style="list-style-type: none"> minimum ±500 V Human Body Model (JESD22-A114-B)
Thermal considerations		See Thermal Considerations on page 60.
Form factor		PCI-Express Mini Card shielded with metal and metalized fabric (F2 specification)
Dimensions		Length: 50.95 mm Width: 30 mm Thickness: 2.75 mm (max) Weight: 8.7 g

Device Views

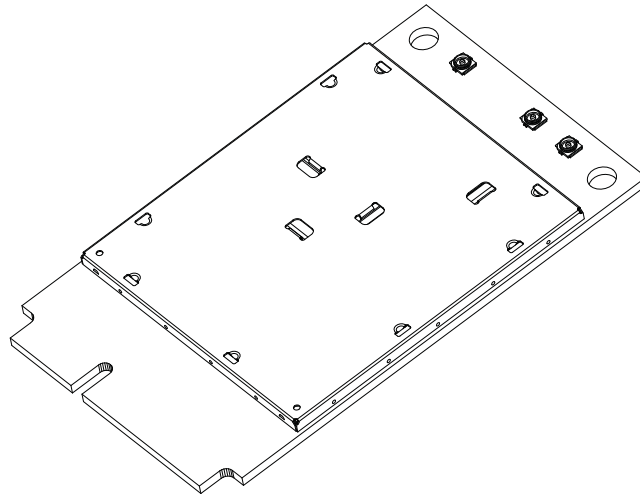

Figure 7-1: Top View

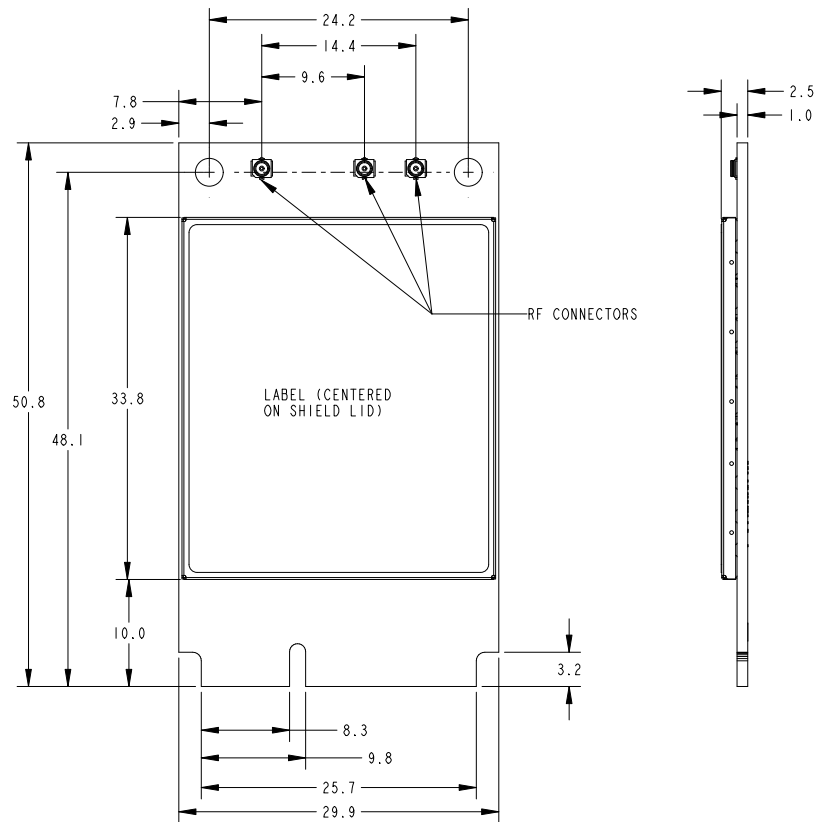

Figure 7-2: Dimensioned View

Labeling

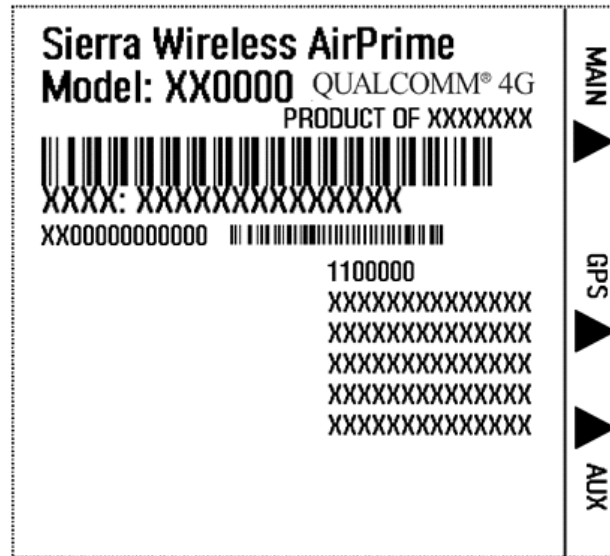

Figure 7-3: Sample Unit Label

Note: The displayed label is an example only. The production label will vary by [SKU](#).

The MC7455 label is non-removable and contains:

- Sierra Wireless logo and product name
- [IMEI](#) number in Code-128 barcode format
- [SKU](#) number (when required)
- Factory Serial Number ([FSN](#)) in alphanumeric format
- Manufacturing date code (incorporated into FSN)
- Licensed vendor logo
- Applicable certification marks/details (e.g. FCC ID, CE information, etc. Example shows FCC ID.)

Note: The MC7455 supports [OEM](#) partner-specific label requirements.

Electrostatic Discharge (ESD)

The OEM is responsible for ensuring that the Mini Card host interface pins are not exposed to ESD during handling or normal operation. (See [Table 7-1 on page 57](#) for specifications.)

ESD protection is highly recommended for the SIM connector at the point where the contacts are exposed, and for any other signals from the host interface that would be subjected to ESD by the user of the product. (The device includes ESD protection on the antenna.)

Thermal Considerations

Embedded modules can generate significant amounts of heat that must be dissipated in the host device for safety and performance reasons.

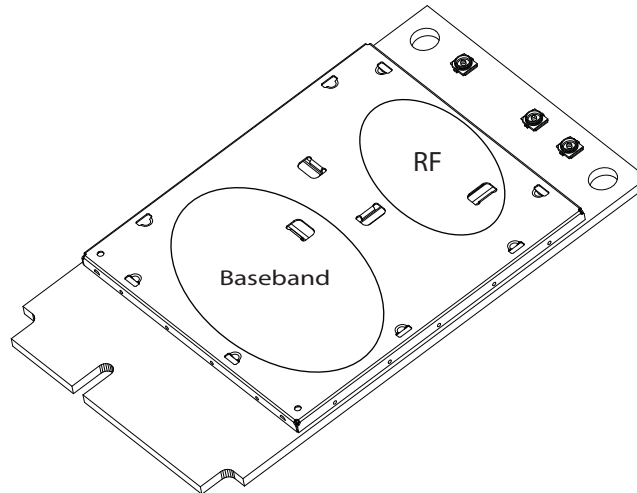

Figure 7-4: Shield locations (Top view)

The amount of thermal dissipation required depends on:

- Supply voltage—Maximum power dissipation for the module can be up to 3.5 W at voltage supply limits.
- Usage—Typical power dissipation values depend on the location within the host product, throughput, amount of data transferred, etc.

Specific areas requiring heat dissipation are shown in [Figure 7-4](#):

- RF—Bottom face of module near RF connectors. Likely to be the hottest area.
- Baseband—Bottom face of module, below the baseband area.

To enhance heat dissipation:

- It is recommended to add a heat sink that mounts the module to the main PCB or metal chassis (a thermal compound or pads must be used between the module and the heat sink).
- Maximize airflow over/around the module.
- Locate the module away from other hot components.
- Module mounting holes must be used to attach (ground) the device to the main PCB ground or a metal chassis.
- You may also need active cooling to pull heat away from the module.

Note: Adequate dissipation of heat is necessary to ensure that the module functions properly.

Module Integration Testing

When testing your integration design:

- Test to your worst case operating environment conditions (temperature and voltage)
- Test using worst case operation (transmitter on 100% duty cycle, maximum power)
- Monitor temperature on the underside of the module. Attach thermocouples to the areas indicated in [Figure 7-4](#) on page 60 (Baseband, RF).
- Monitor the module's internal temperature using the command **AT!PCTEMP**. (See [2] *AirPrime EM74xx/MC74xx AT Command Reference* (Doc# 4117727).)

Note: Make sure that your system design provides sufficient cooling for the module—proper mounting, heat sinks, and active cooling may be required, depending on the integrated application.

The internal module temperature (reported by AT!PCTEMP) must be kept to <90°C when integrated to prevent damage to the module's components. For best performance, keep the internal module temperature below 80°C.

(For acceptance, certification, quality, and production (including RF) test suggestions, see [Testing on page 77](#).)

8: Regulatory Compliance and Industry Certifications

This module is designed to meet, and upon commercial release, will meet the requirements of the following¹ regulatory bodies and regulations, where applicable:

- Federal Communications Commission (FCC) of the United States
- The Certification and Engineering Bureau of Industry Canada (IC)
- The National Communications Commission (NCC) of Taiwan, Republic of China
- Ministry of Internal Affairs and Communications (MIC) of Japan
- Radio Equipment and Telecommunications Terminal Equipment (R&TTE) Directive of the European Union

Upon commercial release, the following industry certifications will have been obtained, where applicable:

- GCF
- PTCRB

Additional certifications and details on specific country approvals may be obtained upon customer request—contact your Sierra Wireless account representative for details.

Additional testing and certification may be required for the end product with an embedded MC7455 module and are the responsibility of the [OEM](#). Sierra Wireless offers professional services-based assistance to OEMs with the testing and certification process, if required.

Important Notice

Because of the nature of wireless communications, transmission and reception of data can never be guaranteed. Data may be delayed, corrupted (i.e., have errors) or be totally lost. Although significant delays or losses of data are rare when wireless devices such as the Sierra Wireless module are used in a normal manner with a well-constructed network, the Sierra Wireless module should not be used in situations where failure to transmit or receive data could result in damage of any kind to the user or any other party, including but not limited to personal injury, death, or loss of property. Sierra Wireless and its affiliates accept no responsibility for damages of any kind resulting from delays or errors in data transmitted or received using the Sierra Wireless module, or for failure of the Sierra Wireless module to transmit or receive such data.

1. Sample listing of regulatory bodies, final list tbd.

Safety and hazards

Do not operate your MC7455 module:

- In areas where blasting is in progress
- Where explosive atmospheres may be present including refuelling points, fuel depots, and chemical plants
- Near medical equipment, life support equipment, or any equipment which may be susceptible to any form of radio interference. In such areas, the MC7455 module **MUST BE POWERED OFF**. Otherwise, the MC7455 module can transmit signals that could interfere with this equipment.

In an aircraft, the MC7455 module **MUST BE POWERED OFF**. Otherwise, the MC7455 module can transmit signals that could interfere with various onboard systems and may be dangerous to the operation of the aircraft or disrupt the cellular network. Use of a cellular phone in an aircraft is illegal in some jurisdictions. Failure to observe this instruction may lead to suspension or denial of cellular telephone services to the offender, or legal action or both.

Some airlines may permit the use of cellular phones while the aircraft is on the ground and the door is open. The MC7455 module may be used normally at this time.

Important compliance information for North American users

Note: Details are preliminary and subject to change.

The MC7455 module, upon commercial release, will have been granted modular approval for mobile applications. Integrators may use the MC7455 module in their final products without additional FCC/IC (Industry Canada) certification if they meet the following conditions. Otherwise, additional FCC/IC approvals must be obtained.

1. At least 20 cm separation distance between the antenna and the user's body must be maintained at all times.
2. To comply with FCC / IC regulations limiting both maximum RF output power and human exposure to RF radiation, the maximum antenna gain including cable loss in a mobile-only exposure condition must not exceed the limits stipulated in [Table 8-1 on page 65](#).

Table 8-1: Antenna Gain Specifications

Device	Technology	Band	Frequency (MHz)	Maximum antenna gain (dBi)
MC7455 Mini Card	LTE	2	1850–1910	6
		4	1710–1755	6
		5	824–849	6
		7	2500–2570	9
		12	699–716	6
		13	777–787	6
		25	1850–1915	6
		26	814–849	6
		30	2305–2315	1
		41	2496–2690	9
	UMTS	2	1850–1910	6
		4	1710–1755	6
		5	824–849	6

3. The MC7455 module may transmit simultaneously with other collocated radio transmitters within a host device, provided the following conditions are met:
- Each collocated radio transmitter has been certified by FCC/IC for mobile application.
 - At least 20 cm separation distance between the antennas of the collocated transmitters and the user's body must be maintained at all times.
 - The output power and antenna gain in a collocated configuration must not exceed the limits and configurations stipulated in [Table 8-2](#).

Table 8-2: Collocated Radio Transmitter Specifications

Device	Technology	Frequency (MHz)	EIRP Limit (dBm)
Collocated transmitters ¹	WLAN	2400–2500	25
		5150–5850	27
	WiMAX	2300–2400	25
		2500–2700	25
		3300–3800	25
	BT	2400–2500	15

1. Valid collocated transmitter combinations: WLAN+BT; WiMAX+BT. (WLAN+WiMAX+BT is not permitted.)

4. A label must be affixed to the outside of the end product into which the MC7455 module is incorporated, with a statement similar to the following:
 - **This device contains FCC ID: N7NMC7455.**
Contains transmitter module IC: 2417C-MC7455 where 2417C-MC73542417C-MC7355 is the module's certification number.
5. A user manual with the end product must clearly indicate the operating requirements and conditions that must be observed to ensure compliance with current FCC / IC RF exposure guidelines.

The end product with an embedded MC7455 module may also need to pass the FCC Part 15 unintentional emission testing requirements and be properly authorized per FCC Part 15.

Note: If this module is intended for use in a portable device, you are responsible for separate approval to satisfy the SAR requirements of FCC Part 2.1093 and IC RSS-102.

➤➤ A: Audio Support

A

The MC7455 host I/O connector provides pins to support PCM or I2S audio interfaces as listed in Table A-1.

Table A-1: Connector Pin Assignments^a

Pin	Signal name	Pin type ^b	Description	Direction to module	Active state	Voltage levels (V)		
						Min	Typ	Max
30	I2C_CLK ^{c,d}	-	I2C serial bus clock	Input High		1.17	1.80	2.10
				Input Low		-0.30		0.63
				Output High		1.35	1.80	1.90
				Output Low		0.00		0.45
32	I2C_DATA ^{c,d}	-	I2C serial bus data	Input High		1.17	1.80	2.10
				Input Low		-0.3		0.63
				Output High		1.35	1.80	1.90
				Output Low		0.00		0.45
45	PCM_CLK / I2S_CLK ^e	-	(PCM_CLK) PCM Clock—Input in Slave mode, output in Master mode	Input High		1.17	1.80	2.10
				Input Low		-0.30		0.63
				Output High		1.35	1.80	1.90
				Output Low		0.00		0.45
			(I2S_CLK) I ² S Clock	Output	High	1.35	-	1.90
				Output	Low	0	-	0.45
47	PCM_DOUT / I2S_DOUT ^e	-	PCM Data Out / I ² S Data Out	Output	High	1.35	1.80	1.90
				Output	Low	0		0.45
49	PCM_DIN / I2S_DIN ^e	-	PCM Data In / I ² S Data In	Input	High	1.17	1.80	2.10
				Input	Low	-0.30		0.63
51	PCM_WS / I2S_SYNC ^e	-	PCM Sync—Input in Slave mode, output in Master mode	Input High		1.17	1.80	2.10
				Input Low		-0.30		0.63
				Output High		1.35	1.80	1.90
				Output Low		0.00		0.45
			I ² S WS	Output	High	1.35	-	1.90
				Output	Low	0	-	0.45

- a. The host should leave all 'NC' ('no connect) pins unconnected.
- b. A—Analog; I—Input; NP—No pull; O—Digital output; OC—Open Collector; PU—Digital input (internal pull up); PD—Digital output (internal pull down); V—Power or ground
- c. Leave both I2C pins as No Connect if I2C interface is not used.
- d. Clock speed: TBD
- e. PCM Master/Slave mode and I2S Master mode are supported.

PCM/I2S Audio Interface

The module implements a PCM/I²S digital audio interface using a dedicated serial link for digital audio data; all other signals, such as subcoding and control, are transmitted separately. Default setting is PCM slave mode, but this can be switched, using AT commands, to PCM master mode, I²S master mode, or I²S slave mode.

PCM/I²S signals are summarized in the following table.

Table A-2: PCM/I²S Interface Signals

Signal name	Pin	Description
PCM_CLK/I2S_CLK	45	PCM Clock/I2S Clock
PCM_DOUT/I2S_DOUT	47	PCM Data Out/I2S Data Out
PCM_DIN/I2S_DIN	49	PCM Data In/I2S Data In
PCM_SYNC/I2S_WS	51	PCM Sync/I2S Word Select

PCM

The PCM interface supports the following features:

- Modes: Master and slave
- Auxiliary PCM This is in EM, is it in mc as well?
- Sampling rates: 8 kHz, 16 kHz
- Audio compression formats: Linear, μ -law, A-Law
- Padding: Disabled, enabled
- Bits per frame: 8, 16, 32, 64, 128, 256
- Bit frequency: (Sampling rate * Bits per frame)

The following figures and table illustrate PCM signals timing.

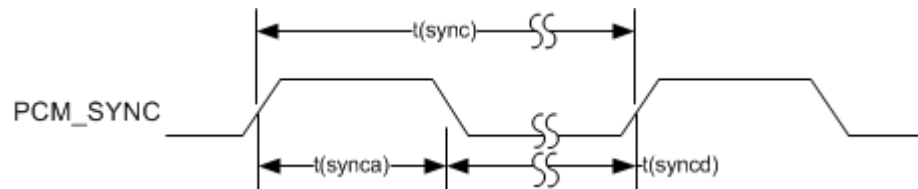

Figure A-1: Timing—PCM_SYNC

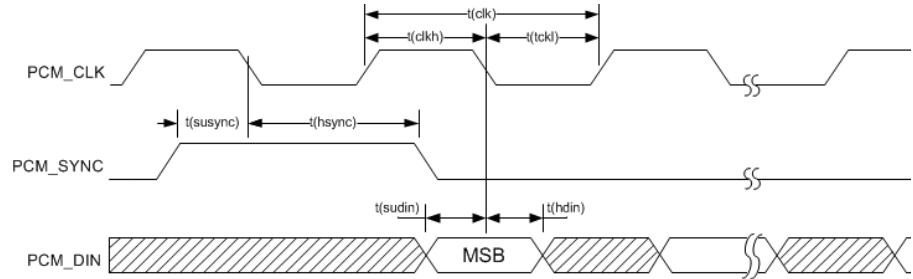

Figure A-2: Timing—PCM codec to module

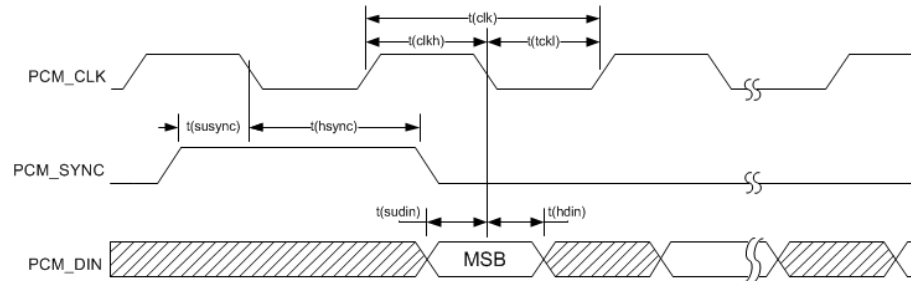

Figure A-3: Timing—Module to PCM Codec

Table A-3: PCM Timing^a

Parameter	Description	Min	Typ	Max	Units
T(sync)	PCM_FS cycle time	-	125	-	us
T(synch)	PCM_FS high time	-	488	-	ns
T(cyncl)	PCM_FS low time	-	124.5	-	us
T(clk)	PCM_CLK cycle time	-	488	-	NS
T(clkh)	PCM_CLK high time	-	244	-	ns
T(clkl)	PCM_CLK low time	-	244	-	ns
T(sync_offset)	PCM_SYNC offset time to PCM_CLK falling	-	122	-	ns
T(sudin)	PCM_DIN setup time before falling edge of PCM_CLK	60	-	-	NS
T(hdin)	PCM_DIN hold time after falling edge of PCM_CLK	60	-	-	ns
T(pdout)	Delay from PCM_CLK rising to PCM_DOUT valid	-	-	60	ns
T(zdout)	Delay from PCM_CLK falling to PCM_DOUT HIGH-Z	-	-	60	ns

a. Maximum PCM clock rate is 2.048 MHz.

I²S

The I²S interface can be used to transfer serial digital audio to or from an external stereo DAC/ADC and supports the following features:

- Modes: Master (Slave mode is not supported)
- Sampling rates: 48 kHz
- Bits per frame: 16

- Bit clock: 1536 kHz

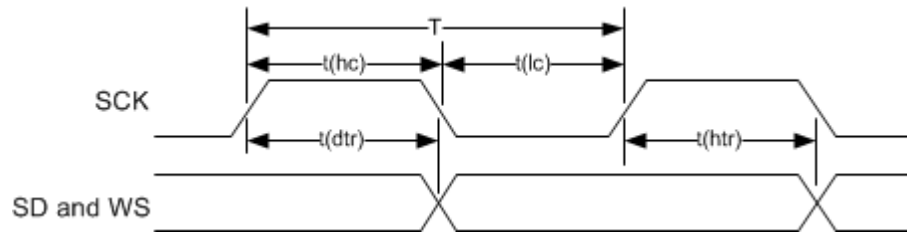

Figure A-4: I2S Transmitter Timing

Table A-4: Master Transmitter With Data Rate = 1.536 MHz ($\pm 10\%$)^a

Parameter	Description	Condition	Min	Typ	Max	Units
T	Clock period	I2S requirement: min $T=293$	293	326	359	ns
t(hc)	Clock high	I2S requirement: min $> 0.35T$	120	-	-	ns
t(lc)	Clock low	I2S requirement: min $> 0.35T$	120	-	-	ns
t(dtr)	Delay	I2S requirement: max $< 0.8T$	-	-	250	ns
t(htr)	Hold time	I2S requirement: min > 0	100	-	-	ns

a. Maximum sample rate = 48 KHz at 1.536 MHz (16 bits per sample)

»» B: Antenna Specification

B

This appendix describes recommended electrical performance criteria for main path, diversity path, and GNSS antennas used with AirPrime embedded modules.

The performance specifications described in this section are valid while antennas are mounted in the host device with antenna feed cables routed in their final application configuration.

*Note: Antennas should be designed **before** the industrial design is finished to make sure that the best antennas can be developed.*

Recommended Main/Diversity Antenna Specifications

Table B-1: Antenna Requirements ^a

Parameter	Requirements	Comments
Antenna system	(LTE) External multi-band 2x2 MIMO antenna system (Ant1/Ant2) ^b (3G) External multi-band antenna system with diversity (Ant1/Ant2) ^c	If Ant2 includes GNSS, then it must also satisfy requirements in Table B-2 on page 73 .
Operating bands — Antenna 1	669–960 MHz	
	1710–1995 MHz	
	2110–2170 MHz	
	2300–2690 MHz	
Operating bands — Antenna 2	717–960 MHz	
	1805–1995 MHz	
	2110–2170 MHz	
	2350–2690 MHz	
VSWR of Ant1 and Ant2	<ul style="list-style-type: none"> < 2:1 (recommended) < 3:1 (worst case) 	On all bands including band edges

Table B-1: Antenna Requirements (Continued)^a

Parameter	Requirements	Comments
Total radiated efficiency of Ant1 and Ant2	> 50% on all bands	<ul style="list-style-type: none"> Measured at the RF connector. Includes mismatch losses, losses in the matching circuit, and antenna losses, excluding cable loss. Sierra Wireless recommends using antenna efficiency as the primary parameter for evaluating the antenna system. Peak gain is not a good indication of antenna performance when integrated with a host device (the antenna does not provide omni-directional gain patterns). Peak gain can be affected by antenna size, location, design type, etc.—the antenna gain patterns remain fixed unless one or more of these parameters change.
Radiation patterns of Ant1 and Ant2	Nominally Omni-directional radiation pattern in azimuth plane.	
Envelope correlation coefficient between Ant1 and Ant2	<ul style="list-style-type: none"> tbd 	
Mean Effective Gain of Ant1 and Ant2 (MEG1, MEG2)	≥ -3 dBi	
Ant1 and Ant2 Mean Effective Gain Imbalance I MEG1 / MEG2 I	< 2 dB for MIMO operation < 6 dB for diversity operation	
Maximum antenna gain	Must not exceed antenna gains due to RF exposure and ERP/ EIRP limits, as listed in the module's FCC grant.	See Important compliance information for North American users on page 64 .

Table B-1: Antenna Requirements (Continued)^a

Parameter	Requirements	Comments
Isolation between Ant1 and Ant2 (S21)	> 10 dB	<ul style="list-style-type: none"> If antennas can be moved, test all positions for both antennas. Make sure all other wireless devices (Bluetooth or WLAN antennas, etc.) are turned OFF to avoid interference.
Power handling	<ul style="list-style-type: none"> > 2 W RF power on low bands > 1 W on high bands 	<ul style="list-style-type: none"> Measure power endurance over 4 hours (estimated talk time) using a 2 W CW signal—set the CW test signal frequency to the middle of the PCS Tx band (1880 MHz for PCS). Visually inspect device to ensure there is no damage to the antenna structure and matching components. VSWR/TIS/TRP measurements taken before and after this test must show similar results.

- a. These worst-case VSWR figures for the transmitter bands may not guarantee RSE levels to be within regulatory limits. The device alone meets all regulatory emissions limits when tested into a cabled (conducted) 50 ohm system. With antenna designs with up to 2.5:1 VSWR or worse, the radiated emissions could exceed limits. The antenna system may need to be tuned in order to meet the RSE limits as the complex match between the module and antenna can cause unwanted levels of emissions. Tuning may include antenna pattern changes, phase/delay adjustment, passive component matching. Examples of the application test limits would be included in FCC Part 22, Part 24 and Part 27, test case 4.2.2 for WCDMA (ETSI EN 301 908-1), where applicable.
- b. Ant1—Primary, Ant2—Secondary (Diversity/MIMO/GNSS)
- c. Ant1—Primary, Ant2—Secondary (Diversity/GNSS)

Recommended GNSS Antenna Specifications

Table B-2: GNSS Antenna Requirements

Parameter	Requirements	Comments
Frequency range	<ul style="list-style-type: none"> Wide-band GNSS: 1560–1606 MHz recommended Narrow-band GPS: 1575.42 MHz \pm2 MHz minimum Narrow-band Galileo: 1575.42 MHz \pm2 MHz minimum Narrow-band BeiDou: 1561.098 MHz \pm2 MHz minimum Narrow-band GLONASS: 1601.72 MHz \pm4.2 MHz minimum 	
Field of view (FOV)	<ul style="list-style-type: none"> Omni-directional in azimuth -45° to +90° in elevation 	

Table B-2: GNSS Antenna Requirements (Continued)

Parameter	Requirements	Comments
Polarization (average Gv/Gh)	> 0 dBi	Vertical linear polarization is sufficient.
Free space average gain (Gv+Gh) over FOV	> -6 dBi (preferably > -3 dBi)	Gv and Gh are measured and averaged over -45° to +90° in elevation, and ±180° in azimuth.
Gain	<ul style="list-style-type: none"> Maximum gain and uniform coverage in the high elevation angle and zenith. Gain in azimuth plane is not desired. 	
Average 3D gain	> -5 dBi	
Isolation between GNSS and Ant1	> 10 dB in all uplink bands	
Typical VSWR	< 2.5:1	
Polarization	Any other than LHCP (left-hand circular polarized) is acceptable.	

Antenna Tests

The following guidelines apply to the requirements described in [Table B-1 on page 71](#) and [Table B-2 on page 73](#):

- Perform electrical measurements at room temperature (+20°C to +26°C) unless otherwise specified
- For main and diversity path antennas, make sure the antennas (including contact device, coaxial cable, connectors, and matching circuit with no more than six components, if required) have nominal impedances of 50 Ω across supported frequency bands.
- All tests (except isolation/correlation coefficient)—Test the main or diversity antenna with the other antenna terminated.
- Any metallic part of the antenna system that is exposed to the outside environment needs to meet the electrostatic discharge tests per IEC61000-4-2 (conducted discharge +8kV).
- The functional requirements of the antenna system are tested and verified while the embedded module’s antenna is integrated in the host device.

Note: Additional testing, including active performance tests, mechanical, and accelerated life tests can be discussed with Sierra Wireless’ engineering services. Contact your Sierra Wireless representative for assistance.

»» C: Design Checklist

This chapter provides a summary of the design considerations mentioned throughout this guide. This includes items relating to the power interface, RF integration, thermal considerations, cabling issues, and so on.

Note: This is NOT an exhaustive list of design considerations. It is expected that you will employ good design practices and engineering principles in your integration.

Table C-1: Hardware Integration Design Considerations

Suggestion	Section where discussed
Component placement	
Protect the SIM socket so the SIM cannot be removed while the host is powered up.	SIM Implementation on page 33
If an ESD suppressor is not used, allow space on the SIM connector for series resistors in layout. (Up to 100 Ω may be used depending on ESD testing requirements).	SIM Implementation on page 33
Minimize RF cable losses as these affect performance values listed in product specification documents.	RF Connections on page 37
Antennas	
Match the module/antenna coax connections to 50 Ω —mismatched antenna impedance and cable loss negatively affect RF performance.	RF Connections on page 37
If installing CDMA and UMTS modules in the same device, consider using separate antennas for maximum performance.	Antenna and Cabling on page 38
Power	
Make sure the power supply can handle the maximum current specified for the module type.	Power Consumption on page 47
Limit the total impedance of VCC and GND connections to the SIM at the connector to less than 1 Ω (including any trace impedance and lumped element components—inductors, filters, etc.). All other lines must have a trace impedance less than 2 Ω .	SIM Implementation on page 33
Decouple the VCC line close to the SIM socket. The longer the trace length (impedance) from socket to module, the greater the capacitance requirement to meet compliance tests.	SIM Implementation on page 33
PCB signal routing	
USB 2.0/3.0—Route these signals over 90 Ω differential lines on the PCB.	
I2C port—If supported, route these signals away from noise-sensitive signals on the PCB.	

Table C-1: Hardware Integration Design Considerations (Continued)

Suggestion	Section where discussed
PCM port—If supported, route these signals away from noise-sensitive signals on the PCB.	
EMI/ESD	
Investigate sources of localized interference early in the design cycle.	Methods to Mitigate Decreased Rx Performance on page 40
Provide ESD protection for the SIM connector at the exposed contact point (in particular, the CLK, VCC, IO, and RESET lines).	SIM Implementation on page 33
Keep very low capacitance traces on the USIM_DATA and USIM_CLK signals.	SIM Implementation on page 33
To minimize noise leakage, establish a very good ground connection between the module and host.	Ground Connection on page 39
Route cables away from noise sources (for example, power supplies, LCD assemblies, etc.).	Methods to Mitigate Decreased Rx Performance on page 40
Shield high RF-emitting components of the host device (for example, main processor, parallel bus, etc.).	Methods to Mitigate Decreased Rx Performance on page 40
Use discrete filtering on low frequency lines to filter out unwanted high-order harmonic energy.	Methods to Mitigate Decreased Rx Performance on page 40
Use multi-layer PCBs to form shielding layers around high-speed clock traces.	Methods to Mitigate Decreased Rx Performance on page 40
Thermal	
Test to worst case operating conditions—temperature, voltage, and operation mode (transmitter on 100% duty cycle, maximum power).	Thermal Considerations on page 60
Use appropriate techniques to reduce module temperatures (for example, airflow, heat sinks, heat-relief tape, module placement, etc.).	Thermal Considerations on page 60
Host/Modem communication	
Make sure the host USB driver supports remote wakeup, resume, and suspend operations, and serial port emulation.	<i>[4] AirCard/AirPrime USB Driver Developer's Guide (Doc# 2130634)</i>
When no valid data is being sent, do not send SOF tokens from the host (causes unnecessary power consumption).	<i>[4] AirCard/AirPrime USB Driver Developer's Guide (Doc# 2130634)</i>

Note: All AirPrime embedded modules are factory-tested to ensure they conform to published product specifications.

Developers of OEM devices integrating Sierra Wireless AirPrime embedded modules should include a series of test phases in their manufacturing process to make sure that *their* devices work properly with the embedded modules.

Suggested phases include:

- [Acceptance Testing](#)—Testing of modules when they are received from Sierra Wireless
- [Certification Testing](#)—Testing of completed devices to obtain required certifications before beginning mass production
- [Production Testing](#)—Testing of completed devices with the modules embedded
- [Quality Assurance Testing](#)—Post-production

AT Command Entry Timing Requirement

Some AT commands require time to process before additional commands are entered. For example, the modem will return “OK” when it receives `AT!DAFTMACT`. However, if `AT!DASBAND` is received too soon after this, the modem will return an error.

When building automated test scripts, ensure that sufficient delays are embedded where necessary to avoid these errors.

Acceptance Testing

*Note: Acceptance testing is typically performed for **each** shipment received.*

When you receive a shipment from Sierra Wireless, you should make sure it is suitable before beginning production.

From a random sampling of units, test that:

- Units are operational
- Units are loaded with the correct firmware version

Acceptance Test Requirements

To perform the suggested tests, you require a test system in which to temporarily install the module, and you must be able to observe the test device's LED indicator.

Acceptance Test Procedure

The following is a suggested acceptance testing procedure using Sierra Wireless' Skylight™ software:

Note: You can perform these tests using appropriate AT commands.

Test 1: Check Power-up and Initialization

1. After installing the module, start the test system.
2. Launch Skylight.
3. Check the LED—If the LED is off, there is a problem with the module or with the connection to the LED.

Test 2: Check Version Numbers

1. From Skylight, select **Help > About**.
2. Verify that the firmware version in the **About** window is correct.
3. Close the **About** window.

If the module fails either of these tests, or is not recognized by Skylight:

1. Replace the module with one that is known to work correctly and repeat the tests.
2. If the tests are successful, reinstall the original module and repeat the tests.

If the module still does not work correctly, contact your account manager.

Certification Testing

Note: Typically, certification testing of your device with the integrated module is required one time only.

The AirPrime embedded module has been certified as described in [Regulatory Compliance and Industry Certifications on page 63](#).

When you produce a host device with a Sierra Wireless AirPrime embedded module, you must obtain certifications for the final product from appropriate regulatory bodies in the jurisdictions where it will be distributed.

The following are *some* of the regulatory bodies from which you may require certification—it is your responsibility to make sure that you obtain all necessary certifications for your product from these or other groups:

- FCC (Federal Communications Commission—www.fcc.gov)
- Industry Canada (www.ic.gc.ca)

- GCF (Global Certification Forum—www.globalcertificationforum.org) outside of North America
- PTCRB (PCS Type Certification Review Board—www.ptcrb.com) in North America

Production Testing

Note: Production testing typically continues for the life of the product.

Production testing ensures that, for each assembled device, the module is installed correctly (I/O signals are passed between the host and module), and the antenna is connected and performing to specifications (RF tests).

Typical items to test include:

- Host connectivity
- Baseband (host/module connectors)
- RF assembly (Tx and/or Rx, as appropriate)
- Network availability
- Host/device configuration issues

*Note: The amount and types of tests to perform are **your** decision—the tests listed in this section are guidelines only. Make sure that the tests you perform exercise functionality to the degree that **your** situation requires.*

Use an appropriate test station for your testing environment (see [Acceptance Test Requirements on page 78](#) for suggestions) and use AT commands to control the integrated module.

Note: Your test location must be protected from ESD to avoid interference with the module and antenna(s), assuming that your test computer is in a disassembled state. Also, consider using an RF shielding box—local government regulations may prohibit unauthorized transmissions.

Functional Production Test

This section presents a suggested procedure for performing a basic manual functional test on a laboratory bench using an AirPrime embedded module and a Mini Card Dev Kit. When you have become familiar with the testing method, use it to develop your own automated production testing procedures.

Suggested Production Tests

Consider the following tests when you design your production test procedures for devices with the AirPrime module installed.

- Visual check of the module's connectors and RF assemblies
- Module is operational

- USB connection is functional
- LED is functional
- W_DISABLE_N (enter low power mode)
- Firmware revision check
- Rx tests on main and auxiliary paths
- Tx test

Production Test Procedure

The following is a suggested test plan—you must decide which tests are appropriate for your product. You may wish to add additional tests that more fully exercise the capabilities of your product.

Using an appropriate Dev Kit-based test station, and referring to the appropriate AT command references:

1. Visually inspect the module's connectors and RF assemblies for obvious defects before installing it in the test station.
2. Ensure that the module is powered off (no voltage on VCC).
3. If using Linux, determine if any USB devices are currently connected to the computer:
 - a. Open a shell window and enter the command `ls /dev/tty/USB*`.
 - b. Record the `ttyUSBn` values that are returned; these are the currently connected USB devices. If the command returns “no such file or directory”, there are no devices currently connected.
4. Provide power to the module (voltage on VCC).
5. Test W_DISABLE_N.
6. Test USB functionality—Check for USB enumeration.
 - (Windows systems) The Device Manager shows the device under Network adapters. For example:



- (Linux systems) Enter the command `ls /dev/tty/USB*` and then record and compare the results with those from [Step 3](#). If there are any new `ttyUSBn` devices, then the modem has enumerated successfully. (The AT port is the *last* new device.)
7. Make sure your modem is connected and running, and then establish contact with the module:
 - **Windows systems:** Use a terminal emulation/communications program such as Microsoft HyperTerminal® to connect to the Sierra Wireless modem (see listings in [Step 6](#)):
 - a. Start HyperTerminal.

- b. Select **File > Connection Description**. The Connection Description dialog box appears.
 - i. Type Sierra in the Name box and click **OK**. The Connect To dialog box appears.
 - ii. Click **OK** without changing any of the displayed information. The Connect dialog box appears.
 - iii. Click **Cancel**.
 - iv. Type **ATZ** in the HyperTerminal window. If the connection is established, the message OK appears.
- **Linux systems:** Use a terminal emulation/communications program such as minicom to connect over the device handle for AT commands (see listings in [Step 6](#)):

*Note: If necessary, use **ATE1** to enable echo.*

Note: If the command “minicom” is not found, then use a different program, or download minicom and repeat this step. See [Downloading and Configuring minicom for Linux Systems on page 82](#) for details.

- i. Start minicom:
 - First use of the modem: From the command line, type minicom -s. (The ‘-s’ switch shows the configuration menu.)
 - Subsequent uses: From the command line, type minicom. (The ‘-s’ switch is assumed.)

The minicom configuration details appear and the message OK appears when the connection is established.

```

cx Telnet 00.0.00.00
Welcome to minicom 2.2
OPTIONS: I18n
Compiled on Apr 27 2007, 15:50:20.
Port /dev/ttyUSB2

Press CTRL-A Z for help on special keys

AT S7=45 S0=0 L1 U1 X4 &c1 E1 Q0
OK
CTRL-A Z for help !115200 8N1 ! NOR ! Minicom 2.2 ! UT102 ! Offline

```

8. Display the firmware version:
 - **AT+GMR**
9. Test the LED—Set the LED in blinking mode using this command, then visually verify that the LED turns off and on:
 - **AT!LDTEST=0,0** (LED on)
 - **AT!LDTEST=0,1** (LED off)
10. Unlock the extended AT command set (Note: Use **AT!ENTERCND?** to check command syntax, which is SKU-dependent.):
 - **AT!ENTERCN="<password>"**
11. Put the module in diagnostic/factory test mode:
 - **AT!DAFTMACT**
12. Communicate with the SIM using **+CPIN** or **+CIMI**.
When performing RF tests, use a test platform as described in [Suggested Testing Equipment on page 89](#).
13. Test RF transmission, if desired:
 - (UMTS) See [UMTS \(WCDMA\) RF Transmission Path Test on page 82](#).
 - (LTE) To test the LTE transmission path, use a call box.
14. Test RF reception, if desired:
 - (UMTS) See [UMTS \(WCDMA\) RF Receive Path Test on page 84](#).

- (LTE) See [LTE RF Receive Path Test on page 86](#).

15. Test standalone GNSS functionality—See [GNSS RF Receive Path Test on page 88](#).

Downloading and Configuring minicom for Linux Systems

Note: This procedure is for Ubuntu systems. If you are using a different Linux distribution, use the appropriate commands for your system to download minicom.

To download and configure minicom in a Ubuntu system:

Note: To install minicom, you must have root access, or be included in the sudoers list.

1. Download and install minicom—enter the following command:
`sudo apt-get install minicom`
2. When prompted, enter your user password to begin the download and installation. When minicom is installed, the shell prompt appears.
3. Configure minicom to communicate with your modem:
 - a. Start minicom with the following command:
`minicom -s`
4. Use the down-arrow key to select the **Serial port setup** option.
5. Refer to [Step 6](#) on page 80 to identify the device file handle (/dev/ttyUSBn) used for AT commands.
6. Indicate the file handle to use for AT commands—Enter A and then replace the serial device string with the AT file handle.
7. Press **Enter** twice.
8. Use the down-arrow key to select **Save setup as dfi**.
9. Select **Exit**.

UMTS (WCDMA) RF Transmission Path Test

Note: This procedure is performed in [Step 13](#) of the [Production Test Procedure on page 80](#).

The suggested test procedure that follows uses the parameters in [Table D-1](#).

Table D-1: Test Settings—UMTS Transmission Path

	Band	Band ID	Tx Channel^a
2100 MHz	Band 1	9	9750
1900 MHz	Band 2	15 ^b	9400
1800 MHz	Band 3	25	1112
1700 MHz	Band 4	28	1412

Table D-1: Test Settings—UMTS Transmission Path (Continued)

	Band	Band ID	Tx Channel ^a
850 MHz	Band 5	22	4182
900 MHz	Band 8	29	2787

- a. Channel values shown are at the center of the corresponding bands.
- b. Either 15 (WCDMA1900A) or 16 (WCDMA1900B) may be used for testing.

To test the DUT's transmitter path:

1. Set up the power meter:

Note: This procedure describes steps using the "Power Meter: Gigatronics 8651A" (with Option 12 and Power Sensor 80701A).



- a. Make sure the meter has been given sufficient time to warm up, if necessary, to enable it to take accurate measurements.
 - b. Zero-calibrate the meter.
 - c. Enable MAP mode.
2. Prepare the DUT using the following AT commands:
 - a. `ATIINTERCND=<password>` (Unlock extended AT command set.)
 - b. `ATIDAFTMACT` (Enter test mode.)
 - c. `ATIDASBAND=<bandValue>` (Set frequency band.)
 - See [Table D-1 on page 82](#) for appropriate <bandValue> values
 - d. `ATIDASCHAN=<channel>` (Set modem channel)
 - See [Table D-1 on page 82](#) for appropriate <channel> values
 - e. `ATIDASTXON` (Turns on the transmit path.)
 - f. `ATIDAWSTXCW=0` (Use a modulated carrier.)
`ATIDASPD=2, 75` (Set the power level. Repeat command with different offsets until desired Tx power is obtained.)
`ATIDAWSPARANGE=3` (Set to high PA gain state.)
 - g. Offset the tracking (If necessary, repeat with different offsets until the desired frequency is obtained.)
`ATIDASPD=4,35100`
 - h. Take the measurement.
 - i. `ATIDASTXOFF` (Turn off the transmitter.)

3. Test limits—Run ten or more good DUTs through this test procedure to obtain a nominal output power value.
 - Apply a tolerance of ± 5 to 6 dB to each measurement (assuming a good setup design).
 - Monitor these limits during mass-production ramp-up to determine if further adjustments are needed.

Note: The module has a nominal output power of +23 dBm ± 1 dB in WCDMA mode. However, the value measured by the power meter is significantly influenced (beyond the stated ± 1 dB output power tolerance) by the test setup (host RF cabling loss, antenna efficiency and pattern, test antenna efficiency and pattern, and choice of shield box).

Note: When doing the same test over the air in an RF chamber, values are likely to be significantly lower.

UMTS (WCDMA) RF Receive Path Test

Note: This procedure is performed in [Step 14](#) of the [Production Test Procedure on page 80](#).

The suggested test procedure that follows uses the parameters in [Table D-2](#).

Table D-2: Test Settings—UMTS Receive Path

	Band #	Frequency ^a (MHz)	Band ID	Rx Channel ^b
2100 MHz	Band 1	2141.20	9	9750
1900 MHz	Band 2	1961.20	15 ^c	9400
1800 MHz	Band 3	1843.70	25	1112
1700 MHz	Band 4	2133.20	28	1412
850 MHz	Band 5	882.60	22	4182
900 MHz	Band 8	948.60	29	2787

- a. Receive frequencies shown are 1.2 MHz offset from center
- b. Channel values shown are at the center of the corresponding bands.
- c. Either 15 (WCDMA1900A) or 16 (WCDMA1900B) may be used for testing.

Note: This procedure describes steps using the Agilent 8648C signal generator—the Rohde & Schwarz SML03 is shown for reference only.

To test the DUT's receive path:

1. Set up the signal generator:

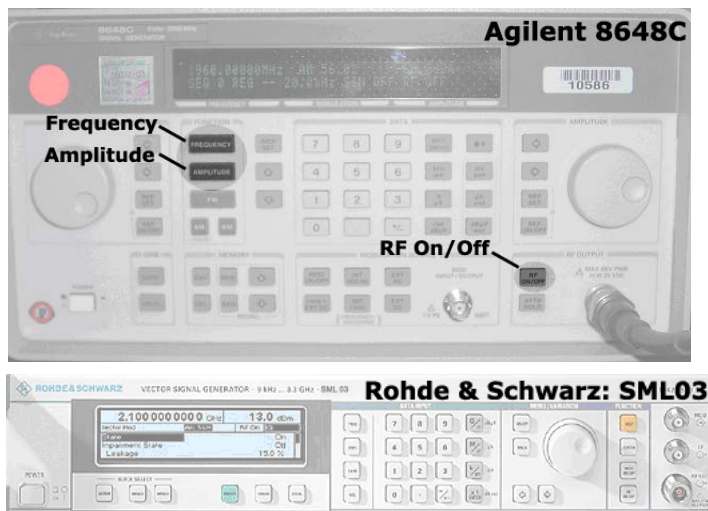

- a. Set the amplitude to:
 - -80 dBm
 - b. Set the frequency for the band being tested. See [Table D-2 on page 84](#) for frequency values.
2. Set up the DUT:
- a. `ATIINTERCND=<password>` (Unlock extended AT command set.)
 - b. `ATIDAFTMACT` (Put modem into factory test mode.)
 - c. `ATIDASBAND=<band>` (Set frequency band.)
 - See [Table D-2 on page 84](#) for <band> values
 - d. `ATIDASCHAN=<channel>` (Set modem channel)
 - See [Table D-2 on page 84](#) for <channel> values
 - e. `ATIDASLNAGAIN=0` (Set the LNA to maximum gain.)
 - f. `ATIDAWGAVGAGC=9400,0` (For PCS1900, channel 9400 as an example.)
The returned value is the RSSI in dBm.
3. Test limits—Run ten or more good DUTs through this test procedure to obtain a nominal received power value.
- Apply a tolerance of ± 5 to 6 dB to each measurement (assuming a good setup design).
 - Make sure the measurement is made at a high enough level that it is not influenced by DUT-generated and ambient noise.
 - The Signal Generator power level can be adjusted and new limits found if the radiated test needs greater signal strength.
 - Monitor these limits during mass-production ramp-up to determine if further adjustments are needed.

Note: The value measured from the DUT is significantly influenced by the test setup and DUT design (host RF cabling loss, antenna efficiency and pattern, test antenna efficiency and pattern, and choice of shield box).

Note: Setup of the DUT is the same as in Step 2, except for a change to AT!DAWGAVGAGC and the addition of AT!DAWSSCHAIN.

4. Test diversity paths:
 - a. Set up the signal generator as in [Step 1](#).
 - b. Set up the DUT:
 - i. AT!ENTERCND="<password>" (Unlock extended AT command set.)
 - ii. AT!DAFTMACT (Put modem into factory test mode.)
 - iii. AT!DASBAND=<band> (Set frequency band.)
 - See [Table D-2 on page 84](#) for <band> values
 - iv. AT!DAWSSCHAIN=1 (Enable the secondary chain.)
 - v. AT!DASCHAN=<channel> (Set modem channel)
 - See [Table D-2 on page 84](#) for <channel> values
 - vi. AT!DASLNAGAIN=0 (Set the LNA to maximum gain.)
 - vii. AT!DAWGAVGAGC=9400,0,1 (The '1' indicates the diversity path is used.)
 - c. Test the limits as in [Step 3](#).

LTE RF Receive Path Test

Note: This procedure is performed in Step 14 of the [Production Test Procedure on page 80](#).

The suggested test procedure that follows uses the parameters in [Table D-3](#).

Table D-3: Test Settings—LTE Receive Path

	Band #	Frequency ^a (MHz)	Band ID	Rx Channel ^b
2100 MHz	Band 1	2142.00	34	18300
1900 MHz	Band 2	1962.00	43	18900
1800 MHz	Band 3	1844.50	44	19575
1700 MHz	Band 4	2134.50	42	20175
850 MHz	Band 5	883.50	45	20525
2600 MHz	Band 7	2657.00	35	21100
900 MHz	Band 8	944.50	47	21625
700 MHz	Band 12	739.50	50	23095
700 MHz	Band 13	753.00	36	23230
800 MHz	Band 20	808.00	56	24300
1900 MHz (G Block)	Band 25	1964.50	61	26365
850 MHz	Band 26	878.50	62	26865
2300 MHz	Band 30	2357.00	66	27710
2500 MHz	Band 41	2595.00	76	40620

- a. Receive frequencies shown are 2 MHz offset from center
- b. Channel values shown are at the center of the corresponding bands.

To test the DUT's receive path (or diversity path, while connected to the diversity antenna):

Note: This procedure describes steps using the Agilent 8648C signal generator—the Rohde & Schwarz SML03 is shown for reference only.

1. Set up the signal generator:

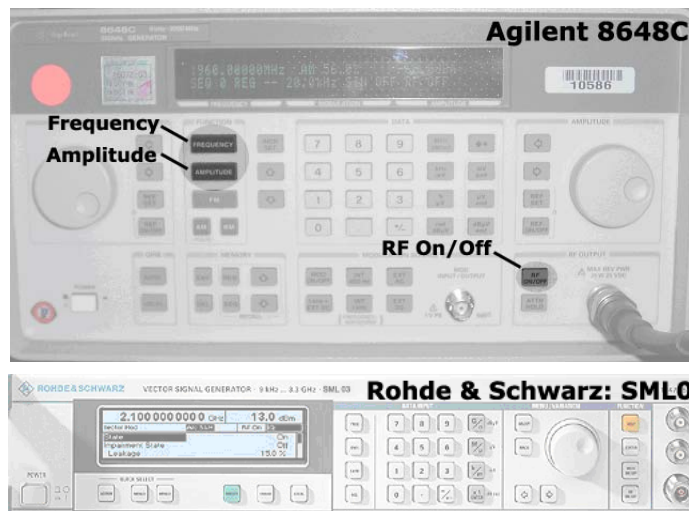

- a. Set the amplitude to -70 dBm
 - b. Set the frequency for the band being tested. See [Table D-3 on page 86](#) for frequency values.
2. Set up the DUT:
 - a. ATIENTERCND="<password>" (Unlock extended AT command set.)
 - b. ATIDAFTMACT (Put modem into factory test mode.)
 - c. ATIDASBAND=<band> (Set frequency band.)
 - See [Table D-3 on page 86](#) for <band> values
 - d. ATIDALSTXBW=<bw> (Set Tx bandwidth.)
 - e. ATIDALSRXBW=<bw> (Set Rx bandwidth.)
 - f. ATIDASCHAN=<channel> (Set modem channel.)
 - See [Table D-3 on page 86](#) for <channel> values
 - g. ATIDALGAVGAGC=<channel>,0 (Get averaged Rx AGC.)
 - See [Table D-3 on page 86](#) for <channel> values
 3. Test limits—Run ten or more good DUTs through this test procedure to obtain a nominal received power value.
 - Apply a tolerance of ± 5 to 6 dB to each measurement (assuming a good setup design).
 - Make sure the measurement is made at a high enough level that it is not influenced by DUT-generated and ambient noise.
 - The Signal Generator power level can be adjusted and new limits found if the radiated test needs greater signal strength.
 - Monitor these limits during mass-production ramp-up to determine if further adjustments are needed.

Note: The value measured from the DUT is significantly influenced by the test setup and DUT design (host RF cabling loss, antenna efficiency and pattern, test antenna efficiency and pattern, and choice of shield box).

GNSS RF Receive Path Test

The GNSS receive path uses either the dedicated GNSS connector or the shared Diversity/MIMO/GNSS connector.

To test the GNSS receive path:

1. Inject a carrier signal at -110dBm, frequency 1575.52 MHz into the GNSS Rx path at the connector. (Note that this frequency is 100 kHz higher than the actual GPS L1 center frequency.)
2. Test the signal carrier-to-noise level at the GNSS receiver:
 - a. `AT+ENTERCND=<password>` (Unlock extended AT command set.)
 - b. `AT+IDAFTMACT` (Put modem into factory test mode.)
 - c. `AT+IDACGPSTESTMODE=1` (Start CGPS diagnostic task.)
 - d. `AT+IDACGPSSTANDALONE=1` (Enter standalone RF mode.)
 - e. `AT+IDACGPSMASKON` (Enable log mask.)
 - f. `AT+IDACGPSCTON` (Return signal-to-noise and frequency measurements.)
 - g. Repeat `AT+IDACGPSCTON` five to ten times to ensure the measurements are repeatable and stable.
3. Leave the RF connection to the Mini Card device intact, and turn off the signal generator.
4. Take several more `IDACGPSCTON` readings. This will demonstrate a 'bad' signal in order to set limits for testing, if needed. This frequency offset should fall outside of the guidelines in the note below, which indicates that the CtoN result is invalid.
5. (Optional) Turn the signal generator on again, and reduce the level to -120dBm. Take more `IDACGPSCTON` readings and use these as a reference for what a marginal/poor signal would be.

Note: The response to `AT+IDACGPSCTON` for a good connection should show CtoN within 58 +/- 5dB and Freq (frequency offset) within 100000 Hz +/- 5000 Hz .

Quality Assurance Testing

Note: QA is an ongoing process based on random samples from a finished batch of devices.

The quality assurance tests that you perform on your finished products should be designed to verify the performance and quality of your devices.

The following are *some* testing suggestions that can confirm that the antenna is interfaced properly, and that the RF module is calibrated and performs to specifications:

- Module registration on cellular networks
- Power consumption

- Originate and terminate data and voice (if applicable) calls
- Cell hand-off
- Transmitter and receiver tests
- FER (Frame Error Rate) as an indicator of receiver sensitivity/performance
- Channel and average power measurements to verify that the device is transmitting within product specifications
- RF sensitivity testing—BER/BLER for different bands and modes
- Transmitter and receiver tests (based on relevant sections of the 3GPP TS51010 and 3GPP 34121 documents)

Suggested Testing Equipment

To perform production and post-production tests, you will require appropriate testing equipment. A test computer can be used to coordinate testing between the integrated module (on the development kit or host) and the measurement equipment, usually with GPIB connections. The suggested setup includes a power meter to test RF output power and a signal generator to evaluate the receiver.

Testing Assistance Provided by Sierra Wireless

Extended AT commands have been implemented to assist with performing FTA GCF tests and portions of CE Mark tests requiring radio module access. These are documented in the [2] *AirPrime EM74xx/MC74xx AT Command Reference (Doc# 4117727)*.

Sierra Wireless offers optional professional services based assistance to [OEMs](#) with regulatory approvals.

IOT/Operator Testing

Interoperability and Operator/Carrier testing of the finished system is the responsibility of the [OEM](#). The test process will be determined with the chosen network operator(s) and will be dependent upon your business relationship with them, as well as the product's application and sales channel strategy.

Sierra Wireless offers assistance to OEMs with the testing process, if required.

Extended AT Commands for Testing

Sierra Wireless provides the [2] *AirPrime EM74xx/MC74xx AT Command Reference (Doc# 4117727)*, which describes proprietary AT commands that may help in hardware integration design and testing (these commands are NOT intended for use by end users).

Some commands from this document that may be useful for hardware integration are listed in [Table D-4 on page 90](#).

Table D-4: Extended AT Commands

Command	Description
Password commands	
!ENTERCND	Enable access to password-protected commands
!SETCND	Set AT command password
Modem reset and status commands	
!RESET	Reset the modem
!GSTATUS	Return the operation status of the modem (mode, band, channel, and so on)
Diagnostic commands	
!BAND	Select a set of frequency bands or reports current selection
Test commands	
!DAFTMACT	Put the modem into FTM (Factory Test Mode)
!DAFTMDEACT	Put the modem into online mode
!DALGAVGAGC	Return averaged Rx AGC value (LTE)
!DALGRXAGC	Return Rx AGC value (LTE)
!DALGTXAGC	Return Tx AGC value and transmitter parameters (LTE)
!DAOFFLINE	Place modem offline
!DASBAND	Set the frequency band (UMTS/GSM)
!DASCHAN	Set the modem channel (frequency) (UMTS/GSM)
!DASLNAGAIN	Set the LNA (Low Noise Amplifier) gain state
!DASPDM	Set the PDM (Pulse Duration Modulation) value
!DASTXOFF	Turn off the Tx PA (Power Amplifier)
!DASTXON	Turn on the Tx PA (Power Amplifier)
!DAWGAVGAGC	Return averaged RX AGC value (WCDMA)
!DAWGRXAGC	Return the Rx AGC (Automatic Gain Control) value (UMTS)
!DAWINFO	Return WCDMA mode RF information

Table D-4: Extended AT Commands

Command	Description
!DAWSCONFIGRX	Set the UMTS receiver to factory calibration settings
!DAWSPARANGE	Set the PA range state machine (UMTS)
!DAWSCHAINTCM	Place receive chain in test call mode (WCDMA)
!DAWSSCHAIN	Enable secondary receive chain (WCDMA)
!DAWSTXCW	Set the waveform used by the transmitter (UMTS)
!DAWSTXPWR	Set desired Tx power level (WCDMA)

»» E: Packaging

Sierra Wireless AirPrime Mini Cards are shipped in sealed boxes. The standard packaging (see [Figure 5-1](#)), contains a single tray with a capacity of 100 modules. (Note that some SKUs may have custom packaging—contact Sierra Wireless for SKU-specific details.)

In the standard packaging, Mini Cards are inserted, system connector first, into the bottom portion (T1) of a two-part tray. All facing the same direction. This allows the top edge of each Mini Card to contact the top of the triangular features in the top portion (T2) of the tray (see Detail A).

The top and bottom portions of the tray snap together at the four connection points.

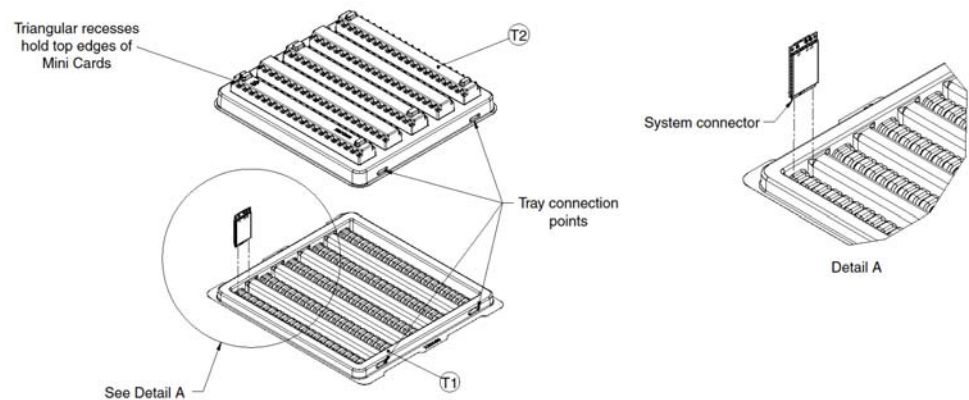

Figure 5-1: Device Placement in Module Tray

The tray is placed in a manufacturing box (T2 at the top), sealed with a security tape (P1), and a manufacturing label is placed on the bottom-right corner, above the security tape. (See [Figure 5-2](#).)

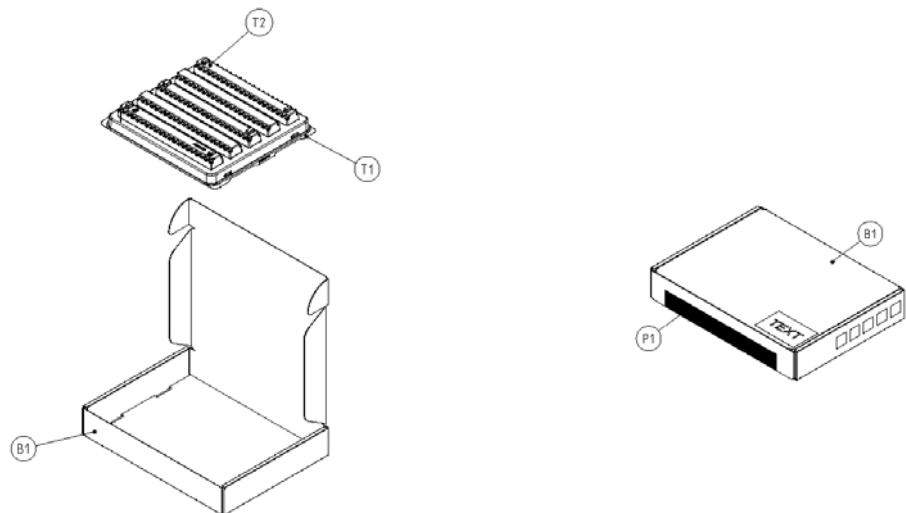

Figure 5-2: Shipping Package

»» | F: References

F

This guide deals specifically with hardware integration issues that are unique to AirPrime embedded modules.

Sierra Wireless Documents

The Sierra Wireless documents listed below are available from www.sierrawireless.com. For additional documents describing embedded module design, usage, and integration issues, contact your Sierra Wireless account representative.

Command Documents

- [1] AT Command Set for User Equipment (UE) (Release 6)
(Doc# 3GPP TS 27.007)
- [2] AirPrime EM74xx/MC74xx AT Command Reference
(Doc# 4117727)

Other Sierra Documents

- [3] PCI Express Mini Card Dev Kit Quick Start Guide
(Doc# 2130705)
- [4] AirCard/AirPrime USB Driver Developer's Guide (Doc# 2130634)

Industry/Other Documents

The following non-Sierra Wireless references are not included in your documentation package:

- [5] FCC Regulations - Part 15 - Radio Frequency Devices
- [6] IEC-61000-4-2 level 3
- [7] IEC-61000-4-2 level (Electrostatic Discharge Immunity Test)
- [8] Mobile Station (MS) Conformance Specification; Part 4:
Subscriber Interface Module (Doc# 3GPP TS 11.10-4)
- [9] PCI Express Mini Card Electromechanical Specification Revision
2.1
- [10] Universal Serial Bus Specification, Rev 2.0
- [11] Universal Serial Bus Specification, Rev 3.0
- [12] JESD22-A114-B
- [13] JESD22-C101

»» G: Acronyms

Table G-1: Acronyms and Definitions

Acronym or term	Definition
3GPP	3rd Generation Partnership Project
8PSK	Octagonal Phase Shift Keying
AGC	Automatic Gain Control
A-GPS	Assisted GPS
API	Application Programming Interface
BeiDou	BeiDou Navigation Satellite System A Chinese system that uses a series of satellites in geostationary and middle earth orbits to provide navigational data.
BER	Bit Error Rate—A measure of receive sensitivity
BLER	Block Error Rate
bluetooth	Wireless protocol for data exchange over short distances
CQI	Channel Quality Indication
COM	Communication port
CS	Circuit-switched
CSG	Closed Subscriber Group
CW	Continuous waveform
dB	Decibel = $10 \times \log_{10} (P1/P2)$ <i>P1 is calculated power; P2 is reference power</i> Decibel = $20 \times \log_{10} (V1/V2)$ <i>V1 is calculated voltage, V2 is reference voltage</i>
dBm	A logarithmic (base 10) measure of relative power (dB for decibels); relative to milliwatts (m). A dBm value will be 30 units (1000 times) larger (less negative) than a dBW value, because of the difference in scale (milliwatts vs. watts).
DC-HSPA+	Dual Carrier HSPA+
DCS	Digital Cellular System A cellular communication infrastructure that uses the 1.8 GHz radio spectrum.
DL	Downlink (network to mobile)
DRX	Discontinuous Reception
DSM	Distributed Shared Memory
DUT	Device Under Test
eICIC	Enhanced Inter-Cell Interference Coordination

Table G-1: Acronyms and Definitions (Continued)

Acronym or term	Definition
EIRP	Effective (or Equivalent) Isotropic Radiated Power
EMC	Electromagnetic Compatibility
EMI	Electromagnetic Interference
ERP	Effective Radiated Power
ESD	Electrostatic Discharge
FCC	Federal Communications Commission The U.S. federal agency that is responsible for interstate and foreign communications. The FCC regulates commercial and private radio spectrum management, sets rates for communications services, determines standards for equipment, and controls broadcast licensing. Consult www.fcc.gov .
FDD	Frequency Division Duplexing
FDMA	Frequency Division Multiple Access
feICIC	Further Enhanced Inter-Cell Interference Coordination
FER	Frame Error Rate—A measure of receive sensitivity.
firmware	Software stored in ROM or EEPROM; essential programs that remain even when the system is turned off. Firmware is easier to change than hardware but more permanent than software stored on disk.
FOTA	Firmware Over The Air—Technology used to download firmware upgrades directly from the service provider, over the air.
FOV	Field Of View
FSN	Factory Serial Number—A unique serial number assigned to the mini card during manufacturing.
Galileo	A European system that uses a series of satellites in middle earth orbit to provide navigational data.
GCF	Global Certification Forum
GLONASS	Global Navigation Satellite System—A Russian system that uses a series of 24 satellites in middle circular orbit to provide navigational data.
GMSK	Gaussian Minimum Shift Keying modulation
GNSS	Global Navigation Satellite Systems (GPS, GLONASS, BeiDou, and Galileo)
GPS	Global Positioning System An American system that uses a series of 24 satellites in middle circular orbit to provide navigational data.
Host	The device into which an embedded module is integrated
HSDPA	High Speed Downlink Packet Access
HSPA+	Enhanced HSPA, as defined in 3GPP Release 7 and beyond
HSUPA	High Speed Uplink Packet Access

Table G-1: Acronyms and Definitions (Continued)

Acronym or term	Definition
Hz	Hertz = 1 cycle/second
IC	Industry Canada
IF	Intermediate Frequency
IMEI	International Mobile Equipment Identity
IMS	IP Multimedia Subsystem—Architectural framework for delivering IP multimedia services.
inrush current	Peak current drawn when a device is connected or powered on
inter-RAT	Radio Access Technology
IOT	Interoperability Testing
IS	Interim Standard. After receiving industry consensus, the TIA forwards the standard to ANSI for approval.
LED	Light Emitting Diode. A semiconductor diode that emits visible or infrared light.
LHCP	Left-Hand Circular Polarized
LNA	Low Noise Amplifier
LPM	Low Power Mode
LPT	Line Print Terminal
LTE	Long Term Evolution—a high-performance air interface for cellular mobile communication systems.
MCS	Modulation and Coding Scheme
MHz	Megahertz = 10e6 Hz
MIMO	Multiple Input Multiple Output—wireless antenna technology that uses multiple antennas at both transmitter and receiver side. This improves performance.
NAS/AS	Network Access Server
NC	No Connect
NIC	Network Interface Card
NLIC	Non-Linear Interference Cancellation
NMEA	National Marine Electronics Association
OEM	Original Equipment Manufacturer—a company that manufactures a product and sells it to a reseller.
OFDMA	Orthogonal Frequency Division Multiple Access
OMA DM	Open Mobile Alliance Device Management—A device management protocol.

Table G-1: Acronyms and Definitions (Continued)

Acronym or term	Definition
OTA	'Over the air' (or radiated through the antenna)
PA	Power Amplifier
packet	A short, fixed-length block of data, including a header, that is transmitted as a unit in a communications network.
PCB	Printed Circuit Board
PCS	Personal Communication System A cellular communication infrastructure that uses the 1.9 GHz radio spectrum.
PDN	Packet Data Network
PMI	Pre-coding Matrix Index
PSS	Primary synchronisation signal
PST	Product Support Tools
PTCRB	PCS Type Certification Review Board
QAM	Quadrature Amplitude Modulation. This form of modulation uses amplitude, frequency, and phase to transfer data on the carrier wave.
QMI	Qualcomm MSM/Modem Interface
QOS	Quality of Service
QPSK	Quadrature Phase-Shift Keying
QPST	Qualcomm Product Support Tools
RAT	Radio Access Technology
RF	Radio Frequency
RI	Ring Indicator
roaming	A cellular subscriber is in an area where service is obtained from a cellular service provider that is not the subscriber's provider.
RSE	Radiated Spurious Emissions
RSSI	Received Signal Strength Indication
SDK	Software Development Kit
SED	Smart Error Detection
Sensitivity (Audio)	Measure of lowest power signal that the receiver can measure.
Sensitivity (RF)	Measure of lowest power signal at the receiver input that can provide a prescribed BER/BLER/SNR value at the receiver output.
SG	An LTE signaling interface for SMS ("SMS over SGs")

Table G-1: Acronyms and Definitions (Continued)

Acronym or term	Definition
SIB	System Information Block
SIM	Subscriber Identity Module. Also referred to as USIM or UICC.
SIMO	Single Input Multiple Output—smart antenna technology that uses a single antenna at the transmitter side and multiple antennas at the receiver side. This improves performance and security.
SISO	Single Input Single Output—antenna technology that uses a single antenna at both the transmitter side and the receiver side.
SKU	Stock Keeping Unit—identifies an inventory item: a unique code, consisting of numbers or letters and numbers, assigned to a product by a retailer for purposes of identification and inventory control.
SMS	Short Message Service. A feature that allows users of a wireless device on a wireless network to receive or transmit short electronic alphanumeric messages (up to 160 characters, depending on the service provider).
S/N	Signal-to-noise (ratio)
SNR	Signal-to-Noise Ratio
SOF	Start of Frame—A USB function.
SSS	Secondary synchronisation signal.
SUPL	Secure User Plane Location
TDD	Time Division Duplexing
TIA/EIA	Telecommunications Industry Association / Electronics Industry Association. A standards setting trade organization, whose members provide communications and information technology products, systems, distribution services and professional services in the United States and around the world. Consult www.tiaonline.org .
TIS	Total Isotropic Sensitivity
TRP	Total Radiated Power
UDK	Universal Development Kit (for PCI Express Mini Cards)
UE	User Equipment
UICC	Universal Integrated Circuit Card (Also referred to as a SIM card.)
UL	Uplink (mobile to network)
UMTS	Universal Mobile Telecommunications System
USB	Universal Serial Bus
USIM	Universal Subscriber Identity Module (UMTS)
VCC	Supply voltage
VSWR	Voltage Standing Wave Ratio

Table G-1: Acronyms and Definitions (Continued)

Acronym or term	Definition
WAN	Wide Area Network
WCDMA	Wideband Code Division Multiple Access (also referred to as UMTS)
WLAN	Wireless Local Area Network
ZIF	Zero Intermediate Frequency
ZUC	ZUC stream cypher

Index

Numerics

- 3D gain, average gain
 - 3D average (GNSS), 74
- 3GPP compliance
 - LTE, 21
 - UMTS, 21

A

- acceptance tests, 77
- accessories, 19
- accuracy (GNSS), 45
- acquisition time (GNSS), 45
- acronyms and definitions, 97–102
- A-GNSS, 18
- A-GPS, 18
- antenna
 - connection considerations, 37
 - connectors, 23
 - custom, design, 38
 - diversity antenna, disabling, 38
 - GNSS, specifications, recommended, 73
 - limit, matching coaxial connections, 37
 - location, considerations, 38
 - matching, considerations, 38
 - maximum cable loss, 37
 - routing, 38
 - specification, 67–74, 71–74
 - specifications, recommended, 71
 - testing, 74
- antennas
 - design checklist, 75
- API, 55
- application interface features, 16
- approvals, regulatory and industry, 63
- AT commands, 90
- averaged call mode DC power consumption, 48
- averaged standby DC power consumption, 47

B

- bands supported, RF
 - summary, 15
 - LTE, 41, 42, 82, 84, 86
- bearers, dedicated, 18
- BER (Bit Error Rate), 41
- bit error rate (BER)
 - measure of sensitivity, 41
- block diagram
 - expanded RF, 25
 - system, 24
- bottom view, 58

C

- cable loss
 - antenna, maximum, 37
- capacitors
 - with SIM, 33
 - with XIM_DATA / XIM_CLK, 33
- carrier/operator testing, 89
- cell selection, 17
- certification tests, 78
- checklist, design, 75
- communications, host to modem
 - design checklist, 76
- conducted Tx power tolerances, 44
- connection
 - grounding, 39
- connectors, 37
- connectors, required
 - host-module, 19
- control interface, 34
- CQI, 18

D

- DC power consumption
 - averaged call mode, 48
 - averaged standby, 47
- desense. See RF
- design checklist
 - antennas, 75
 - component placement, 75
 - EMI/ESD, 76
 - host/modem communications, 76
 - power, 75
 - thermal, 76
 - USB3, 75
- detach procedure, 18
- Development Kit contents, 19
- digital interface, 36
- dimensioned view, 58
- dimensions, 57, 58
- diversity antenna
 - disabling, 38
- diversity connector, location, 37
- drop specifications, 57

E

- EDGE
 - connector, required, 19
- electrical specifications, 23
- electrostatic discharge specifications, 57
- electrostatic discharge. See ESD
- envelope correlation coefficient, 72

environmental specifications, [57–59](#)

ESD

- [design checklist, 76](#)
- [protection requirements, 59](#)

ESD specifications, [57](#)

expanded RF block diagram, [25](#)

F

field of view, [73](#)

filtering, RF desense, [40](#)

form factor, [57](#)

FOV, [73](#)

free space average gain, [74](#)

frequencies supported, [41](#)

frequency band support

- [LTE, 41, 42, 82, 84, 86](#)

G

gain

- [GNSS, 74](#)
- [maximum, 64, 72](#)
- [mean effective, 72](#)
- [mean effective imbalance, 72](#)

GNSS

- [antenna specifications, recommended, 73](#)
- [connector location, 37](#)
- [features supported, 18](#)
- [specifications, 44](#)

gpsOneXTRA, [18](#)

ground specifications, [30](#)

grounding

- [connection considerations, 39](#)

H

host interface

- [pin assignments, 25](#)

humidity specifications, [57](#)

I

I/O connector location, [37](#)

I/O rise time requirements, [33](#)

impedance

- [module–antenna, 38](#)
- [SIM, 33](#)

industry approvals, [63](#)

integration requirements, [19](#)

interface

- [control interface, 34](#)
- [digital interface, 36](#)
- [feature summary, 16](#)
- [host, pin assignments, 25](#)
- [QMI, 55](#)
- [SIM, 31](#)
- [software, 55](#)
- [USB, 30](#)

interference

- [device generated, 40](#)
- [host-generated, 39](#)
- [power supply noise, 52](#)
- [wireless devices, 39](#)

Interoperability testing, [89](#)

intra-LTE mobility, [18](#)

IOT testing, [89](#)

iRAT, [18](#)

isolation, [73, 74](#)

L

labeling, [59](#)

LED

- [example, 35](#)

LED output, [23, 34, 35](#)

LTE

- [3GPP compliance, 21](#)
- [features, 17](#)
- [frequency band support, 41, 42, 82, 84, 86](#)

M

mean effective gain, [72](#)

mean effective gain imbalance, [72](#)

mechanical specifications, [57–59](#)

MIB, [17](#)

minicom

- [downloading and installing, 82](#)

module

- [power states, 49–51](#)

N

NAS/AS security, [17](#)

noise

- [leakage, minimizing, 39](#)
- [RF interference, power supply, 52](#)

O

OEM

- [assistance with testing, 89](#)
- [labeling, 59](#)

operator/carrier testing, [89](#)

ordering information, [19](#)

P

- packaging, 93
- paging procedures, 18
- PCB
 - multi-layer, shielding for RF desense, 40
- PDN connections, multiple, 18
- pin assignments, host interface, 25
- PMI, 18
- polarization, 74
- position location, 18
- power
 - design checklist, 75
 - handling, 73
 - power-up timing, 51
 - ramp-up timing, 51
 - state machines, 50
 - states, module, 49–51
 - supply, RF interference, 52
 - supply, ripple limit, 52
- power consumption, DC
 - averaged call mode, 48
 - averaged standby, 47
- power specifications, 30
- power tolerances, conducted Tx, 44
- Product Support Tool, QUALCOMM (QPST), 55
- production tests, 79
- PSS, 17

Q

- QMI interface, 55
- QPST (QUALCOMM Product Support Tool), 55
- QUALCOMM Product Support Tool (QPST), 55
- quality assurance tests, 88
- QXDM support, 55

R

- radiated efficiency, total, 72
- radiated sensitivity measurement, 40
- radiated spurious emissions, 40
- radiation patterns, 72
- references, 95
- regulatory approvals, 63
- regulatory information, 63–66
 - FCC, 64
 - limitation of liability, 63
 - safety and hazards, 64
- reset device, 36
- resistors, external pull-up, 33

RF

- antenna cable loss, maximum, 37
- antenna connection, considerations, 37
- connectors, required, 19
- desense
 - device-generated, 39
 - harmonic energy, filtering, 40
 - mitigation suggestions, 40
 - shielding suggestions, 40
- interference
 - other devices, 40
 - power supply, 52
 - wireless devices, 39
- RF bands supported
 - summary, 15
 - LTE, 41, 42, 82, 84, 86
- RF block diagram, expanded, 25
- RF connector location, 37
- RF specifications, 37–45
- RI, 18
- RSE, 40
- Rx sensitivity
 - conducted, 43, 44

S

- sales
 - ordering, 19
- SDKs available, 55
- SED
 - see Smart Error Detection
- See also W_DISABLE_N, 35
- sensitivity
 - conducted, RF parameter, 43, 44
 - defined, 41
 - radiated measurement, overview, 40
 - testing, overview, 41
- shielding
 - module, compliance, 37
 - reducing RF desense, 40
- shock specifications, 57
- SIB, 17
- signals, 34
 - SYSTEM_RESET_N, 36
 - W_DISABLE_N, 35
 - WAKE_N, 34
 - WLAN_LED_N, 35
- SIM
 - capacitor recommendations, 33
 - card contacts, 32
 - clock rate, 33
 - connector, required, 19
 - electrical specifications, 33
 - impedance, connectors, 33
 - interface, 31
 - interface diagram, 32
 - operation, 33
- Smart Error Detection
 - detecting module reset, 52

- SMS features, [18](#)
- Snow 3G/AES security, [17](#)
- software interface, [55](#)
- specifications
 - electrical, [23](#)
 - environmental specifications, [57–59](#)
 - GNSS, [44](#)
 - mechanical, [57–59](#)
 - RF, [37–45](#)
- SSS, [17](#)
- standalone mode, concurrent, GNSS, [18](#)
- standalone mode, GPS/GLONASS, [18](#)
- standby DC power consumption, averaged, [47](#)
- state machines, [50](#)
- support
 - testing assistance by Sierra Wireless, [89](#)
 - tools, [55](#)
- system acquisition, [17](#)
- system block diagram, [24](#)
- SYSTEM_RESET_N, [36](#)

T

- temperature specifications, [57](#)
- temperature, module. See thermal
- testing
 - overview, [77](#)
 - acceptance tests, [77](#)
 - assistance provided by Sierra Wireless, [89](#)
 - certification tests, [78](#)
 - equipment, suggested, [89](#)
 - interoperability and operator/carrier testing, [89](#)
 - manual functional test, suggested, [79](#)
 - production tests, [79](#)
 - quality assurance tests, [88](#)
 - RF receive path, LTE, [86](#)
 - suggestions, [77–91](#)
- thermal
 - considerations, [60–61](#)
 - design checklist, [76](#)
 - dissipation, factors affecting, [60](#)
 - dissipation, suggestions, [60](#)
 - internal temperature, maximum, [61](#)
 - testing, module, [61](#)

- timing
 - power ramp-up, [51](#)
 - power-up, [51](#)
- top view, [58](#)
- tracking session
 - automatic, [18](#)
 - standalone, [18](#)
- Tx power tolerances, conducted, [44](#)

U

- UDK, [19](#)
- UMTS
 - 3GPP compliance, [21](#)
- Universal Development Kit, [19](#)
- USB
 - drivers, user-developed, [31](#)
 - high / full speed throughput performance, [31](#)
 - interface, [30](#)
- USB3
 - design checklist, [75](#)

V

- vibration specifications, [57](#)
- VSWR, [71, 74](#)

W

- W_DISABLE_N, [34, 35](#)
- WAKE_N, [23, 34](#)
- Wireless Disable, [23](#)
- Wireless Disable (Main RF), [35](#)
- WLAN_LED_N, [34, 35](#)

Z

- ZIF (Zero Intermediate Frequency), [39](#)



SIERRA
WIRELESS®