

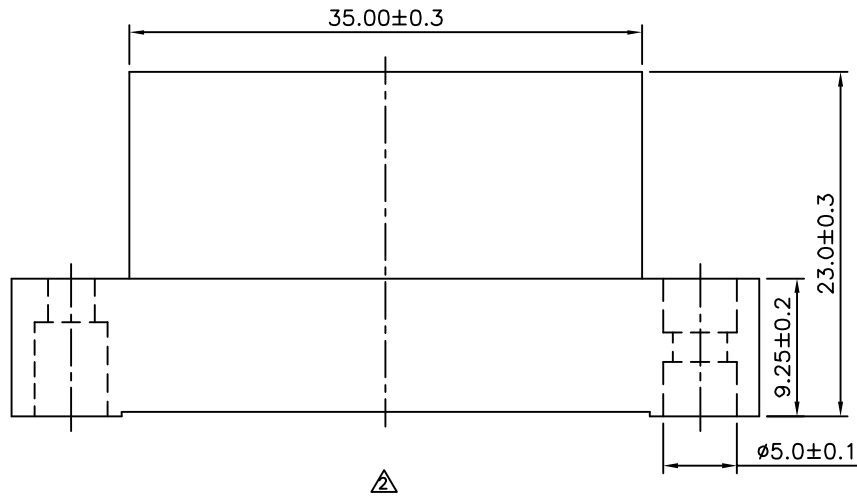

SPECIFICATION
 Contact Current Rating:7 Amp
 Dielectric Withstand Voltage:1200V AC
 Contact Resistance:10 Milliohms Max.
 Insulation Resistance:>1000 Megaohms Min.
 Operation Temperature Range:-55°C~+105°C
 Housing:PBT(UL94V-0),Black
 RoHS Compliant

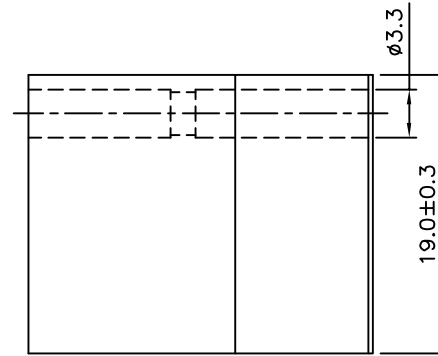
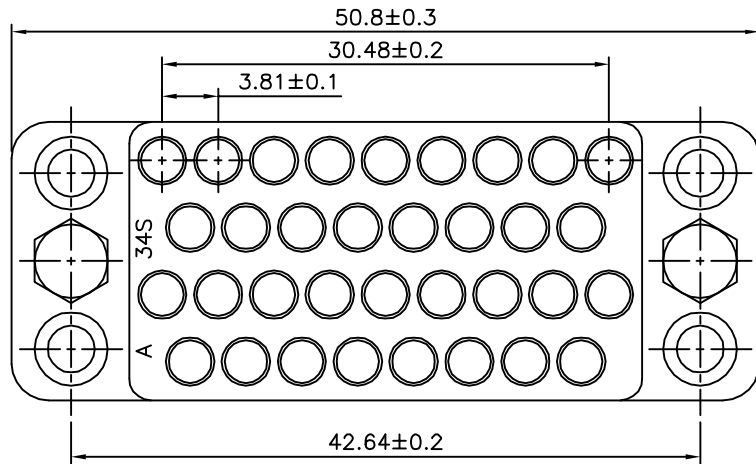

M34 SH W - XX - H
 (1) (2) (3) (4) (5)

- (1) M34:V.35 34 Pin Crimp Type
- (2) SH:Female Housing
- (3) W:Silver Color Aluminum Hood Screw Accessories
- (4) XX:Entry Hole Position
Blank:Entry Hole=ø9
12:Entry Hole=ø12
- (5) H:RoHS Compliant

AUK A MEMBER OF AUK GROUP
太聯事業股份有限公司
AUK CONTRACTORS CO., LTD.

CATEGORY		APPROVED BY MEI		UNLESS OTHERWISE SPECIFIED TOLERANCES ARE .X ±0.38 .XX ±0.25 ANG.				
PART No. M34SHW-XX-H		CHECKED BY HZF			△ A3	Modify P/N: M34SHW-H --> M34SHW-XX-H	HZF	12/01/2011
DRAWING No. M34SHW-XX-H		DRAWING BY WSS			△ A2	Modify Data	HZF	08/12/2011
SCALE	NONE	REV.	A3		△ A1	Add Specifications	SHIN	09/07/2006
				UNIT mm	NO. REV.		REVISIONS	CHK DATE
						△ A0	NEW RELEASE	MEI 06/12/2001

△ SPECIFICATION
 Back Shell: Aluminum Alloy, Nickel Plated Over Copper
 Jackscrews: Steel, Nickel Plated Over Copper
 Thread Screw: Steel, Nickel Plated Over Copper
 Flat Screw: Steel, Nickel Plated Over Copper
 Cable Clipper: ABS, Black
 RoHS Compliant

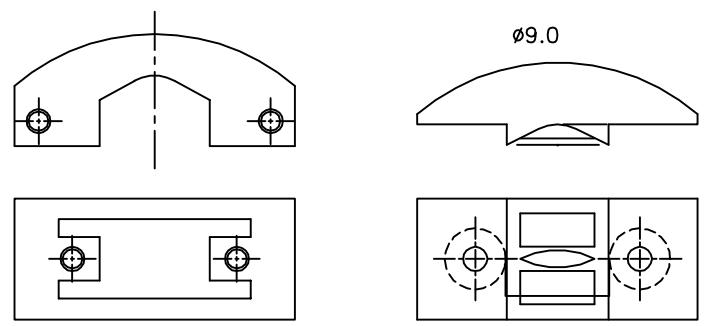

Cable Clipper

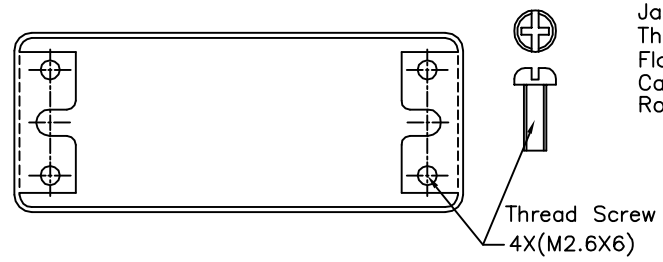

Thread Screw
4X(M2.6X6)

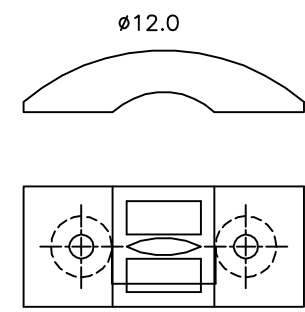

△ Cable Clipper

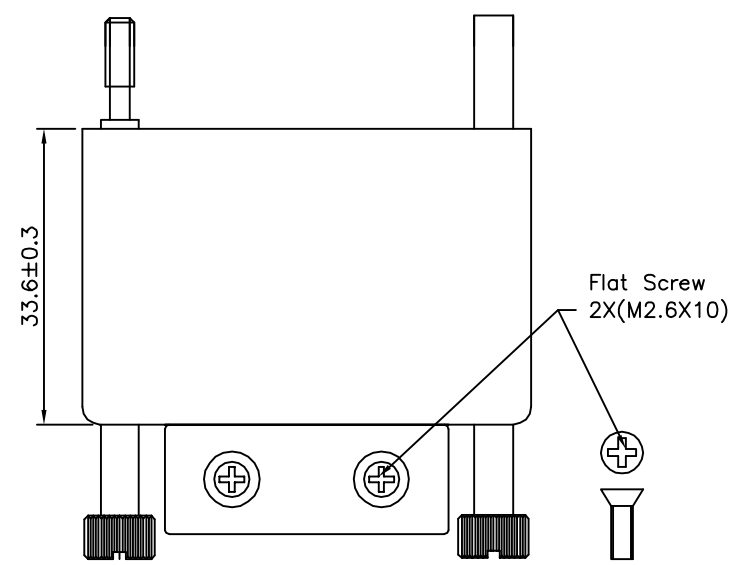
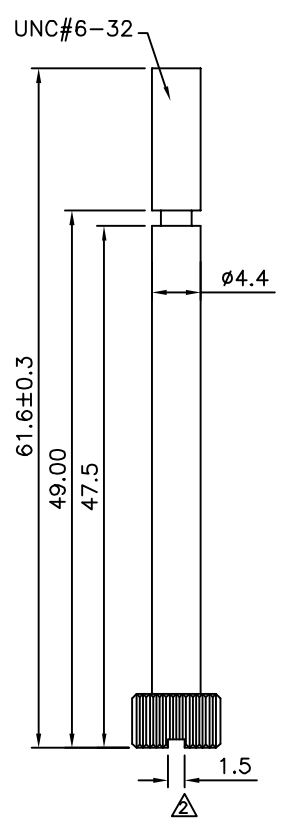
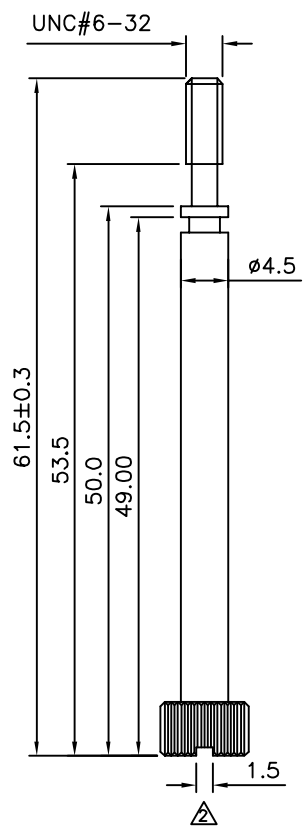

Flat Screw
2X(M2.6X10)

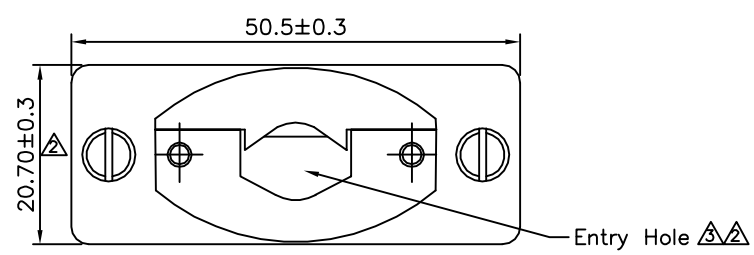

Entry Hole △△

AUK A MEMBER OF AUK GROUP
太聯事業股份有限公司
AUK CONTRACTORS CO., LTD.

CATEGORY		APPROVED BY		UNLESS OTHERWISE SPECIFIED TOLERANCES ARE △ .X ±0.38 .XX ±0.25 ANG.				
PART No. △ M34SHW-XX-H		MEI			△ A3	Modify P/N: M34SHW-H --> M34SHW-XX-H	HZF	12/01/2011
DRAWING No. M34SHW-XX-H		HZF			△ A2	Modify Data	HZF	08/12/2011
SCALE NONE		WSS			△ A1	Add Specifications	SHIN	09/07/2006
REV.	A3	UNIT mm	△	△ A0	NEW RELEASE	MEI	06/12/2001	
				NO.REV.	REVISIONS	CHK	DATE	