



ISO9001 & ISO14001 & TS16949 CHILISIN ELECTRONICS CORP.

Lead-Free & RoHs Compliance!!

SPECIFICATION FOR APPROVAL

CUSTOMER :

CUSTOMER P/N :

OUR DWG No :

QUANTITY : 0 Pcs. DATE : 2013/07/11

ITEM : LVF303010-SERIES

SPECIFICATION ACCEPTED BY:	
COMPONENT ENGINEER	
ELECTRICAL ENGINEER	
MECHANICAL ENGINEER	
APPROVED	
REJECTED	

<p>奇力新電子股份有限公司 CHILISIN ELECTRONICS CORP. NO.29,LANE 301,TEHHSIN ROAD,HUKOU, HSINCHU,TAIWAN,303, REPUBLIC OF CHINA TEL : (03) 599-2646 FAX : (03) 599-9176 E-mail : Sales@chilisin.com.tw http : //www.chilisin.com.tw</p> <p>台北營業處 Taipei Office 1F., No.2, Aly. 1, Ln. 235, Baoqiao Rd., Xindian Dist., New Taipei City 231, Taiwan TEL : +886-2-6629-5588~9 FAX : +886-2-6629-0088 E-mail : Sales@chilisin.com.tw</p>	<p>東莞奇力新電子有限公司 Chilisin Electronics (Dongguan) Co., Ltd. No. 78, Puxing Rd., Yuliangwei Administration Area, Qingxi Town, Dongguan City, Guangdong,China TEL : +86-769-8773-0251~3 FAX : +86-769-8773-0232 E-mail : cect@chilisin.com.tw</p> <p>奇力新電子(蘇州)有限公司 Chilisin Electronics (Suzhou) Co., Ltd. No.143,Song Shan Rd., Suzhou New District, Suzhou,China Postal Code:215129 TEL:+86-512-6841-2350 FAX:+86-512-6841-2356 E-mail : suzhou@chilisin.com.tw</p>
-----------------------------------------------------------------------------------------------------------------------------------------------------------------------------------------------------------------------------------------------------------------------------------------------------------------------------------------------------------------------------------------------------------------------------------------------------------------------------------------	----------------------------------------------------------------------------------------------------------------------------------------------------------------------------------------------------------------------------------------------------------------------------------------------------------------------------------------------------------------------------------------------------------------------------------------------------------------------------------------------------------------------

DRAWN BY 黃瓊慧 joanne.huang	CHECKED BY 溫美玲 ling	APPROVED BY 陳瑞揚 ryan.chen
------------------------------	------------------------	------------------------------

LVF303010 Series Specification

1 Scope: This specification applies to Wire Wound Power Inductors

2 Part Numbering: Product Identification

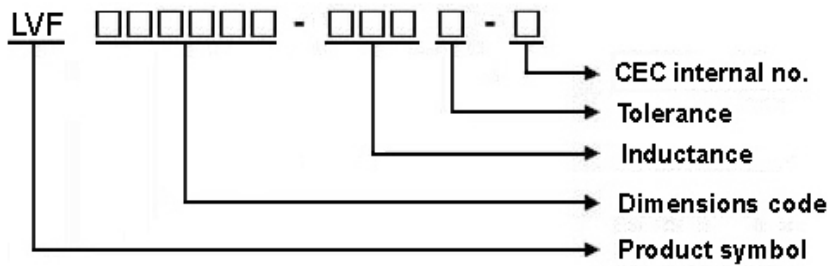

3 Rating:

Operating Temperature: $-5.5^{\circ}\text{C} \sim 125^{\circ}\text{C}$ (Including self - temperature rise)

Storage Temperature: $20^{\circ}\text{C} \sim 25^{\circ}\text{C}$ R.H. 65% (For Reference)

4 Marking:

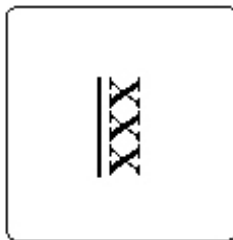

Ex : LVF303010-6R8M-N

Marking : 6R8

Marking color : Black

5 Standard Testing Condition

	Unless otherwise specified	In case of doubt
Temperature	Ordinary Temperature(15 to 35°C)	20±2°C
Humidity	Ordinary Humidity(25 to 85% RH)	60 to 70 % RH

LVF303010 Series Specification

6 Configuration and Dimensions:

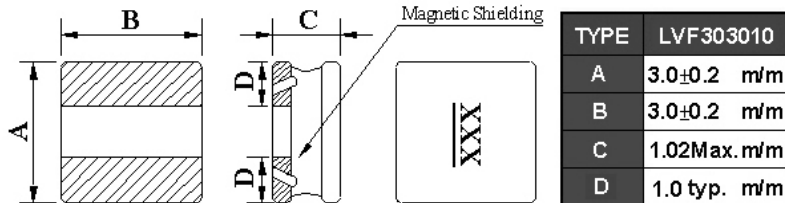

7 ELECTRICAL CHARACTERISTICS :

Part No.	Inductance (uH)	Test Freq.	RDC (Ω)±30%	Isat(mA) Typ.(Max)	Irms(mA) Typ.(Max)	Tolerance (±%)	Marking
LVF303010-1R5□-N	1.5	1MHz,200mV	0.085	1800(1620)	1700(1530)	20,30	1R5
LVF303010-2R2□-N	2.2	1MHz,200mV	0.1	1500(1350)	1400(1260)	20,30	2R2
LVF303010-4R7□-N	4.7	1MHz,200mV	0.205	1000(900)	950(850)	20,30	4R7
LVF303010-6R8□-N	6.8	1MHz,200mV	0.31	870(780)	850(760)	20,30	6R8
LVF303010-100□-N	10	1MHz,200mV	0.43	640(570)	630(560)	20,30	100
LVF303010-150□-N	15	1MHz,200mV	0.625	560(500)	550(490)	20,30	150
LVF303010-220□-N	22	1MHz,200mV	0.87	470(420)	460(410)	20,30	220

NOTE: □-tolerance M=±20% / T=±30%

1. Operating temperature range - 5 5°C ~ 1 2 5°C (Including self - temperature rise)

2. Isat for Inductance drop 30% from its value without current.

3. I rms for a 40°C rise above 25°C ambient.

"-N" FOR COMPLETELY LEAD FREE TYPE (INCLUDING FERRITE BODY & SOLDER)

LVF303010 Series Specification

8 L VF303010 Series

8.1 Construction:

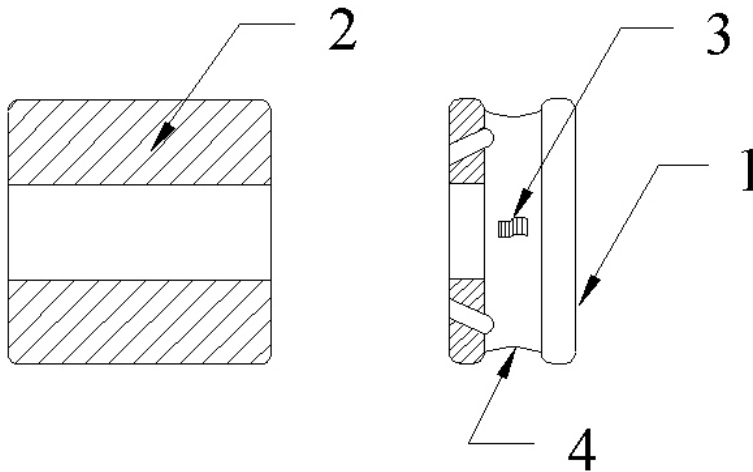

8.2 Material List:

ITEM	PART	DESCRIPTION	SUPPLIES
1	CORE	FERRITE	CHILISIN
2	TERMINAL	Ag/Ni/Sn	
3	WIRE	Grade 180	ELEKTRISOLA
4	EPOXY	Magnetic powder resin	

LVF303010 Series Specification

9 Reliability Of Wire Wound Power Inductors

1-1.Mechanical Performance

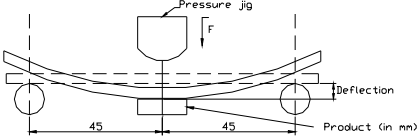
	Item	Specification	Test Method
1-1-1	Bending Test	Chip coil shall not be damaged after tested as test method	Substrate:Glass-epoxy substrate(100mm*40mm*1.6mm) speed of Applying Force:1mm/s Deflection:2mm Hold Duration:30s <div style="text-align: center;">  </div>
1-1-2	Vibration		Oscillation Frequency:10Hz to 55 Hz to 10 hZ for 1 min Total Amplitude:1.5mm Testing Time:A period of 2 hours in each of 3 mutually perpendicular directions(Total 6 hours)
1-1-3	Solderability	The wetting area of the electrode shall be at least 95% covered with new solder coating	Solder:Sn/Ag3.0/Cu0.5 per-Heating:150°C±10°C/1min to 2min solder Temperature:245°C±5°C Immersion Time:4s±1s
1-1-4	Resistance to Soldering Heat	Appearance:No damage	Solder:Sn/Ag3.0/Cu0.5 per-Heating:150°C±10°C/1min to 2min solder Temperature:260°C±5°C Immersion Time:10s±1s
1-1-5	Resistance to solvent	There must be no change in appearance or obliteration of marking.	Inductors must withstand 6 minutes of alcohol or water.

1-2.Environmental Performance

No	Item	Specification	Test Method															
1-2-1	Heat Resistance	Appearance: No damage Inductance Change:within±10%	Temperature:125°C±3°C Time:500h Then measured after exposure in the room Condition for 24h±2h															
1-2-2	Cold Resistance		Temperature: -55°C±3°C Time:500h Then measured after exposure in the room Condition for 24h±2h															
1-2-3	Humidity		Temperature: 40°C±2°C Humidity:90%(RH) to 95%(RH) Time:500h Then measures after exposure in the room Condition for 24h±2h															
1-2-4	Temperature Cycle		One cycle: <table border="1" style="width: 100%; border-collapse: collapse; margin-top: 5px;"> <thead> <tr> <th style="width: 10%;">Step</th> <th style="width: 40%;">Temperature (°C)</th> <th style="width: 50%;">Time (min)</th> </tr> </thead> <tbody> <tr> <td>1</td> <td>-55±3</td> <td>30</td> </tr> <tr> <td>2</td> <td>25±2</td> <td>3</td> </tr> <tr> <td>3</td> <td>125±3</td> <td>30</td> </tr> <tr> <td>4</td> <td>25±2</td> <td>3</td> </tr> </tbody> </table> Total: 100cycles Measured after exposure in the room condition for 24hrs	Step	Temperature (°C)	Time (min)	1	-55±3	30	2	25±2	3	3	125±3	30	4	25±2	3
Step	Temperature (°C)	Time (min)																
1	-55±3	30																
2	25±2	3																
3	125±3	30																
4	25±2	3																

LVF303010 Series Specification

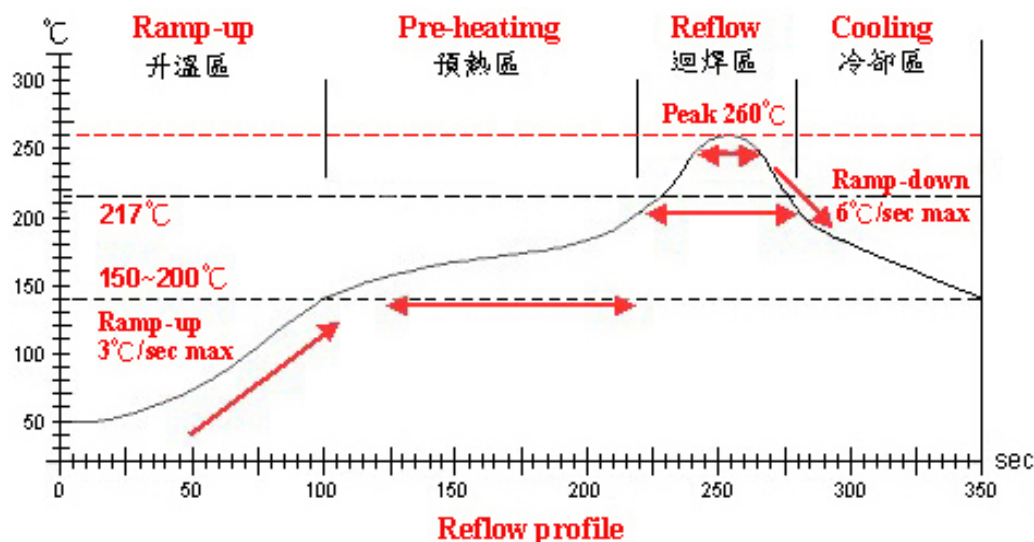

Lead-Free(LF) 標準溫度分析範圍

Refer to J-STD-020C

管制項目 Item.	升温區 Ramp-up	預熱區 Pre-heating	迴焊區 Reflow	Peak Temp	冷卻區 Cooling
溫度範圍 Temp.scope	R.T. ~ 150°C	150°C ~ 200°C	217°C	260±5°C	Peak Temp. ~ 150°C
標準時間 Time spec.	—	60 ~ 180 sec	60 ~ 150sec	20 ~ 40 sec	—
實際時間 Time result	—	75 ~ 100 sec	90 ~ 120sec	5 ~ 10 sec	—

NOTE :

1. Re-flow possible times : within 2 times
2. Nitrogen adopted is recommended while in re-flow

LVF303010 Series Specification

11 PACKAGING

11.1 Packaging -Cover tape

The force for tearing off cover tape is 10 to 100 grams in the arrow direction.

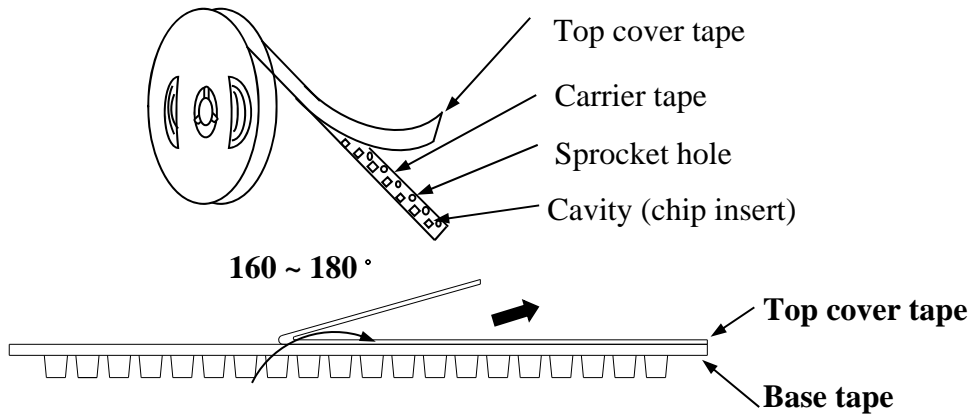

11.2 Packaging Quantity

TYPE	BULK	PCS/REEL
LVF303010	✓	2000

11.3 Reel Dimensions

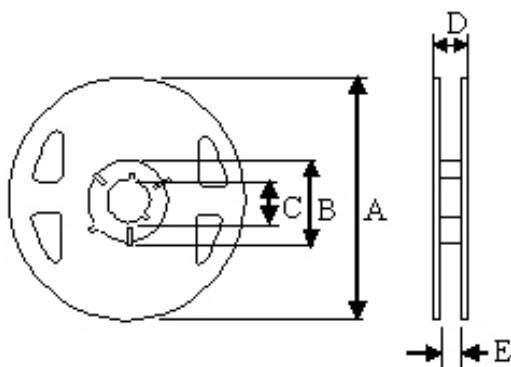

Dimensions in mm

TYPE	A	B	C	D	E
LVF303010	180	60	13	14.4	8.4

LVF303010 Series Specification

11 PACKAGING

11.4 Tape Dimensions in mm

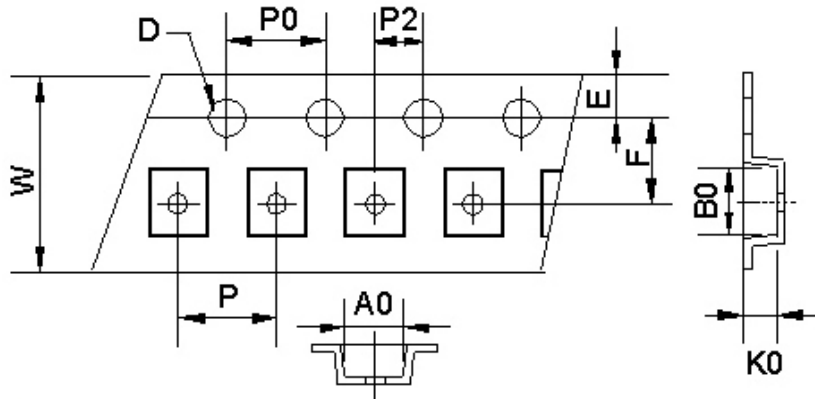

TYPE	A0	B0	K0	D	E	F	W	P	P0	P2
LVF303010	3.2	3.2	1.4	1.55	1.75	3.5	8	4	4	2

12 Recommended Pattern

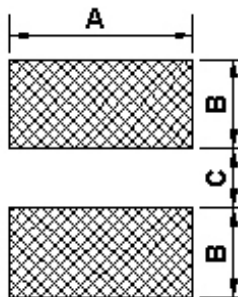

Dimensions in mm

TYPE	A(m/m)	B(m/m)	C(m/m)
LVF303010	3.2	1.1	1.0

13 Note:

1. Please make sure that your product is has been evaluated and confirmed against your specifications when our product is mounted to your product.
2. Do not knock nor drop.
3. All the items and parameters in this product specification have been prescribed on the premise that our product is used for the purpose, under the condition and in the environment agreed upon between you and us. You are requested not to use our product deviating from such agreement.
4. Please keep the distance between transformer/coil and other components (refer to the standard IEC 950)

LVF303010 Series Specification

13 Note:

5.Storage and Handling Requirements

(1)Storage period

Use the products within 12 months after delivered

Solderability should be checked if this period is exceeded

(2)Storage conditions

*Products should be stored in the warehouse on the following conditions

Temperature: $-10^{\circ}\text{C} \sim 40^{\circ}\text{C}$

Humidity : 30% ~ 70% relative humidity no rapid change on temperature and humidity

The electrode of the products is coated with solder. Don't keep products in corrosive gases such as sulfur, chlorine gas or acid, or it may cause oxidization of electrode, resulting in poor solderability.

*Products should not be stored on bulk packaging condition to prevent the chipping of the core and the breaking of winding wire caused by the collision between the products.

*Products should be stored on the palette for the prevention of the influence from humidity, dust and so on.

*Products should be stored in the warehouse without heat shock, vibration, direct sunlight and so on.

(3)Handling Condition

Care should be taken when transporting or handing product to avoid excessive vibration or mechanical shock.

6. Void Appearance tolerance Limit

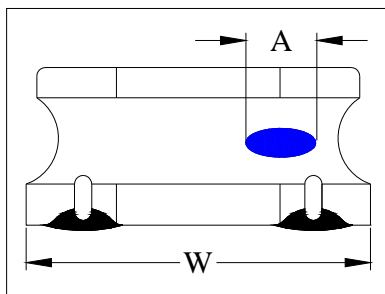

$A \leq W/2$ GOOD

$A > W/2$ NG