



With side covers

Constant Voltage Driver
**Model: LV36W24 G2
LV36W48 G2**

Model	Output Current	Input Current	Input Power	Output Power Range	PF (230V Full Load)	Efficiency (230V Full Load)	Output Voltage
LV36W24 G2	0-1500mA	≤0.21A	≤41W	0-36W	≥0.9C	≥88%	24V
LV36W48	0-750mA	≤0.2A	≤40.5W	0-36W	≥0.9C	≥89%	48V

* Test result @230V, 50Hz, Full Load.

* Recommended minimum full load power is 10% load.

1. Parameters

Category	Item	Technical Norm
Features	Output Type	Constant Voltage
	Output Features	Isolation
	IP Grade	IP20
	Insulation Class	Class I
Input	Rated Input Voltage	220-240VAC
	Range of Input Voltage	198-264VAC
	Frequency	50/60Hz
	Input Current	≤0.21A(230VAC, full load)
	Input Power	≤41W(230VAC, full load)
	Power Factor	≥0.9(230VAC, full load)
	THD	≤15%(230VAC, full load)
	No-load Power Consumption	≤0.5W@230VAC
	Inrush Current	≤30A/16us (230VAC, full load)
Output	Output Voltage Range	24VDC ± 5% or 48VDC ± 5% (Potentiometer adjusts output voltage ± 2V)
	No Load Voltage	24VDC ± 5% or 48VDC ± 5% (Potentiometer adjusts output voltage ± 2V)
	Output Current	0-1500mA or 0-750mA
	Max. Output Power	36W
	Efficiency	≥88%(230VAC, full load)
	Current Ripple(< 120 Hz)	±5% (Imax-Imin)/(Imax+Imin)
	Output Voltage Ripple	<240mV _{PK-PK} (0.5%) or <480mV _{PK-PK} (0.5%)
	Line Regulation	±5%
Load Regulation	±5%	

	PstLM	≤1
	SVM	≤0.4
	Overshoot	<105%Vo
	Current Accuracy	±5%
	Started Delay Time	≤0.5S(230VAC, full load)
Protection	Short Circuit Protection	Auto Recovery
	Overload Protection	Auto Recovery
	Over Voltage Protection	110%-150%Vo, Auto Recovery
	Over Temperature Protection	90<Tc<110°C, Auto Recovery
	No-load Protection	Auto Recovery
	Insulation voltage	3000V 5mA 60S between P-S
	Insulation resistance	>100M ohm @ 500VDC
	Leakage current	I/P to O/P <0.7mA
Environment	Ta/Operation Temperature	-25....+50°C
	Ts/Storage Temperature	-25....+85°C
	Tc/Enclosure Temperature	85°C
	Humidity	10%....90%RH
	Atmosphere	86-108KPa
Construction	Connection Method	Push-in Terminal
	Installation	Built-in&Independent (Can be either used built-in or independent with side covers)
	PRI Wire preparation	0.75-2.5 ^² / 8-9mm
	SEC Wire preparation	0.5-2.5 ^² / 8-9mm
	Dimension	165x30x 21mm (L*W*H)
Standards	Certification	CE ENEC SAA EL
	Safety Standards	EN 61347-1:2015/A1:2021 EN 61347-2-13:2014/A1:2017 EN IEC 62384:2020 EN 62493:2015 AS61347.2.13:2018 AS/NZS61347.1:2016 Inc A1 BS EN 61347-1:2015/A1:2021 BS EN 61347-2-13:2014/A1:2017 BS EN 62493:2015 BS EN IEC 62384:2020
	EMC Standards	EN IEC 55015:2019 EN IEC 55015:2019/A11:2020 EN IEC 61000-3-2:2019/A1:2021 EN 61000-3-3:2013/A2:2021 EN 61547:2009
	Performance	EN62384:2020
	Surge	L-N/1KV (L/N)-PE/2KV
Others	RoHS	complied to 2011/65/EU
	REACH	EU Regulation (EC) No 1907/2006
	Life Time	50000h @Ta=50°C
	Warranty	5years , F.R. < 10000ppm
	Noise	≤ 24dB @Background noise ≤18dB ,Interval≥15cm

Remark:

- All Parameters, if not specified, are measured at 230VAC/50Hz and 25°C ambient temperature.
- LED Driver is a component of the luminaires, Luminaires and wire layout will affect the EMC, please check the

EMC with end products again.











3. Do not install upside down.



2. Connected quantities of different current Breaker

TYPE	Connected quantities of different current Breaker						Input Voltage	Inrush Current (A)	Time (µs)
	current (A)	10	13	16	20	25			
	Installation wire diameter	1.5mm ²	2.5mm ²	2.5mm ²	4mm ²	4mm ²			
TYPE B		31	40	49	61	77	@230VAC	19.6	534
TYPE C		49	64	78	98	122			
TYPE D		78	102	125	157	196			











3. Label







LV36W24 G2

<input type="checkbox"/> L	 KGP Electronics GmbH Hueckstraße 19 DE-58511 Lüdenscheid	LED Driver LV36W24 G2	   •tc 	 - <input type="checkbox"/> + <input type="checkbox"/> Uo ADJ 	
<input type="checkbox"/> N PRI		Constant Voltage Type for LED Only			U _{rated} =24VDC
<input type="checkbox"/> ⊕		Input Voltage: 220-240V _~			I _{range} : 1.5A Max.
wire preparation 	Power Factor (λ): ≥0.9C	Prange: 36W Max.	 		
	I _{in} : ≤0.21A	tc: 85°C ta: -25...50°C			

<input type="checkbox"/> L	 KGP Electronics GmbH Hueckstraße 19 DE-58511 Lüdenscheid	LED Driver LV36W24 G2	   •tc 	 - <input type="checkbox"/> + <input type="checkbox"/> Uo ADJ 	
<input type="checkbox"/> N PRI		Constant Voltage Type for LED Only			U _{rated} =24VDC
<input type="checkbox"/> ⊕		Input Voltage: 220-240V _~			I _{range} : 1.5A Max.
wire preparation 	Power Factor (λ): ≥0.9C	Prange: 36W Max.	 		
	I _{in} : ≤0.21A	tc: 85°C ta: -25...50°C			

LV36W48

<input type="checkbox"/> L	 KGP Electronics GmbH Hueckstraße 19 DE-58511 Lüdenscheid	LED Driver LV36W48	   •tc 	 - <input type="checkbox"/> + <input type="checkbox"/> Uo ADJ 	
<input type="checkbox"/> N PRI		Constant Voltage Type for LED Only			U _{rated} =48VDC
<input type="checkbox"/> ⊕		Input Voltage: 220-240V _~			I _{range} : 0.75A Max.
wire preparation 	Power Factor (λ): ≥0.9C	Prange: 36W Max.	 		
	I _{in} : ≤0.2A	tc: 85°C ta: -25...50°C			

<input type="checkbox"/> L	 KGP Electronics GmbH Hueckstraße 19 DE-58511 Lüdenscheid	LED Driver LV36W48	   •tc 	 - <input type="checkbox"/> + <input type="checkbox"/> Uo ADJ 	
<input type="checkbox"/> N PRI		Constant Voltage Type for LED Only			U _{rated} =48VDC
<input type="checkbox"/> ⊕		Input Voltage: 220-240V _~			I _{range} : 0.75A Max.
wire preparation 	Power Factor (λ): ≥0.9C	Prange: 36W Max.	 		
	I _{in} : ≤0.2A	tc: 85°C ta: -25...50°C			

4. Lifetime curve

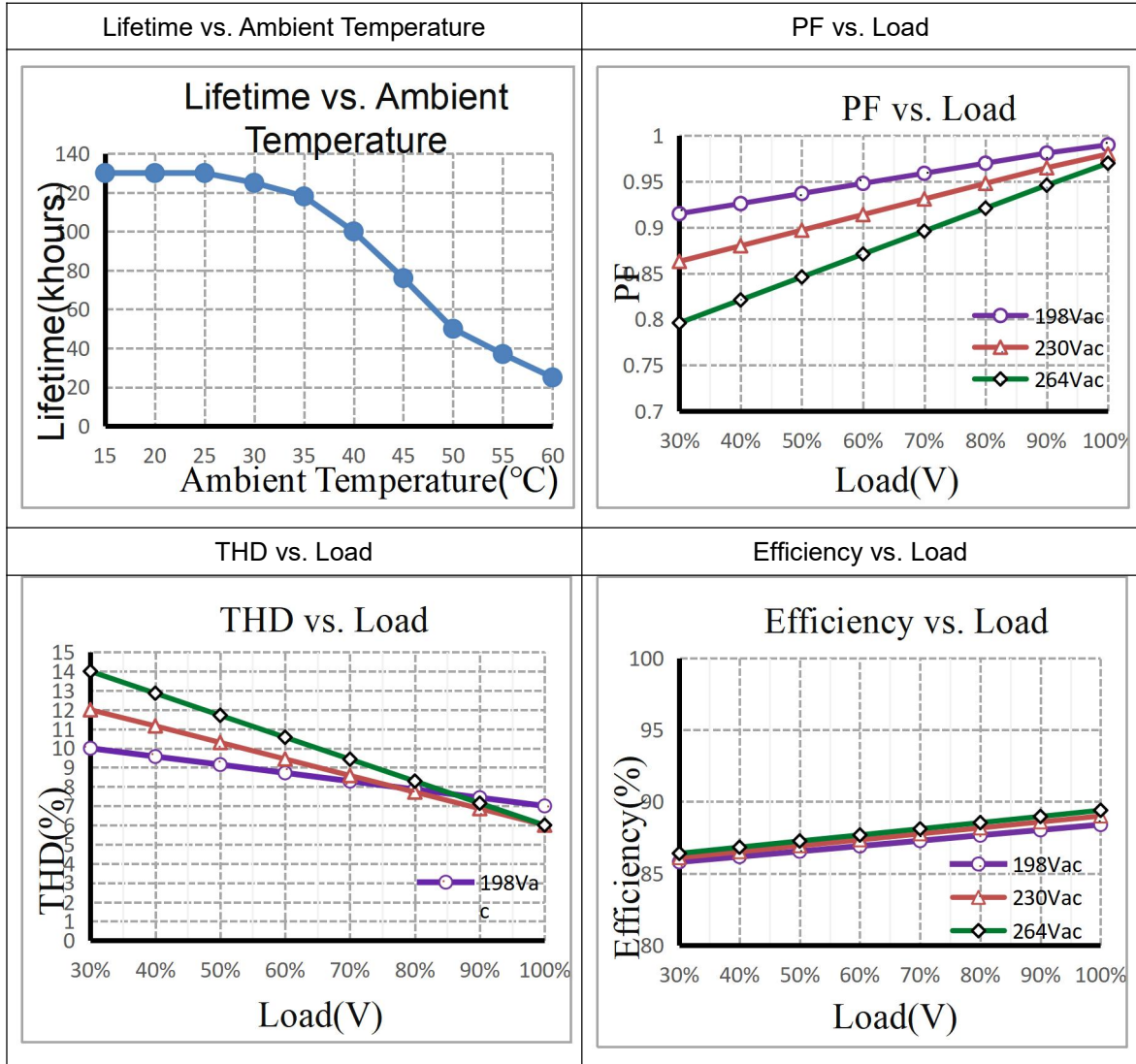

5. Dimension (Unit: mm)

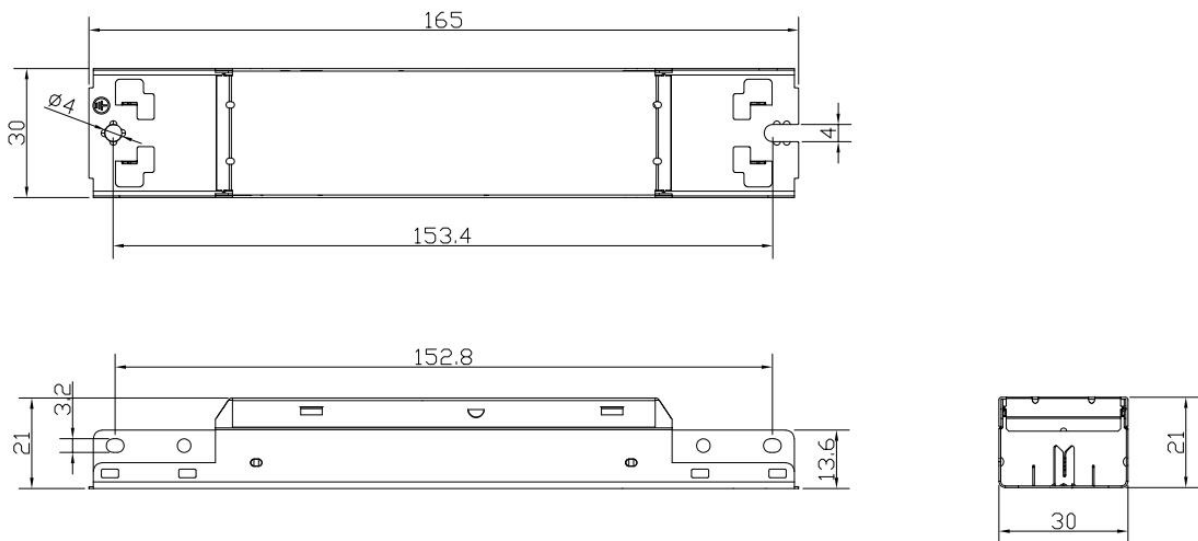

6. Packing information

Packing way	Model	Type	Carton L*W*H(mm)	Pcs/ Carton	Net weight/ Pcs(kg)	Net weight/ Carton(kg)	Gross weight/ Carton(kg)
Industrial	LV36W24 G2 LV36W48	Built-in	390*260*175	70	0.127	8.89	9.69
		Independent	425*340*180	110	0.111	12.21	12.7

7. Wiring Diagram

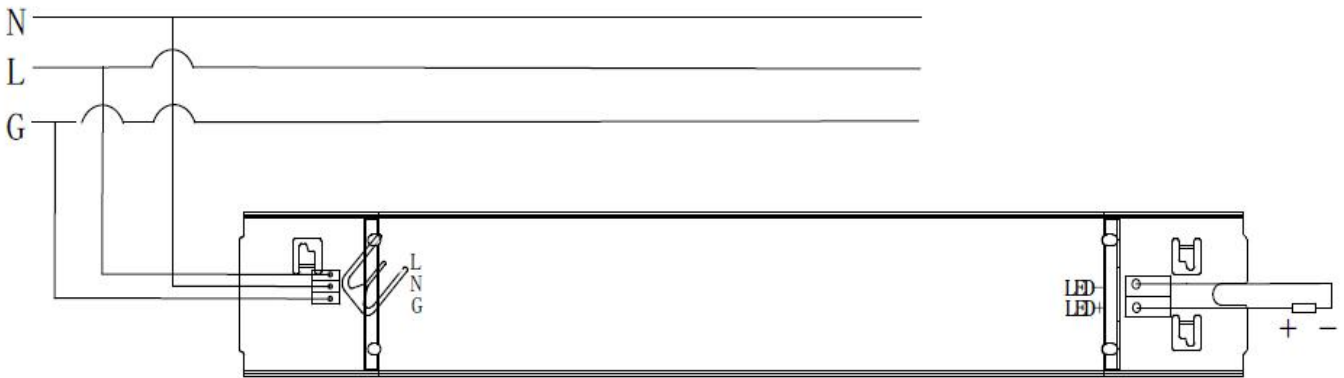

8. Wiring instructions

- All connections must be kept as short as possible to ensure good EMI behaviour
- Mains leads should be kept apart from LED Driver and other leads (ideally 5 – 10 cm distance)
- Advice the maximum length of output wires is 0.5 m
- Secondary switching is not permitted (Except for constant voltage)
- Incorrect wiring can damage LED modules.
- The wiring must be protected against short circuits to earth (sharp edged metals parts, metal cable clips, louver, etc.)
- Hot plug-in is not supported due to residual output voltage of > 0 V up to mains voltage. Danger to life.
- When connecting an LED load, restart the device to activate the LED output.

9. REVISION HISTORY

DATE	VER	REMARK
2025-01-15	V1.0	Initial release.
