



Model	Output Current	Input Current	Input Power	Output Power Range	PF	Efficiency	Output Voltage	No load Voltage
LC75W1050-1800 DALI	1050mA	0.43A	60.34W	21.00-52.50W	0.90	87.0%	20-50V	60V
	1100mA	0.44A	63.22W	22.00-55.00W	0.91	87.0%	20-50V	60V
	1150mA	0.45A	66.09W	23.00-57.50W	0.92	87.0%	20-50V	60V
	1200mA	0.46A	68.18W	24.00-60.00W	0.93	88.0%	20-50V	60V
	1250mA	0.47A	71.02W	25.00-62.50W	0.93	88.0%	20-50V	60V
	1300mA	0.48A	73.03W	26.00-65.00W	0.93	89.0%	20-50V	60V
	1350mA	0.49A	75.84W	27.00-67.50W	0.94	89.0%	20-50V	60V
	1400mA	0.50A	78.65W	28.00-70.00W	0.95	89.0%	20-50V	60V
	1450mA	0.51A	81.46W	29.00-72.50W	0.95	89.0%	20-50V	60V
	1500mA	0.52A	84.27W	30.00-75.00W	0.96	89.0%	20-50V	60V
	1550mA	0.47A	73.15W	31.00-65.10W	0.93	89.0%	20-42V	60V
	1600mA	0.48A	75.51W	32.00-67.20W	0.94	89.0%	20-42V	60V
	1650mA	0.49A	77.87W	33.00-69.30W	0.94	89.0%	20-42V	60V
	1700mA	0.50A	80.22W	34.00-71.40W	0.95	89.0%	20-42V	60V
	1750mA	0.51A	82.58W	35.00-73.50W	0.95	89.0%	20-42V	60V
	1800mA	0.52A	84.94W	36.00-75.60W	0.96	89.0%	20-42V	60V

* Test result @230V, 50Hz, Full Load













1. Parameters

category	Item	Technical Norm
Features	Output Type	Constant Current
	Dimming Type	DALI-2 / Touch DIM
	Output Features	Isolation
	IP Grade	IP20
	Insulation Class	Class I
Input	Rated Input Voltage	220-240VAC
	Range of Input Voltage	198-264VAC
	Range of DC Input Voltage	180-280VDC
	Frequency	0/50/60Hz, Range:0/47-63Hz
	Input Current	≤0.52A max
	Input Power	≤84.9W max
	Power Factor	≥0.96 (230VAC, full load)
	THD	≤8.5% (230VAC, full load)
	Standby Power Consumption	≤0.45W @230VAC (DIM to off)
	Inrush Current	≤27A/16.8us (230VAC, full load)
	Connected quantity of 10A Breaker	7pcs/type A ;12pcs/type B ;19pcs/type C
	Connected quantity of 16A Breaker	12pcs/type A ;19pcs/type B ;30pcs/type C
Connected quantity of 20A Breaker	14pcs/type A ;23pcs/type B ;37pcs/type C	
Output	Output Voltage	20-50VDC@1050-1500mA 20-42VDC@1550-1800mA
	No Load Voltage (Uout)	60VDC Max.
	Output Current	1050-1800mA (Factory set current of 1050mA)
	Max. Output Power	75.6W
	Efficiency	≥89% (230VAC, full load@max current)
	Output LF current ripple (< 120 Hz)	±3% (Imax-Imin) / (Imax+Imin)
	Current Accuracy	±5%
	Output PstLM (at full load)	≤1
	Output SVM (at full load)	≤0.4
	Starting Time (AC mode)	≤0.8S (230VAC, full load, by DALI system)
	Starting Time (DC mode)	≤0.4S
	Switching over time (AC/DC)	≤0.4S
Control Method	Secondary PUSH dimming	Secondary PUSH dimming (Max. lead wire length: 20m, same port of DALI)
	PUSH-button	Max parallel connections qty for Push-dim 15
	DALI function	DALI dimming (Max. lead wire length: 300m) logarithm or linear dimming curve selectable
	Dimming range	DALI dimming: 1%-100%
Protection	Short Circuit Protection	Auto Recovery
	Overload Protection	Auto Recovery (not be hot swap)
	No-load Protection	Auto Recovery
	Insulation voltage	3000V 5mA 60S between P-S,1500V 5mA 60S between P-E

	Insulation resistance	>100M ohm @ 500VDC L/N to PE
	Leakage current	< 700µA, I/P to O/P or I/P to PE @230V input
Environment	Ta/Operation Temperature	-25....+50°C
	Ts/Storage Temperature	-25....+90°C
	Tc/Enclosure Temperature	90°C
	Humidity	10%....90%RH
	Atmosphere	86-108KPa
Construction	Connection Method	Push-in Terminal
	Installation	Build-in
	PRI Wire preparation	0.5-1.5 [□] / 8-9mm
	SEC Wire preparation	0.5-1.5 [□] / 8-9mm
	DALI Wire preparation	0.5-1.5 [□] / 8-9mm
	Dimension	280*29.4*21mm (L*W*H)
Standards	Certification	CE/ENEC/SAA/UKCA/CB
	Safety Standards	EN61347-1:2015/A1:2021; EN61347-2-13:2014/A1:2017; EN62384:2006/A1:2009; AS 61347.2.13:2018; AS/NZS61347.1:2016; BS EN61347-1:2015/A1:2021; BS EN61347-2-13:2014/A1:2017; IEC 61347-2-13:2014; IEC 61347-1:2015
	EMC Standards	AS/NZS CISPR 15:2011; AS CISPR 15:2017 ;
	Performance	EN 62384
	DALI performance	EN 62386-101 (DALI-2) EN 62386-102 (DALI-2) EN 62386-207 (DALI-2, including part 251, 252, 253)
	Surge	L-N/1KV (L/N)-PE/2KV
Others	RoHS	2011/65/EU
	Life Time	50000h Tc=90°C
		75000h Tc=85°C
100000h Tc=80°C		
	Warranty	5years , F.R. < 10000ppm

Remark: 1.All Parameters, if not specified, are measured at 230VAC/50Hz and 25°C ambient temperature.
 2.LED Driver is a component of the luminaires, Luminaires and wire layout will affect the EMC, please check the EMC with end products again.
 3.During the PUSH DIM test, the number of parallel connections must be less than 15PCS.

2. Label

<input type="checkbox"/> L <input type="checkbox"/> N <input type="checkbox"/> DA <input type="checkbox"/> DA	 KGP KGP Electronics GmbH Hueckstraße 19 DE-58511 Lüdenscheid	LED Dimmable Driver LC75W1050-1800 DALI Constant Current Type for LED Only Input Voltage:220-240VAC Iin:≤0.52A Input Frequency:0/50-60Hz Prange=21-75.6W Range of application Uout:60VDC Max.75.6W DC 180-280V Tc:90°C Ta:50°C SEC:1050-1800mA 20-50VDC	           wire preparation 8-9mm PRI: 0.5-1.5 [□] DALI: 0.5-1.5 [□] SEC: 0.5-1.5 [□]	<table border="1"> <thead> <tr> <th>Pout (W)</th> <th>Iout (mA)</th> <th>λ</th> <th>1</th> <th>2</th> <th>3</th> <th>4</th> <th>Pout (W)</th> <th>Iout (mA)</th> <th>λ</th> <th>1</th> <th>2</th> <th>3</th> <th>4</th> </tr> </thead> <tbody> <tr> <td>52.5</td> <td>1050</td> <td>0.90C</td> <td>-</td> <td>-</td> <td>-</td> <td>-</td> <td>72.5</td> <td>1450</td> <td>0.95</td> <td>ON</td> <td>-</td> <td>-</td> <td>-</td> </tr> <tr> <td>55.0</td> <td>1100</td> <td>0.91C</td> <td>-</td> <td>-</td> <td>-</td> <td>ON</td> <td>75.0</td> <td>1500</td> <td>0.96</td> <td>ON</td> <td>-</td> <td>-</td> <td>ON</td> </tr> <tr> <td>57.5</td> <td>1150</td> <td>0.92C</td> <td>-</td> <td>-</td> <td>ON</td> <td>-</td> <td>65.1</td> <td>1350</td> <td>0.93C</td> <td>ON</td> <td>-</td> <td>ON</td> <td>-</td> </tr> <tr> <td>60.0</td> <td>1200</td> <td>0.93C</td> <td>-</td> <td>-</td> <td>ON</td> <td>ON</td> <td>67.2</td> <td>1350</td> <td>0.94C</td> <td>ON</td> <td>-</td> <td>ON</td> <td>ON</td> </tr> <tr> <td>62.5</td> <td>1250</td> <td>0.93C</td> <td>-</td> <td>ON</td> <td>-</td> <td>-</td> <td>69.3</td> <td>1350</td> <td>0.94C</td> <td>ON</td> <td>ON</td> <td>-</td> <td>-</td> </tr> <tr> <td>65.0</td> <td>1300</td> <td>0.93C</td> <td>-</td> <td>ON</td> <td>ON</td> <td>-</td> <td>71.4</td> <td>1400</td> <td>0.95</td> <td>ON</td> <td>ON</td> <td>-</td> <td>ON</td> </tr> <tr> <td>67.5</td> <td>1350</td> <td>0.94C</td> <td>-</td> <td>ON</td> <td>ON</td> <td>ON</td> <td>73.5</td> <td>1450</td> <td>0.95</td> <td>ON</td> <td>ON</td> <td>ON</td> <td>-</td> </tr> <tr> <td>70.0</td> <td>1400</td> <td>0.95</td> <td>-</td> <td>ON</td> <td>ON</td> <td>ON</td> <td>75.6</td> <td>1500</td> <td>0.96</td> <td>ON</td> <td>ON</td> <td>ON</td> <td>ON</td> </tr> </tbody> </table>	Pout (W)	Iout (mA)	λ	1	2	3	4	Pout (W)	Iout (mA)	λ	1	2	3	4	52.5	1050	0.90C	-	-	-	-	72.5	1450	0.95	ON	-	-	-	55.0	1100	0.91C	-	-	-	ON	75.0	1500	0.96	ON	-	-	ON	57.5	1150	0.92C	-	-	ON	-	65.1	1350	0.93C	ON	-	ON	-	60.0	1200	0.93C	-	-	ON	ON	67.2	1350	0.94C	ON	-	ON	ON	62.5	1250	0.93C	-	ON	-	-	69.3	1350	0.94C	ON	ON	-	-	65.0	1300	0.93C	-	ON	ON	-	71.4	1400	0.95	ON	ON	-	ON	67.5	1350	0.94C	-	ON	ON	ON	73.5	1450	0.95	ON	ON	ON	-	70.0	1400	0.95	-	ON	ON	ON	75.6	1500	0.96	ON	ON	ON	ON	<input type="checkbox"/> SEC <input type="checkbox"/> I <input type="checkbox"/> □ 
Pout (W)	Iout (mA)	λ	1	2	3	4	Pout (W)	Iout (mA)	λ	1	2	3	4																																																																																																																						
52.5	1050	0.90C	-	-	-	-	72.5	1450	0.95	ON	-	-	-																																																																																																																						
55.0	1100	0.91C	-	-	-	ON	75.0	1500	0.96	ON	-	-	ON																																																																																																																						
57.5	1150	0.92C	-	-	ON	-	65.1	1350	0.93C	ON	-	ON	-																																																																																																																						
60.0	1200	0.93C	-	-	ON	ON	67.2	1350	0.94C	ON	-	ON	ON																																																																																																																						
62.5	1250	0.93C	-	ON	-	-	69.3	1350	0.94C	ON	ON	-	-																																																																																																																						
65.0	1300	0.93C	-	ON	ON	-	71.4	1400	0.95	ON	ON	-	ON																																																																																																																						
67.5	1350	0.94C	-	ON	ON	ON	73.5	1450	0.95	ON	ON	ON	-																																																																																																																						
70.0	1400	0.95	-	ON	ON	ON	75.6	1500	0.96	ON	ON	ON	ON																																																																																																																						

3. Output Current Setting

Output Current	1	2	3	4
1050mA	-	-	-	-
1100mA	-	-	-	ON
1150mA	-	-	ON	-
1200mA	-	-	ON	ON
1250mA	-	ON	-	-
1300mA	-	ON	-	ON
1350mA	-	ON	ON	-
1400mA	-	ON	ON	ON
1450mA	ON	-	-	-
1500mA	ON	-	-	ON
1550mA	ON	-	ON	-
1600mA	ON	-	ON	ON
1650mA	ON	ON	-	-
1700mA	ON	ON	-	ON
1750mA	ON	ON	ON	-
1800mA	ON	ON	ON	ON

4. Dimension (Unit: mm)

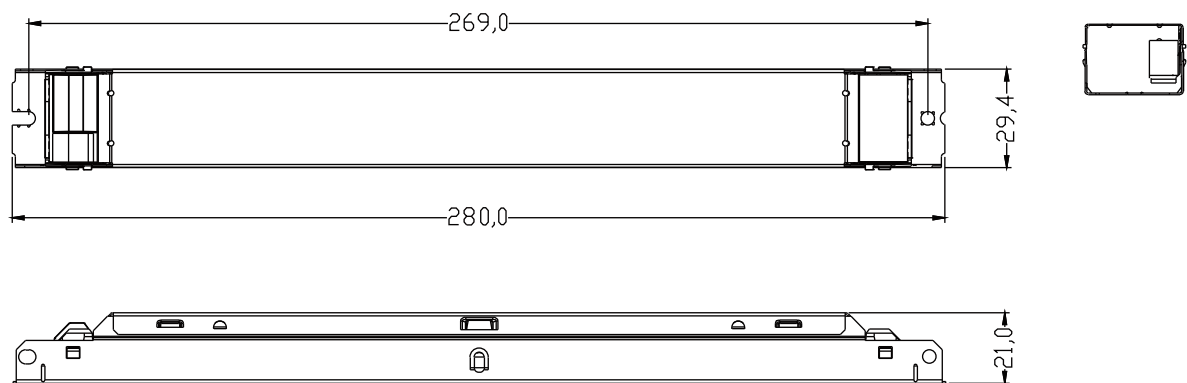

5. Installation / wiring

Circuit diagram

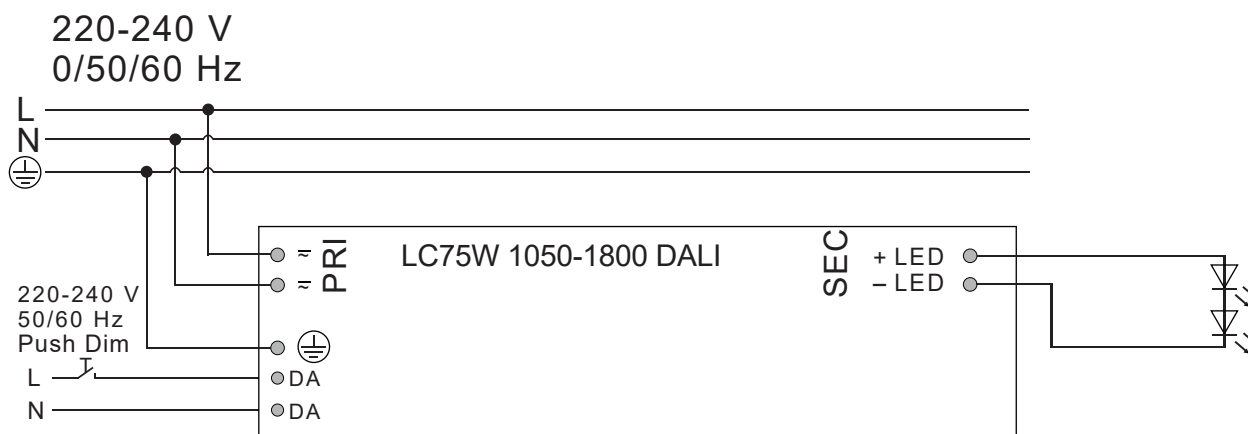
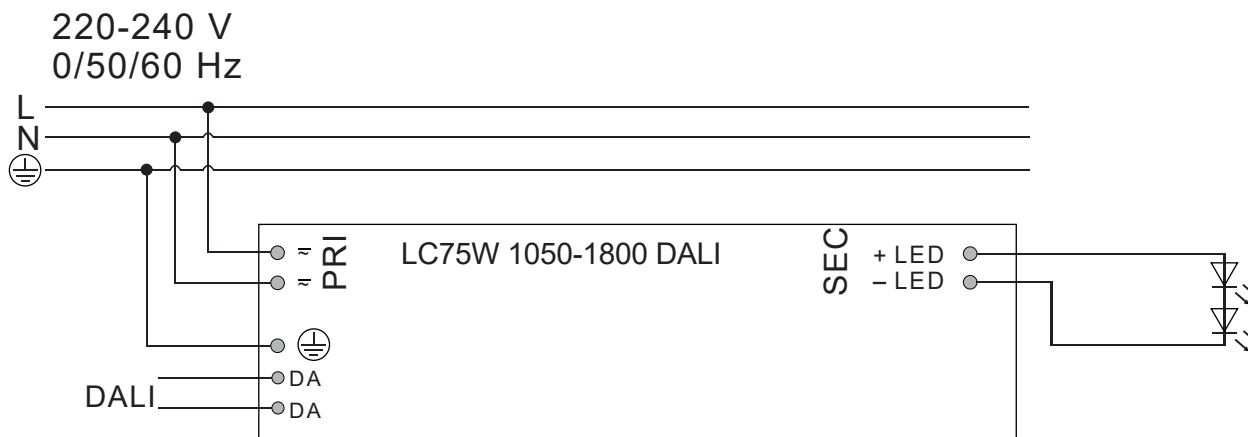

6. Output Power Window

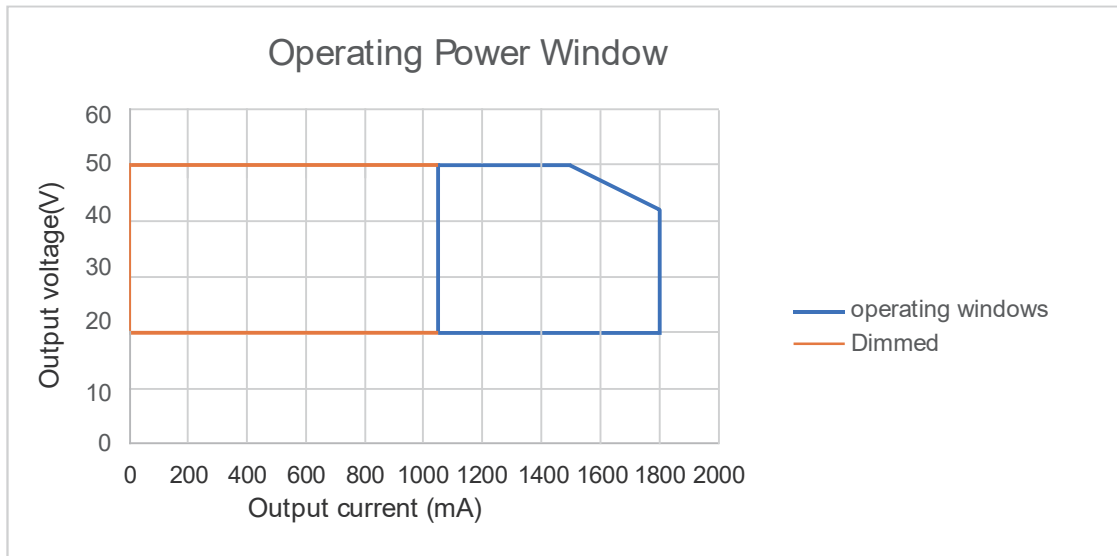

7. DALI dimming curve

formula for DALI dimming.

$$X(n) = 10^{\left\{ \left[\frac{(n-1)}{(253/3)} \right] - 1 \right\}}$$

Here, n means the target dimming stage of the total 254 stages.

X(n) means the percent of the maximum output current

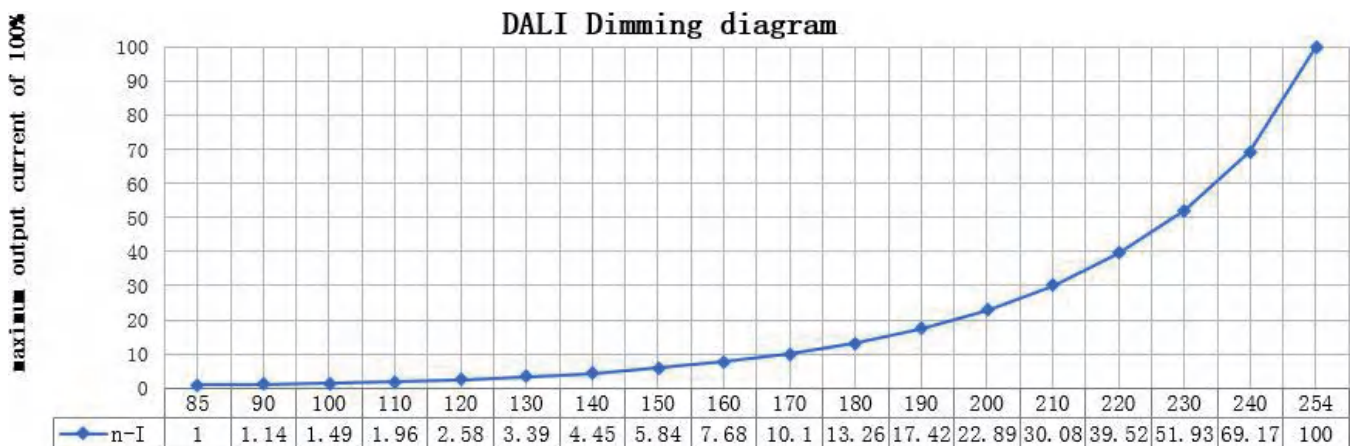

8. Packing information

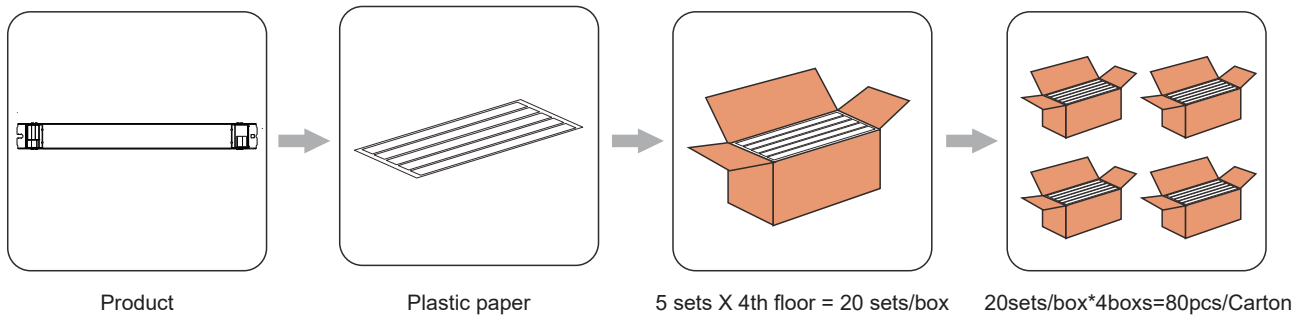

Carton L*W*H(mm)	Pcs/Carton	Net weight/ Pcs(kg)	Net weight/ Carton(kg)	Gross weight / Carton(kg)
325*303*213	80	0.165	13.20	14.52

9. Push Dim :

9.1 On / off:

Short push (120ms-600ms) on the switch

Stepless dimming: long push (> 0.6sec) on the switch

9.2 Power-on memory function

When the LED driver is powered on, it will restore the memory before the LED driver is powered off. (brightness remembers the brightness after the last dimming is stable, and the bright ness during dimming is not memorized)

9.3 Light on/off

If the light is on, the light will be off after a short press. If the light is off, the light will be on after a short press. The time range of short press is 120-600mS.

9.4 PUSH Dimming

Press and hold the push switch for a long time, the light will enter the dimming state, if the previous time is dimming, it will automatically turn to dimming the next time. After releasing the reset button, the dimming stops and the current illuminance is maintained. The dimming range is 1%-100%. The default is to dim when the power is first long-press. If the brightness of the power-on is the maximum brightness, the first long-press is to dim. (Long press 0.6-3S to start dimming.)

9.5 Forced synchronization

Long press for 10 seconds to turn on all the lights and turn on the same brightness (50%), and continue to quickly short press will not change. After a short period of time without short press operation, the module exits the synchronization mode, and the short press restores the switch function.

9.6 PUSH Dimming rate

Long press the push switch 10S to switch the dimming rate to 3S, Long press the push switch 20S to switch the dimming rate to 6S, and it can also be changed by MAGIC or production software.

10. REVISION HISTORY

Date	Revision	Remark
2023.11.02	V0.01	update images, Packing information, Parameters(Control Method, Remark)