

# **L218 Hardware Design**

---

**GSM/GPRS+GNSS Series**

**Version:** V1.1

**Date:** 2016-12-02



## Notice

Some features of the product and its accessories described herein rely on the software installed, capacities and settings of local network, and therefore may not be activated or may be limited by local network operators or network service providers.

Thus, the descriptions herein may not exactly match the product or its accessories which you purchase. Shanghai Mobiletek Communication Ltd reserves the right to change or modify any information or specifications contained in this manual without prior notice and without any liability.

## Copyright

This document contains proprietary technical information which is the property of Shanghai Mobiletek Communication Ltd. copying of this document and giving it to others and the using or communication of the contents thereof, are forbidden without express authority. Offenders are liable to the payment of damages. All rights reserved in the event of grant of patent or the registration of a utility model or design. All specification supplied herein are subject to change without notice at any time.

## DISCLAIMER

ALL CONTENTS OF THIS MANUAL ARE PROVIDED "AS IS". EXCEPT AS REQUIRED BY APPLICABLE LAWS, NO WARRANTIES OF ANY KIND, EITHER EXPRESS OR IMPLIED, INCLUDING BUT NOT LIMITED TO, THE IMPLIED WARRANTIES OF MERCHANTABILITY AND FITNESS FOR A PARTICULAR PURPOSE, ARE MADE IN RELATION TO THE ACCURACY, RELIABILITY OR CONTENTS OF THIS MANUAL.

TO THE MAXIMUM EXTENT PERMITTED BY APPLICABLE LAW, IN NO EVENT SHALL SHANGHAI MOBILETEK COMMUNICATION LTD BE LIABLE FOR ANY SPECIAL, INCIDENTAL, INDIRECT, OR CONSEQUENTIAL DAMAGES, OR LOSS OF PROFITS, BUSINESS, REVENUE, DATA, GOODWILL SAVINGS OR ANTICIPATED SAVINGS REGARDLESS OF WHETHER SUCH LOSSES ARE FORSEEABLE OR NOT.

## Version History

Date	Version	Description of change	Author
2016-09-28	V1.0	Initial	
2016-12-02	V1.1	Modify the figure and table. Add the packing instructions	Ren xue

LYNQ  
CONFIDENTIAL

## Summary

This document is intended for products: L218 module.

This document describes the hardware interface of the L218 module, can help user to quickly understand L218 interface specifications, electrical and mechanical details, with the help of this document users can use L218 module to design and set-up various types wireless terminals.

## Intended audience

This document applicable to:

- Systems Design Engineer
- Structural Engineer
- Hardware Engineer
- Software Engineer
- Test Engineer

## Introduction

This document contains contents as below:

Chapter	Content
1 Overview	Introduce L218 module basic technical SPEC. and reference standard.
2 Pin definitions	Introduce L218 module pin names and functions.
3 Hardware interface	Introduce L218 module hardware interface.
4 Module structure, size, manufacturing	Introduce L218 module structure, size, manufacturing.
5 Electrical, reliability and RF	Introduce L218 module electrical, reliability and RF.
6 Manufacturing	Introduce L218 module notice of production.
7 Package information	Introduce L218 module Package information.
8 Related documents	List L218 module related documents.

## CONTENTS

<b>1</b>	<b>INTRODUCTION</b> .....	<b>6</b>
1.1	Key Features.....	6
1.2	Module System Diagram .....	8
<b>2</b>	<b>APPLICATION INTERFACE</b> .....	<b>9</b>
2.1	PIN Assignment .....	9
2.2	PIN Description .....	10
2.3	Functional Diagram.....	12
<b>3</b>	<b>INTERFACE CIRCUIT REFERENCE DESIGN</b> .....	<b>13</b>
3.1	Power .....	13
3.1.1	Power supply .....	13
3.1.2	Power monitor .....	16
3.1.3	Power on.....	16
3.1.4	Power off .....	18
3.1.5	Reset.....	18
3.1.6	Power saving mode .....	19
3.1.7	RTC power .....	20
3.2	Audio.....	22
3.2.1	Audio channel.....	22
3.2.2	TDD noise .....	23
3.3	UART Communication.....	23
3.4	SIM Card Interface.....	29
3.5	PWM Interface.....	33
3.6	NETWORK Status Indicator .....	33
3.7	ADC Interface .....	34
3.8	GNSS and BT Function .....	35
3.9	Antenna Interface .....	35
3.10	USB Interface .....	38
3.10.1	Pin description .....	38

3.10.2 Electrical characteristics .....	38
3.10.3 USB interface applied .....	38
<b>4 MECHANICAL DIMENSIONS.....</b>	<b>39</b>
<b>5 ELECTRICAL CHARACTERISTICS .....</b>	<b>41</b>
5.1 Absolute Maximum Ratings .....	41
5.2 Working Conditions .....	41
5.3 Digital Interface Characteristics .....	41
5.4 VSIM Characteristics.....	42
5.5 Current Consumption .....	42
5.6 ESD .....	42
5.7 RF performance.....	43
<b>6 MANUFACTURING.....</b>	<b>46</b>
6.1 L218 Top And Bottom view .....	46
6.2 Soldering.....	46
6.3 The Moisture Sensitivity Level (MSL) .....	47
6.4 Baking Requirements .....	47
<b>7 PACKAGE AND STORAGE INFORMATION .....</b>	<b>49</b>
7.1 Package information .....	49
7.1.1 Tape and reel information.....	49
7.1.2 Assemble and carrier information .....	49
7.2 Bagged storage conditions.....	50
<b>8 RELATED DOCUMENTS.....</b>	<b>51</b>

# 1 INTRODUCTION

L218 is a quad-band GSM/GPRS+GNSS module, working frequency: GSM/GPRS850/900/1800/1900 MHz.

With a tiny package of 14.5mm x 18.5mm x 2.3mm, L218 fits all the applications, such as M2M, smart phone, PDA, etc.

It is a 47-pin SMT pad module, which provides rich hardware interfaces. It supports voice, SMS and data transmission with low power consumption.

## 1.1 Key Features

**Table 1-1: Main Feature**

● GSM quad-band: 850/900/1800/1900 MHz
● GSM 2/2+ standard – Class 4(2 W @ 850/900 MHz) – Class 1(1 W @ 1800/1900MHz)
● AT command (GSM 07.07 ,07.05 and Enhanced AT command set)
● GNSS: Supports GPS/GLONASS
● Power supply: 3.4 ~4.2V(Recommended 3.8V)
● Operating temperature: -40~+85°C
● Storage temperature: -45~+90°C
● weight: 1g

Data Transmission	● Coding schemes CS 1, 2, 3, 4
	● PPP-stack
	● Support pass-through
SMS	● Point to Point MO and MT
	● SMS status report
	● Text and PDU
Voice	● Half Rate(HR)
	● Full Rate(FR)
	● Text and PDU mode
	● Enhanced Full Rate(EFR)
	● Adaptive-negotiation Multi-code Rate(AMR)

● Receiver type: 33 tracking / 99 captured
--

GNSS	<ul style="list-style-type: none"> <li>● Maximum update rate: 10 Hz</li> </ul>
	<ul style="list-style-type: none"> <li>● Sensitivity           <ul style="list-style-type: none"> <li>-- Tracking: -165dBm</li> <li>-- Reacquisition: -160dBm</li> <li>-- Cold starts: -148dBm</li> </ul> </li> </ul>
	<ul style="list-style-type: none"> <li>● Time-To-First-Fix           <ul style="list-style-type: none"> <li>-- Cold start: 31s(typical)</li> <li>-- Warm start: 26s</li> <li>-- Hot starts: &lt;1s</li> <li>-- EPO Assist: 13s (CTTFF)</li> </ul> </li> </ul>
	<ul style="list-style-type: none"> <li>● Accuracy           <ul style="list-style-type: none"> <li>-- Automatic Position: 2.5m CEP</li> <li>-- Speed: 0.1m/s</li> </ul> </li> </ul>

Interface	<ul style="list-style-type: none"> <li>● 47 SMT pads (Stamps Holes)</li> </ul>
	<ul style="list-style-type: none"> <li>● One analog audio</li> </ul>
	<ul style="list-style-type: none"> <li>● One serial interfaces</li> </ul>
	<ul style="list-style-type: none"> <li>● One SIM card interface (3V/ 1.8V)</li> </ul>
	<ul style="list-style-type: none"> <li>● One ADC interface</li> </ul>
	<ul style="list-style-type: none"> <li>● GPIO interface</li> </ul>
	<ul style="list-style-type: none"> <li>● USB interface</li> </ul>
	<ul style="list-style-type: none"> <li>● GSM antenna pad</li> </ul>
	<ul style="list-style-type: none"> <li>● GPS antenna pad</li> </ul>
	<ul style="list-style-type: none"> <li>● BT antenna pad</li> </ul>

## 1.2 Module System Diagram

Following figure: List main function of module

- GSM Baseband and RF
- Power Management
- Antenna Interface
- Other interfaces

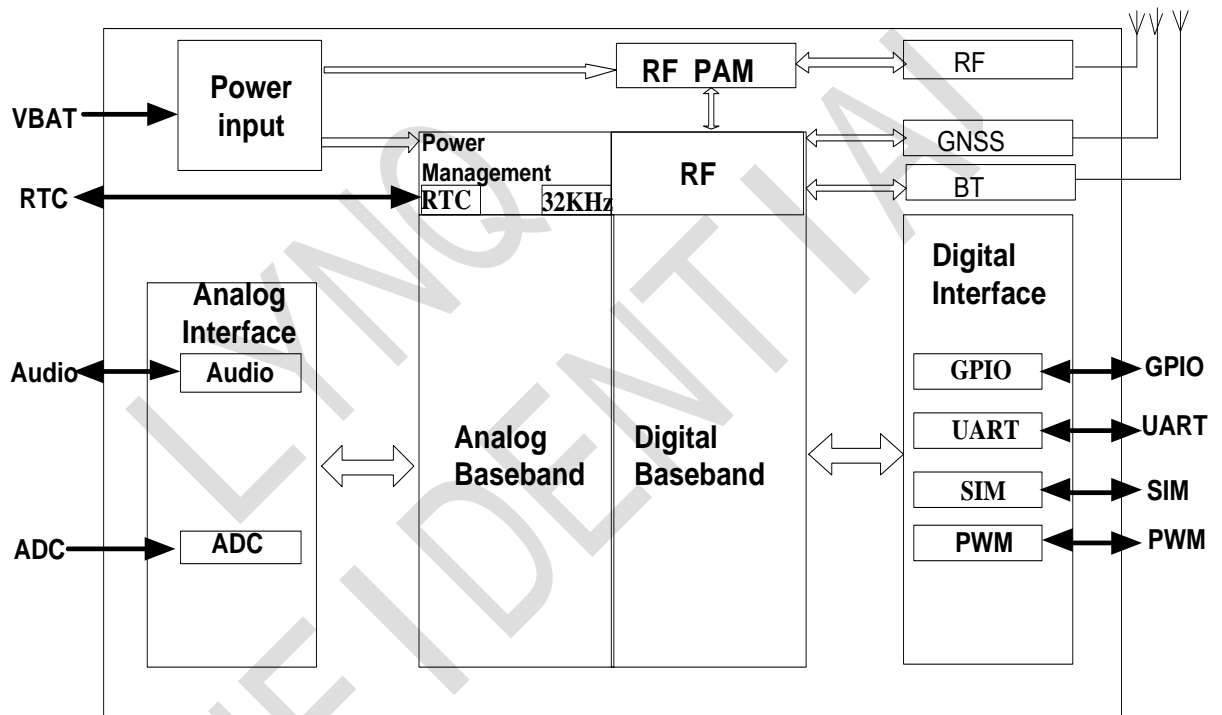
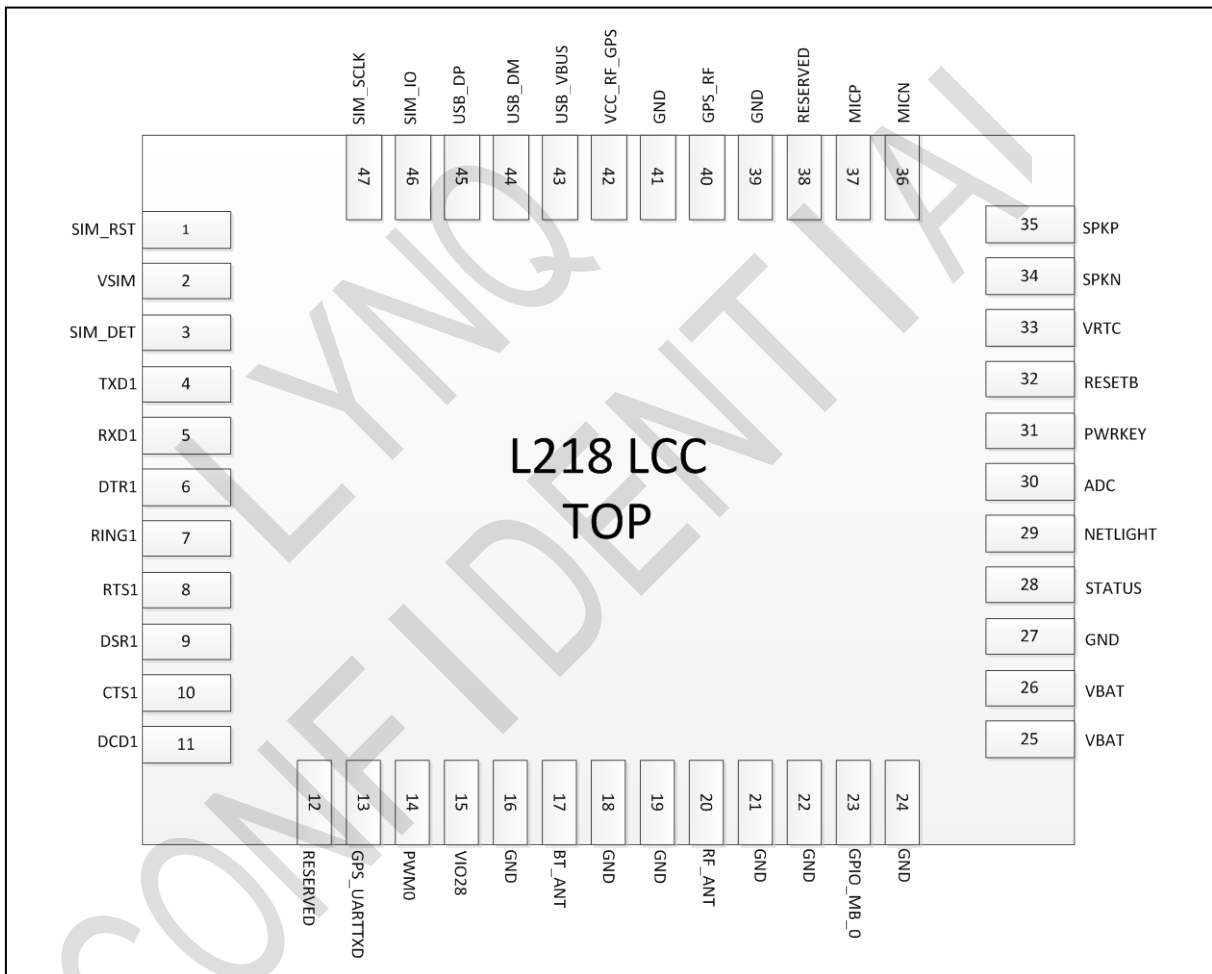


Figure 1-1: Module function diagram

## 2 APPLICATION INTERFACE

### 2.1 PIN Assignment



**Figure 1-1:** L218 Pin out diagram (TOP View)

Interfaces as below:

- Analog voice: One MIC inputs, one speaker output.
- USB: USB interface.

- SIM card: support 1.8V and 3V.
- Reset: Support RESETB pin to reset the module.
- GPIO: PIN 23 for normal general purpose in/out, and some other pins can be configured as GPIO pin (detail information in the following table).
- Serial port: Contain one full functional serial interface, CTS and RTS etc. should be NC when not used.
- RF: GSM, GNSS, BT.

## 2.2 PIN Description

L218 PIN description as below:

**Table 2-1:** PIN description

PIN NO.	PIN name	Type*	Reset	Function Description
1	SIM_RST	I/O	PD	SIM signal
2	VSIM	POWER	/	SIM signal
3	SIM_DET	I/O	PD	SIM signal
4	TXD1	O	PU	Request to Send, For AT command, firmware upgrades and data transmission.
5	RXD1	I	PU	Receive data, For AT command, firmware upgrades and data transmission.
6	DTR1	I	PD	Data terminal ready (Control module wake or sleep)
7	RING1	O	PD	Ring indicator
8	RTS1	O	PU	Request to Send
9	DSR1	O	PD	Data Set Ready
10	CTS1	I	PU	Clear to send
11	DCD1	O	PD	Data carrier detect
12	REVERSED	I/O	PD	General purpose input/output
13	GPS_UARTTXD	O	PD	GPS NEMA Output
14	PWM0	I/O	PD	PWM output
15	VIO28	POWER	/	VDDIO 2.8V output, max current is 20mA
16	GND	GND	/	GND
17	BT_ANT	I/O	/	Bluetooth antenna
18	GND	GND	/	GND

19	GND	GND	/	GND
20	RF_ANT	/	/	GSM Antenna
21	GND	GND	/	GND
22	GND	GND	/	GND
23	GPIO_MB_0	I/O	PD	General purpose input/output
24	GND	GND	/	GND
25	VBAT	POWER	/	Power supply. The power supply range is from 3.4V to 4.2V. Recommended voltage is 3.8V.
26	VBAT	POWER	/	
27	GND	GND	/	GND
28	STATUS	O	/	Running status indicator
29	NETLIGHT	I/O	PD	Net status indicator
30	ADC	AI	/	Analog to digital conversion interface, Max voltage is 2.8V.
31	PWRKEY	AI	/	PWRKEY should be pulled low at least 1 second and then released to power on/down the module
32	RESETB	I	/	Reset signal, internal pulled up to 1.8V.
33	VRTC	POWER	/	RTC voltage, input 2.8V, maximum current of 2mA. External button battery or a large capacitor, If no use can be set NC
34	SPKN	AO	/	Differential audio output.
35	SPKP	AO	/	
36	MICN	AI	/	Differential input, with internal bias voltage.
37	MICP	AI	/	
38	MIC_BIAS	POWER	/	MIC Bias output
39	GND	GND	/	GND
40	GPS_RF	/	/	FM Antenna
41	GND	GND	/	GND
42	VCC_RF_GPS	POWER	/	GPS Power Output
43	USB_VBUS	I	/	USB Power
44	USB_DM	I/O	/	USB Differential data D-
45	USB_DP	I/O	/	USB Differential data D+
46	SIM_IO	I/O	PD	SIM signal
47	SIM1_SCLK	I/O	PD	SIM signal

\* Type I, O, I/O can be configured as general GPIO, its status is PU or PD when reset.

\* The high level of the digital signal is 2.8V (min:2.6V, max3.0V).

## 2.3 Functional Diagram

Main function of module PINs listed as below

- SIM card interface
- Audio interface
- Antenna interface
- Other interfaces

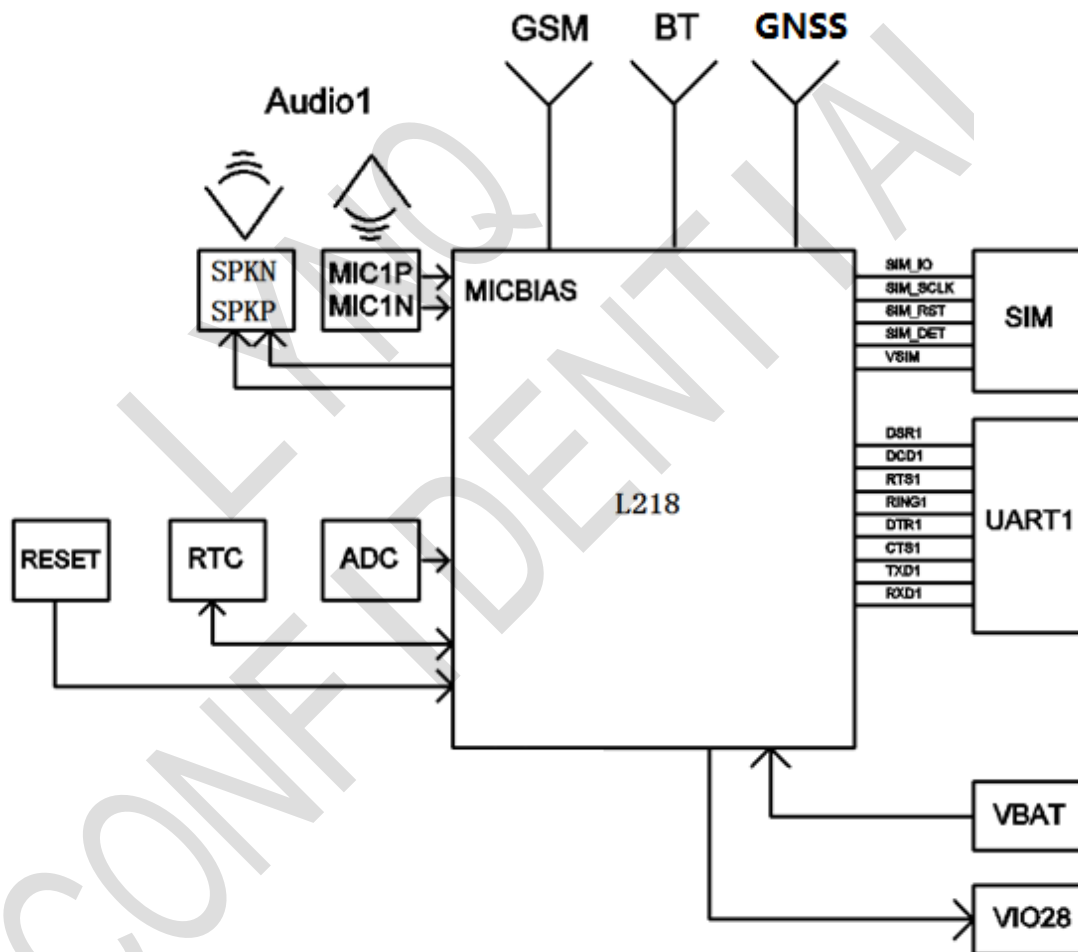


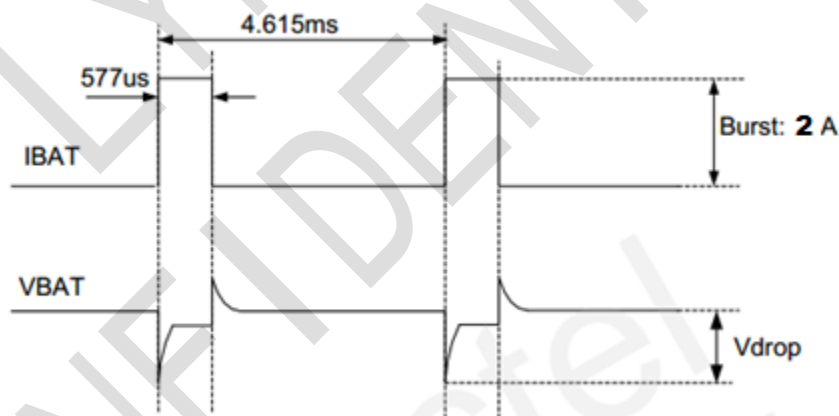
Figure 3-2: Function diagram

## 3 INTERFACE CIRCUIT REFERENCE DESIGN

### 3.1 Power

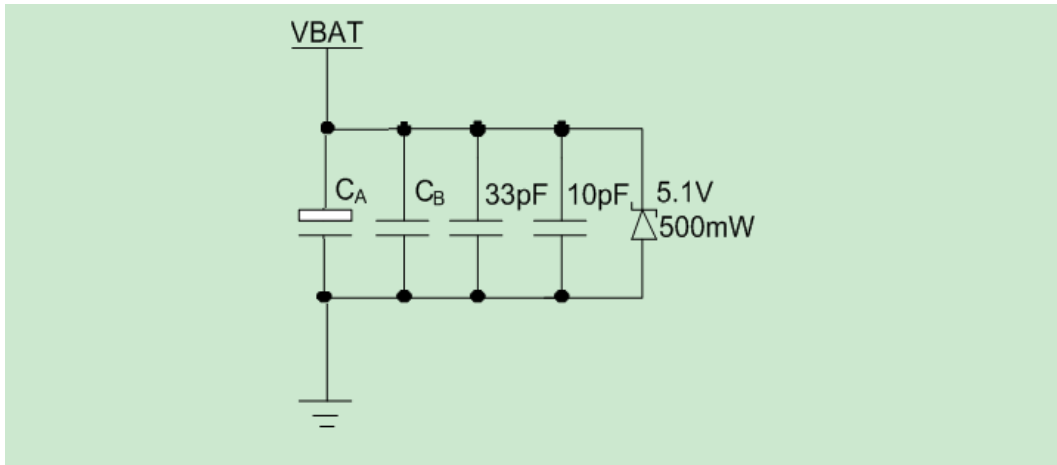
#### 3.1.1 Power supply

VBAT is the main power source of L218 module., from 3.4V to 4.2V, and 3.8V is the recommended voltage. In GSM system, RF signal works in burst transmit, a continuous 577us (1/8 of a TDMA period) burst will be found at intervals of 4.615ms. In burst period, peak current is necessary to make sure operating voltage won't drop to the base one. Because when module is working under the base voltage, the burst will cause VBAT has instantaneous large current, which the peak value could reach 2A or above and lead to the Vdrop about 350mV.



**Figure 3-1:** Module burst current and voltage waveforms

It is recommended to use a large capacitor close to VBAT PIN. The capacitor is the bigger the better to improve power stability. 470uF or more low-ESR aluminum electrolytic capacitors is recommended for CA. If the lithium battery directly connected, 220uF or 100uF tantalum capacitor (low ESR) is recommended for CB. The capacitors of 33pF and 10pF in parallel can effectively remove high-frequency interference. The capacitors should close to the VBAT pin of module.



**Figure 3-2:** VBAT input (Reference circuit)

It is strongly recommended to add a 5.1V / 500mW Zener diode to VBAT pin in parallel, Zener diode should close to the VBAT pin. Recommended parts list as below:

**Table 4-1:** Recommended Zener diode

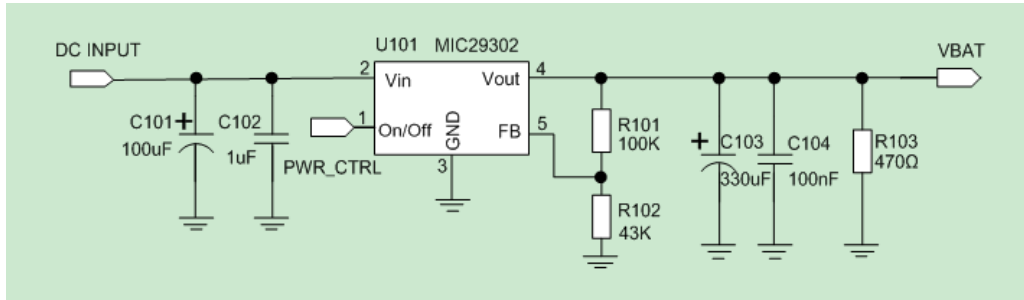
Vendor	Factory Model	Power	Encapsulation
On semi	MMSZ5231BT1G	500mW	SOD123
JCST	MMSZ5231B	500mW	SOD123
Prisemi	PZ5D4V2H	500mW	SOD523
ROHM	HDZMV4Z015.1B	500mW	UMD2
SIG	SIG1Z5T1G	500mW	SOD323
Vishay	MMSZ4689-V	500mW	SOD123
Crownpo	CDZ55C5V1SM	500mW	0805

NOTE: TVS must has a good GND nearest to interface. VRWM value cannot be too high, normally it is the 1/3 added one based on its own voltage value.

If the power supply is over 4.2V, voltage conversion is required, LDO or Buck chipset can do that function.

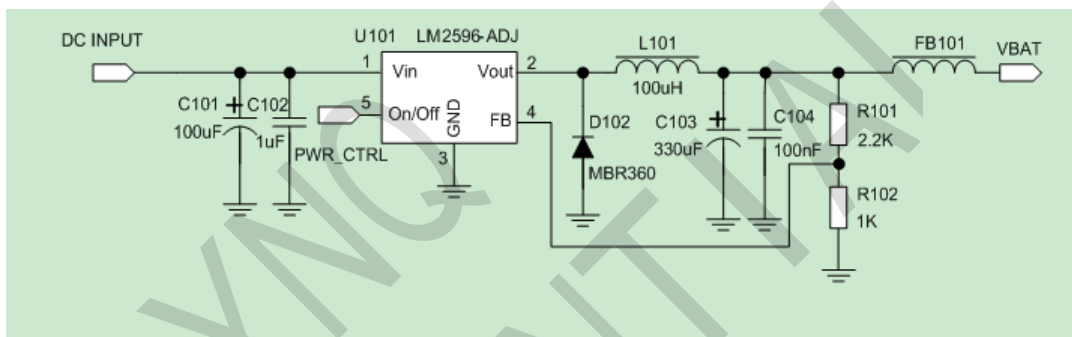
- As the LDO efficiency is closely related to the input/output dropout voltage value, the greater the voltage difference, the lower the efficiency, and at the same time, the problem of heat radiation will be detected, there is a demand of the small dropout voltage between DC input and LDO output. For instance, the voltage difference between 5V input and 4.1V output is acceptable.

The reference power supply circuit design with LDO is shown as figure below:



**Figure 3-3:** LDO (Reference circuit)

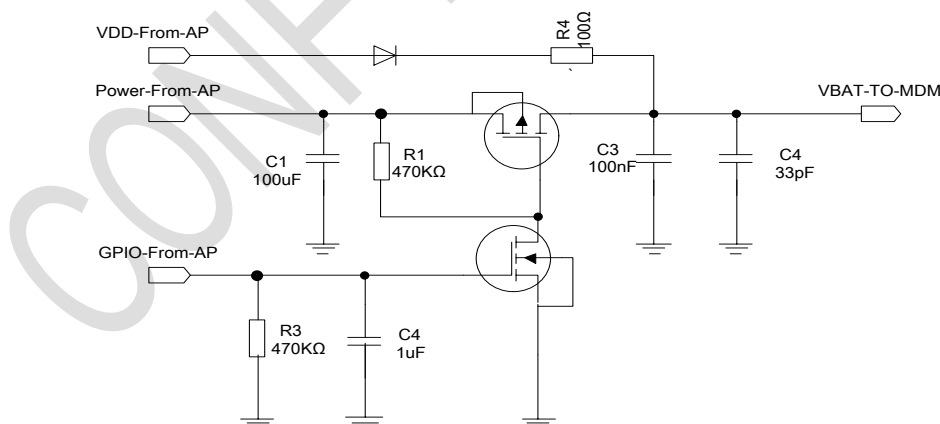
2. Buck circuit can enhance the conversion rate if the differential value is great. But meanwhile, the EMI issue caused by DCDC will be concerned.



**Figure 3-4:** DC-DC (Reference circuit)

3. PMOS control circuit for power switch.

If want to control VBAT under the circumstance that there is no need of power conversion, for example, lithium-ion battery is the direct power supply, PMOS control circuit can be the choice.



**Figure 3-5:** PMOS (Reference circuit)

### 3.1.2 Power monitor

To monitor the power supply voltage, you can use " AT+CBC " command. For details, you can refer to AT command manual.

### 3.1.3 Power on

Module to normal boot mode is through lower PWRKEY pin at least 1 second. After successful boot PWRKEY pin can be released. NETLIGHT signal can be used to determine whether module boot. When NETLIGHT start according to certain frequency output pulse signal, if connect lights, lights flashing, suggests that successful boot module. If no output pulse signal, has been as low level, no boot mod.

Recommend the following boot circuit (PWRKEY came on the module VBAT). The reference circuit is as follows:

- 1、 With triode control boot

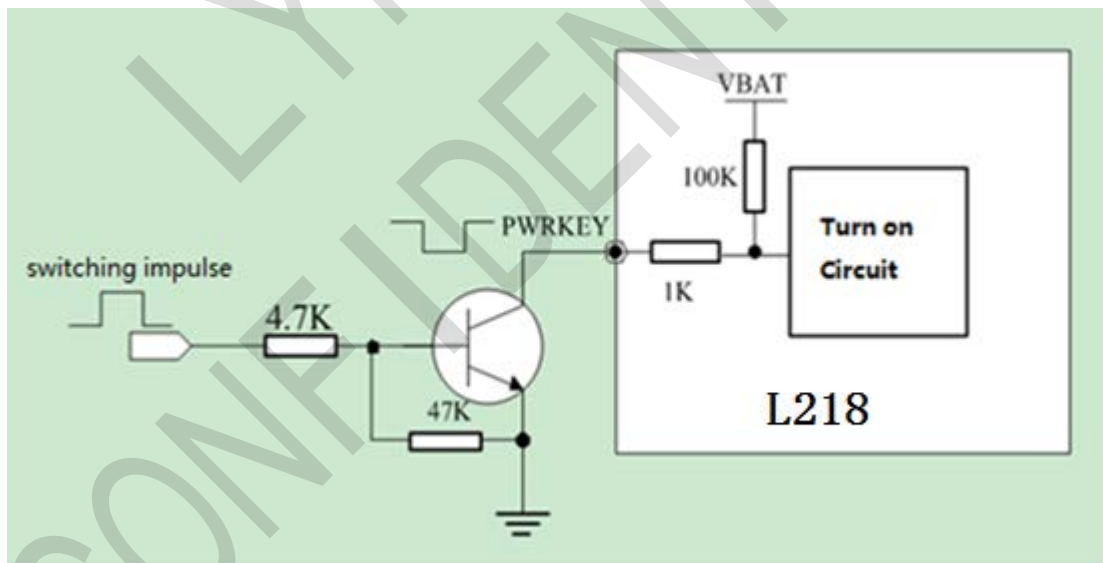
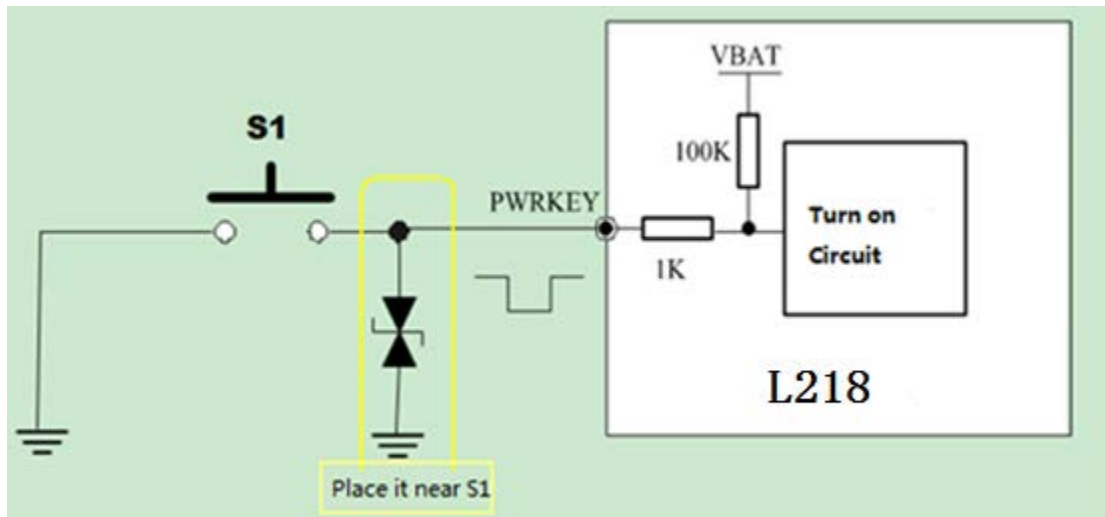


Figure 3-6: Use triode control boot

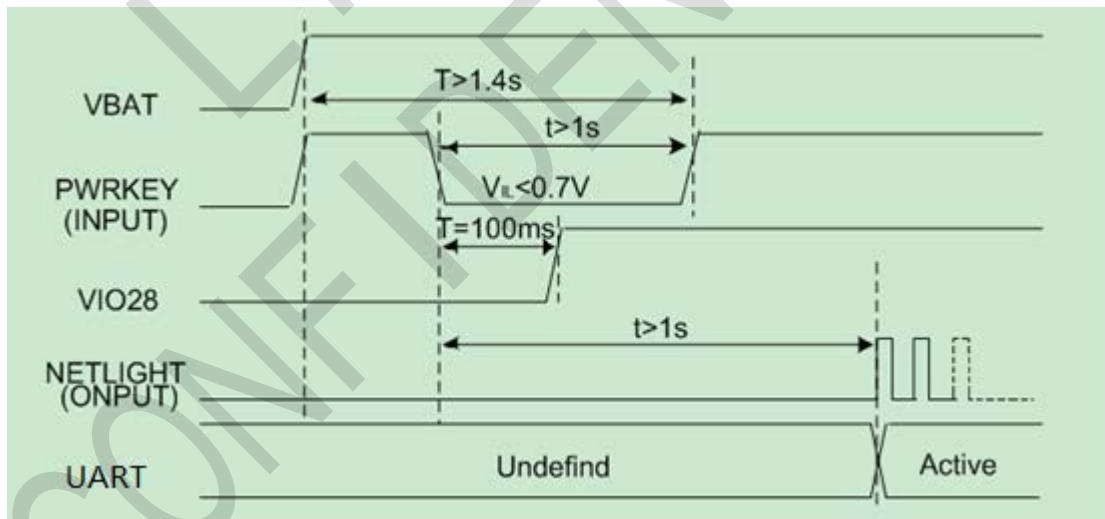
- 2、 Use key boot



**Figure 3-7:** Use key to boot

Module on the mains electricity cannot be earlier than the external MCU with electricity, prevent module on the electric moment, external MCU serial port is in unstable condition, cause the module into the mode of the error. To ensure stable operation of external MCU, then control module is powered on.

Boot sequence diagram below:



**Figure 3-8:** Boot sequence

Also pay attention to the external MCU and module connection interface level anomaly, especially the main UART port, could affect the module of the boot sequence, when switched on. For example, external MCU IO interface is in a state of output, the module of UART0 mouth UORTS signal (output pin) forced to lower or higher, the module may not be able to normal boot.

### 3.1.4 Power off

It is a safe way to turn off the module by driving the PWRKEY to a low level voltage for a certain time. The power down scenario is illustrated below.

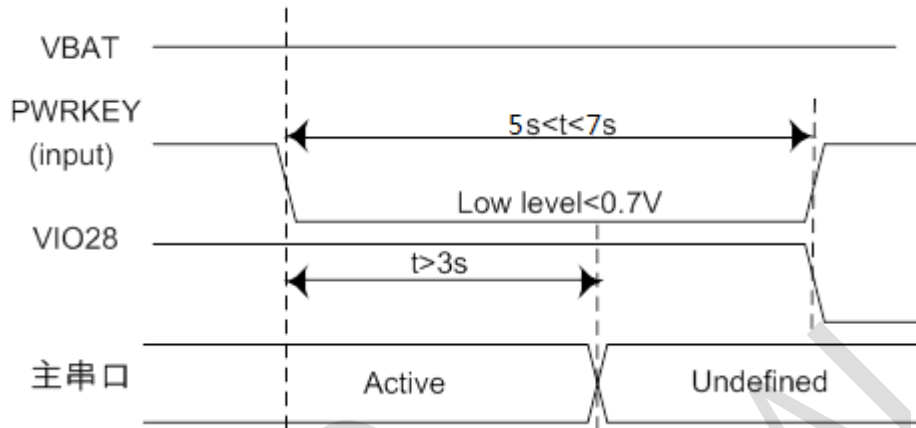
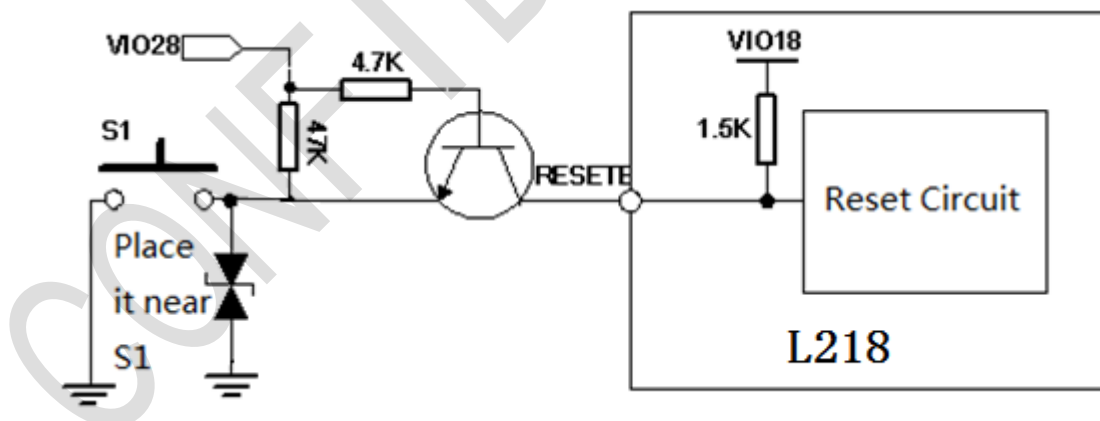


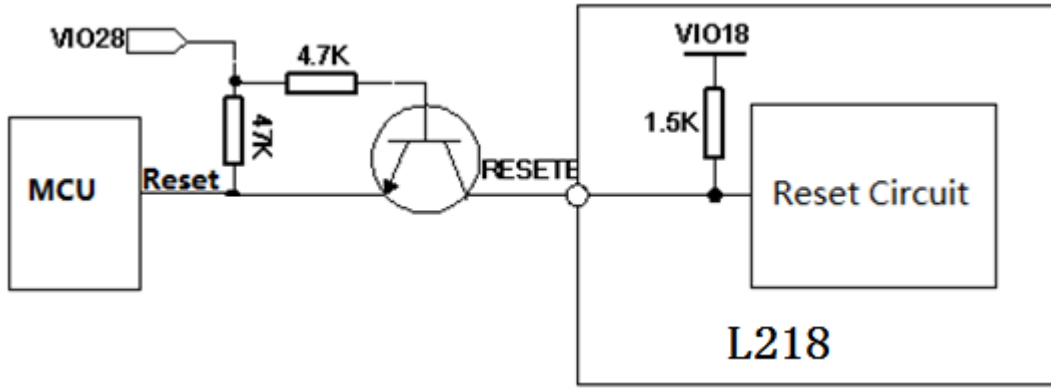
Figure 3-9 Shutdown sequence

Note: As logout network time is related to the local mobile network, it is recommended to delay about 12 seconds before disconnecting the power supply or restarting the module.

### 3.1.5 Reset

The hardware reset reference design as below (Key reset and MCU reset L218 Module):





**Figure 3-10:** Recommend the reset circuit: Key reset and MCU reset L218 Module

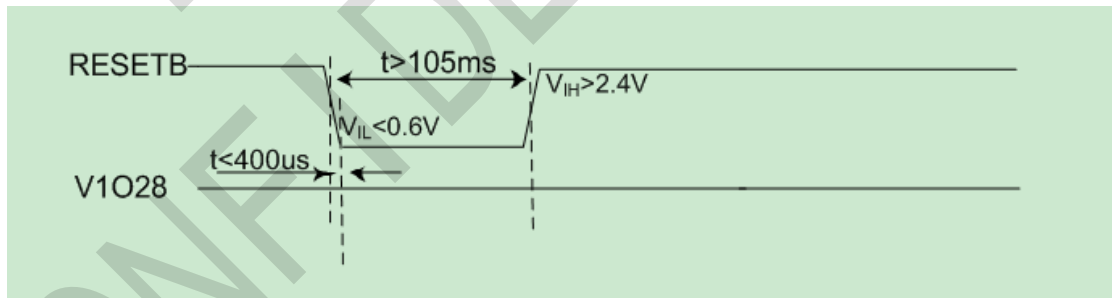
Note:

- 1, Only use under emergency, such as no AT response, PWRKEY failure.
- 2, Don't connect RESETE PIN to MCU directly.

**Table 5-2:** Electronic characteristic of the RESETE pin

PIN name	Symbol	Min	Typ	Max	Unit
RESETE	VIH	2.4	--	--	V
	VIL	--	--	0.6	V
	Low power time	105	--	--	ms

RESETE Reset timing sequence:



**Figure 3-11:** Reset timing sequence

### 3.1.6 Power saving mode

The module has a variety of ways to sleep wake up:

1, Sleep

AT Sleep:

- (1) When the module in the idle state can make through the AT + ESLP = 1 module into

sleep mode.

- (2) When the module in a busy state (e.g., GPRS data transfer, send and receive SMS, external interrupt events, etc.) when sending the AT + ESLP = 1 instruction, module after in dealing with the current task will enter the sleep mode.

DTR way dormancy:

In order to set up AT + CSCLK = 1, can be introduced into dormancy by DTR pin control module:

- (1) When the module in the idle state by raising DTR pin led module into sleep mode.
- (2) When the module in a busy state (e.g., GPRS data transfer, send and receive SMS, external interrupt events, etc.) when raising DTR pin, module after in dealing with the current task will enter the sleep mode.

## 2, Wake up

When the module into sleep mode after a serial port will not be available. Modules can be wake up by the following ways:

- (1) After receive the voice or data call, module out of sleep mode, and through the RING foot give instructions.
- (2) After receiving the short message (SMS), module out of sleep mode, and through the RING foot give instructions.
- (3) In has been set AT + CSCLK = 1 condition, will DTR1 feet down, out of hibernation, wake up the module.

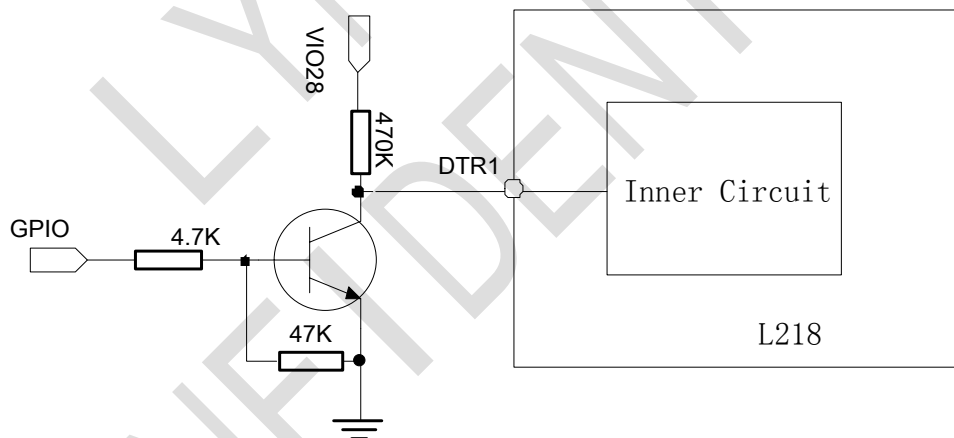
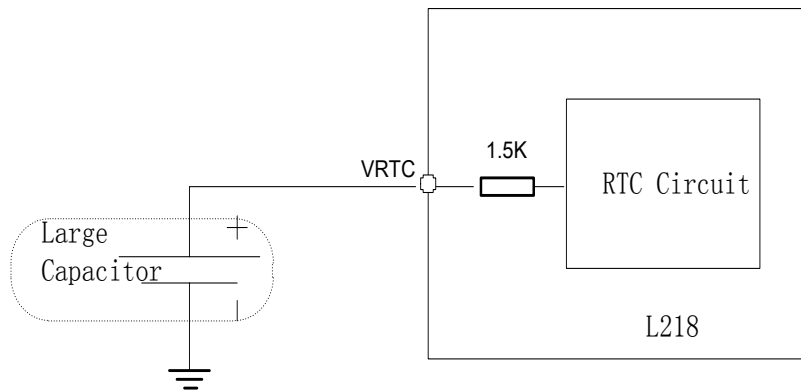


Figure 3-12: DTR circuit

## 3.1.7 RTC power

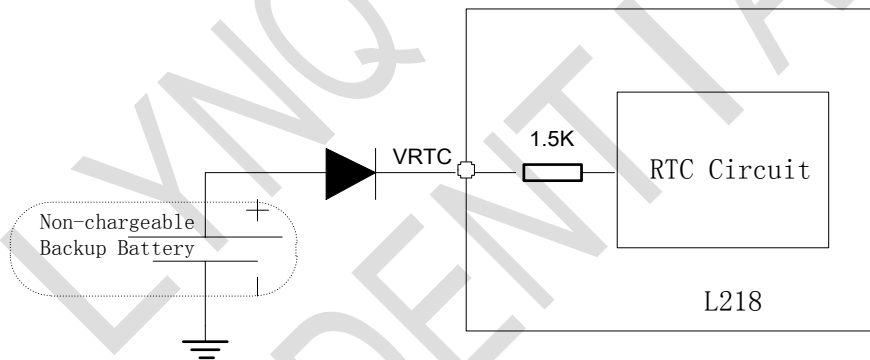
When VBAT disconnect, users need to save the real time clock, the VRTC pin can't hung up. It need an external large capacitor or batteries. When external large capacitor, the recommended value of 100uF, to keep the real time clock for 1 minute. RTC power using external large capacitor or battery to RTC power supply inside the module. Modules contain a 1.5 K current-limiting resistance. Button cell or super capacitor can be used to give the RTC power supply. Below are several to RTC power supply circuit of reference:

- External capacitor of power supply



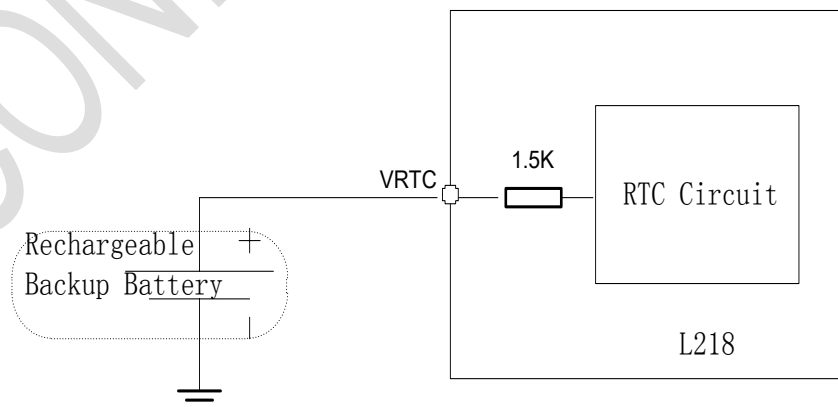
**Figure 3-13:** External capacitor to the RTC power supply

- Non-chargeable Backup battery



**Figure 3-14:** Non-rechargeable battery

- Rechargeable battery



**Figure 3-15:** Rechargeable battery

The VRTC power typical value of 2.8 V, consumption flow about 3uA when VBAT disconnect.

## 3.2 Audio

**Table 6-3:** Audio interface pin definition

NO.	PIN name	PIN NO.	Description
1	MICN	36	Audio differential input negative
2	MICP	37	Audio differential input positive
3	SPKN	34	Audio differential output negative
4	SPKP	35	Audio differential output positive

### 3.2.1 Audio channel

- 1、 The difference signal SPKN, SPKP of audio, directly connected to the speaker device.

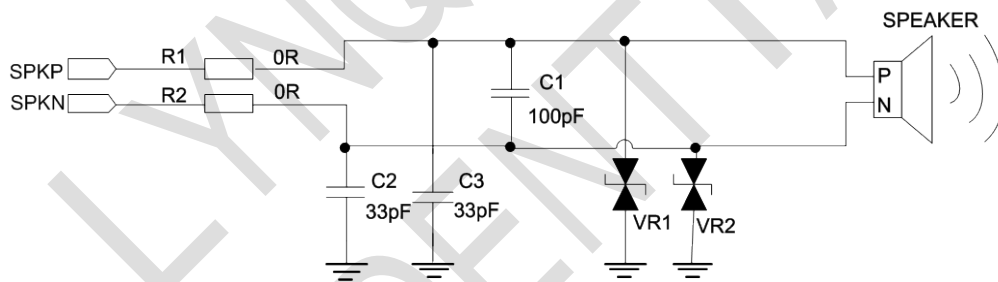


Figure 3-16: Receiver circuit

- 2、 MIC need add external MICBIAS power, external microphone can be directly connected MICP and MICN.

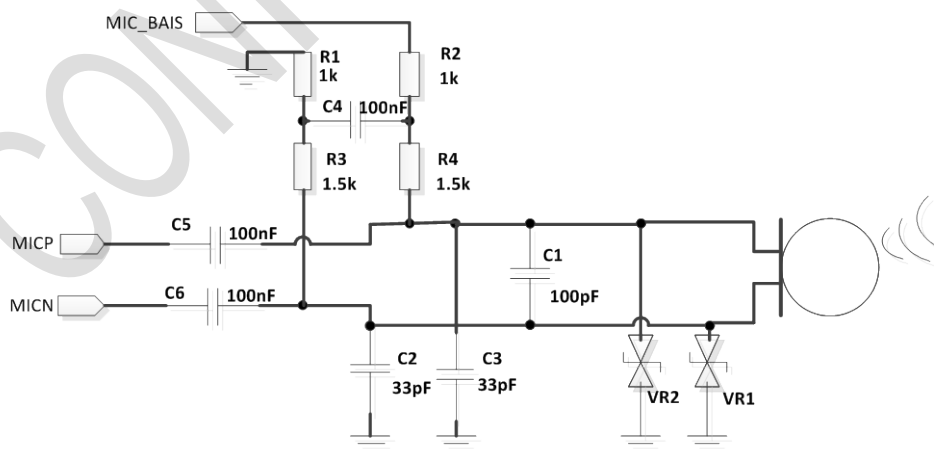


Figure 3-17: MIC (Reference circuit)

### 3.2.2 TDD noise

Electret microphone (with embedded double frequency filtering capacitor, 10pF and 47pF) is suggested to use on hand held or hand free microphone to stop RF interference and TDD noise from the beginning. If double frequency filtering capacitor is not selected, TDD noise may be heard during conversation. Please consult to capacitor provider to choose the most suitable capacitor value to filter high-frequency noise out in GSM850/GSM900/DCS1800/PCS1900MHz.

The order of noise severity in GSM band depends on application design. For instance, TDD noise is relatively serious in GSM900 or DCS1800 in different conditions. Users choose their desired filter capacitor according to their situation. The place of nearing audio element or interface is better for filter capacitor, wire layout must be shortest as it could be, through filter capacitor first. The place far away from audio element or layout is better for antenna to avoid disturbing. Power layout and audio layout cannot be parallel, and keep them in distance.

TDD noise can be affected by GND. If GND layout is not suitable, noise will disturb MIC and speaker.

Add some large capacitors or series magnetic beads during schematic diagram designing to avoid conductive interference.

Differential audio layout must abide the rules of differential signal layout.

## 3.3 UART Communication

### 3.3.1 Serial pin definition

Modules provide 2 groups of UART serial port, including UART1 support full serial port function, main effect for the AT communications, data services, software upgrades, etc. UART2 provides only the TX and RX, can be used as the AT communication, debug, etc. Module called a DCE device (Data Communication Equipment), according to the traditional DCE - DTE (Data Terminal Equipment) connection. Adaptive baud rate support range 4800bps to 115200bps.

**Table 7-4:** Serial pin definition:

Interface	PIN name	PIN NO.	Description
Serial port	DCD1	11	Data carrier detect
	RTS1	8	DTE request data
	RING1	7	Ring indicating
	DTR1	6	DTE is ready
	CTS1	10	Clear to send
	TXD1	4	Data sent
	RXD1	5	Data reception

	DSR1	9	Data Set Ready
--	------	---	----------------

### 3.3.2 Serial port characteristics

Main serial port:

- 7 signal lines. Including cable TXD and RXD, hardware flow control line RTS and CTS, and other line of DTR, DCD and RI.
- 8 data bits, No parity, One stop bit.
- Hardware flow control off by default, if use hardware flow control, use the "AT + ICF = 0" open flow control function.
- AT command transfer, GPRS data transmission.
- Support a fixed baud rate is as follows:  
2400,4800, 9600, 14400, 19200, 28800, 38400, 57600, 115200.
- The default configuration module for adaptive baud rate. Adaptive support the following baud rate: 4800,9600,19200,38400,57600,115200bps.

The baud rate is fixed or adaptive baud rate synchronization settings. And send a command string "A-T" when serial ready after module will reply "OK".

The host controller by sending "AT" command to the module, the module will automatically detect and identify the host controller's current baud rate. Adaptive baud rate function can make the host controller don't need to know the current baud rate and the module of communication will be finished. Adaptive baud rate function open by default.

Adaptive baud rate operating configuration:

- Serial interface is configured to 8 bits of data bits, parity bits, one stop bit (the factory configuration).
- Adaptive baud rate mode, if there is no first synchronization module boot, such as "RDY", "+ CFUN: 1" and "+ CPIN: READY" URC information will not be reported.
- DTE in switching to a new baud rate, will first through the "AT" set up the new baud rate, before module detection and synchronous new baud rate, the module will use previous messages URC baud rate. DTE when switch to the new baud rate, the equipment is likely to receive unrecognized characters.
- Baud rates, is not recommended in a fixed mode switch to the adaptive baud rate model

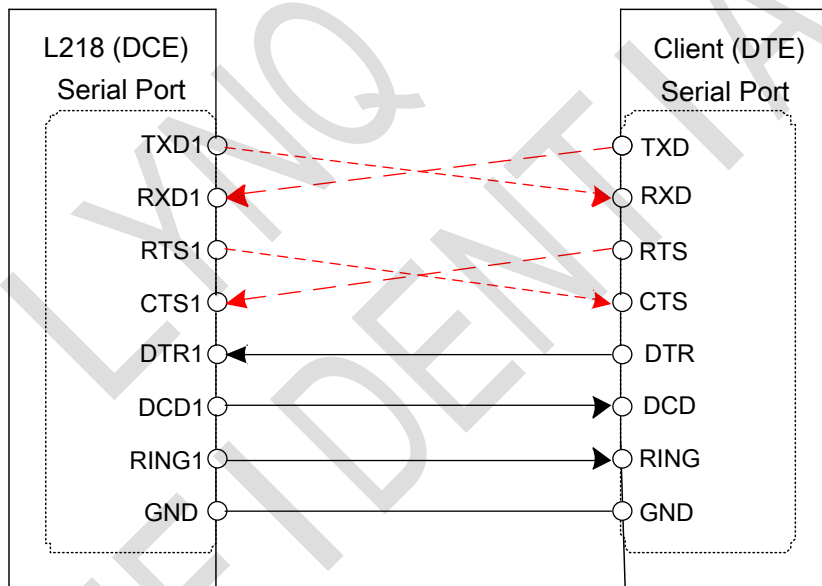
Note: the default module is adaptive baud rate (AT + IPR = 0), in the baud rate adaptive mode, after power on the URC information "RDY" will not back to the master machine. In the module boot after 2 ~ 3 seconds, can send the module AT commands. Master need to first send the "AT" the baud rate of character to the module to detect a master, and continue to send 1 ~ 5 "AT"

string until module returns "OK". Then send a "AT + IPR = x & W" command to the module set the baud rate of a fixed, and save the configuration, after completed the configuration, each module after boot, will return to a URC information via a serial port "RDY". To further understand, please refer to the document [AT\_DOCUMENT] "AT + IPR" in the chapter.

### 3.3.3 Serial port connection

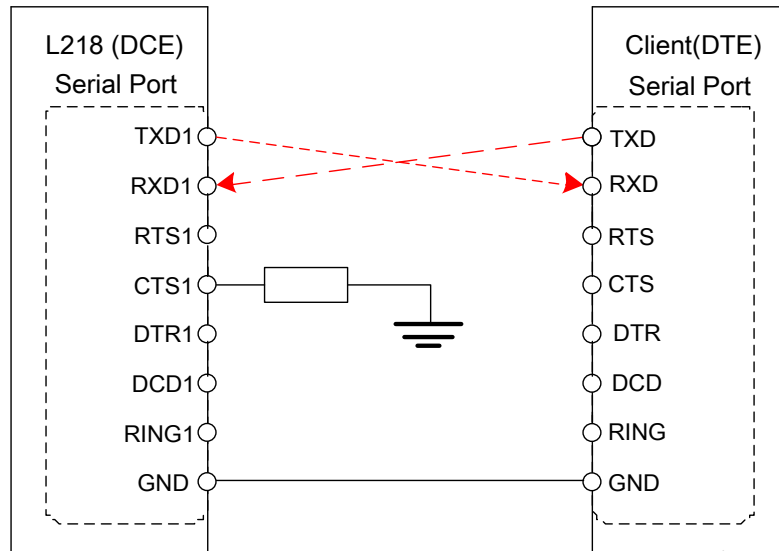
The main serial port connection mode is more flexible, as follows are three common ways of connection.

1、 Full-featured serial connection as shown in the figure below, this way is mainly used in the modem mode dial (PPP)



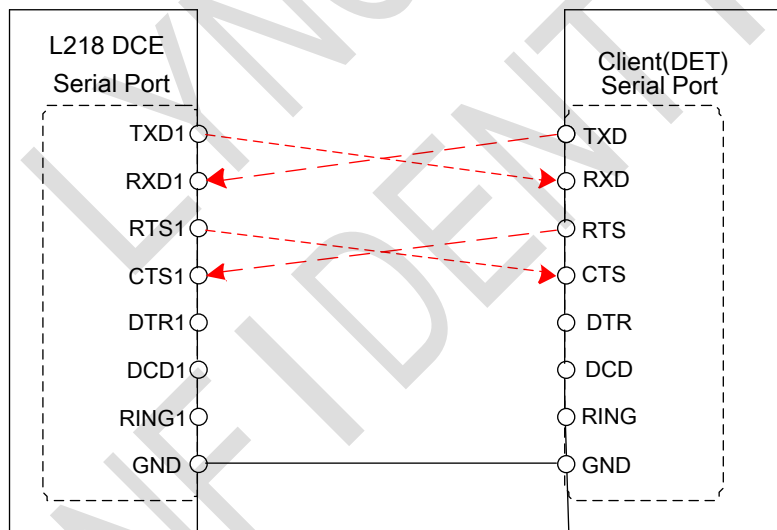
**Figure 3-18:** Full-featured serial connection

2、 Three wire system without hardware flow control of the serial port is as follows



**Figure 3-19:** Serial port three line connection

3、 Three wire system with hardware flow control of the serial port is as follows:



**Figure 3-20:** Serial flow control connection

### 3.3.4 Serial level matching

Module serial port is COMS VIO28 level signal, connected to the external MCU, it should pay attention to the matching of IO level. Normal job requirements input level lower than 3.0V, the default rate is 115200 bps.

When external MCU serial level of 3.3V, it is recommended to use the following reference circuit. If the external MCU level is 3.0 V, please change the resistance of 5.6 K to 14 K.

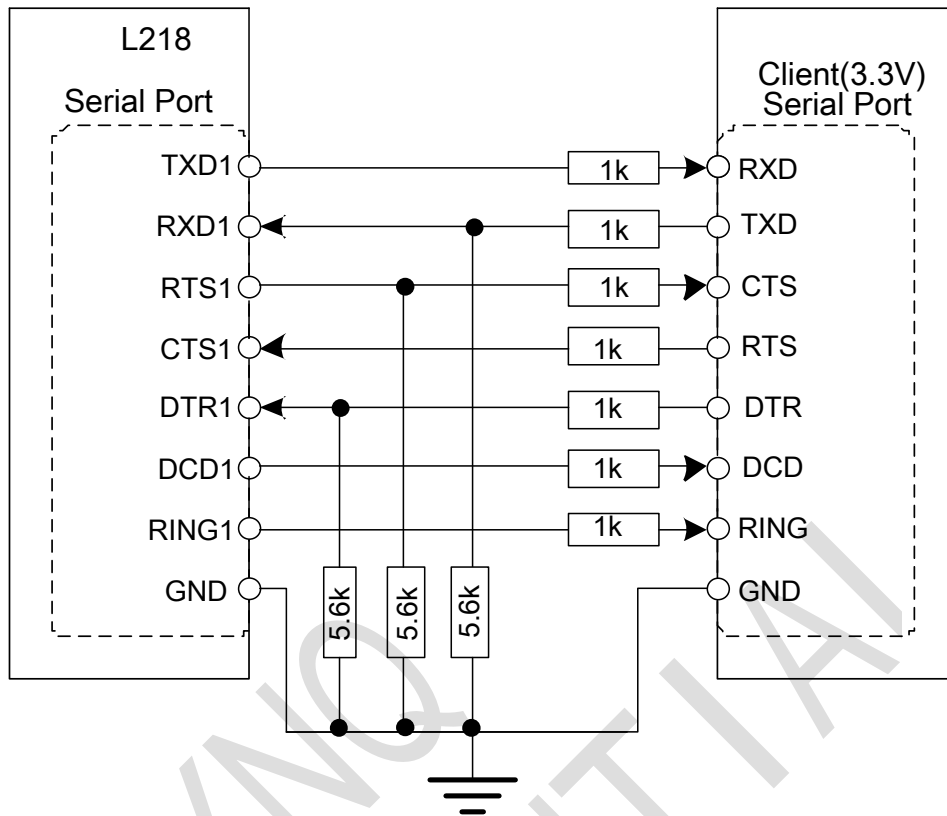
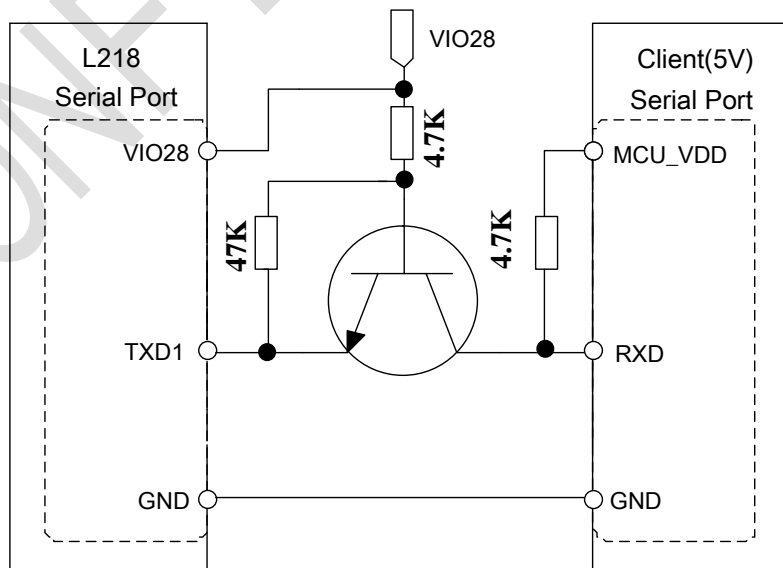


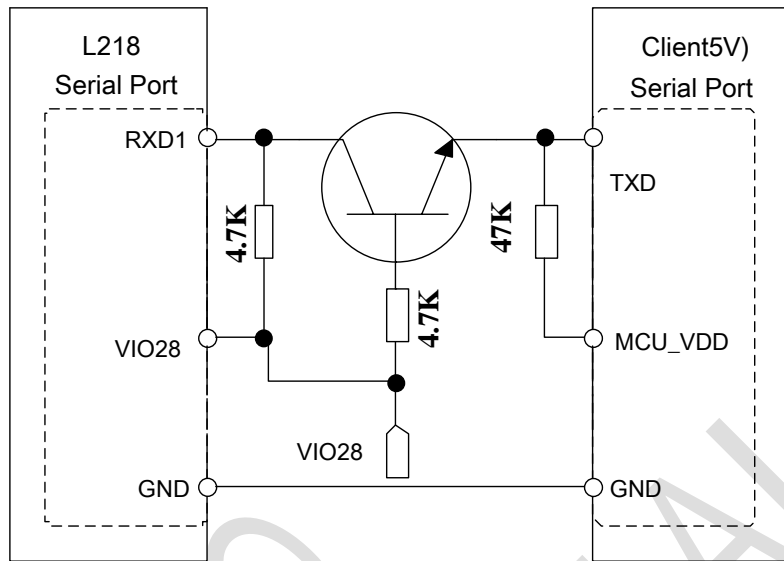
Figure 3-21: Resistor level matching (Reference circuit)

If the external host MCU serial level is 5V, can use the transistor voltage conversion circuit or use special voltage conversion circuit, the reference is as follows:

1、 Use triode to do level transformation

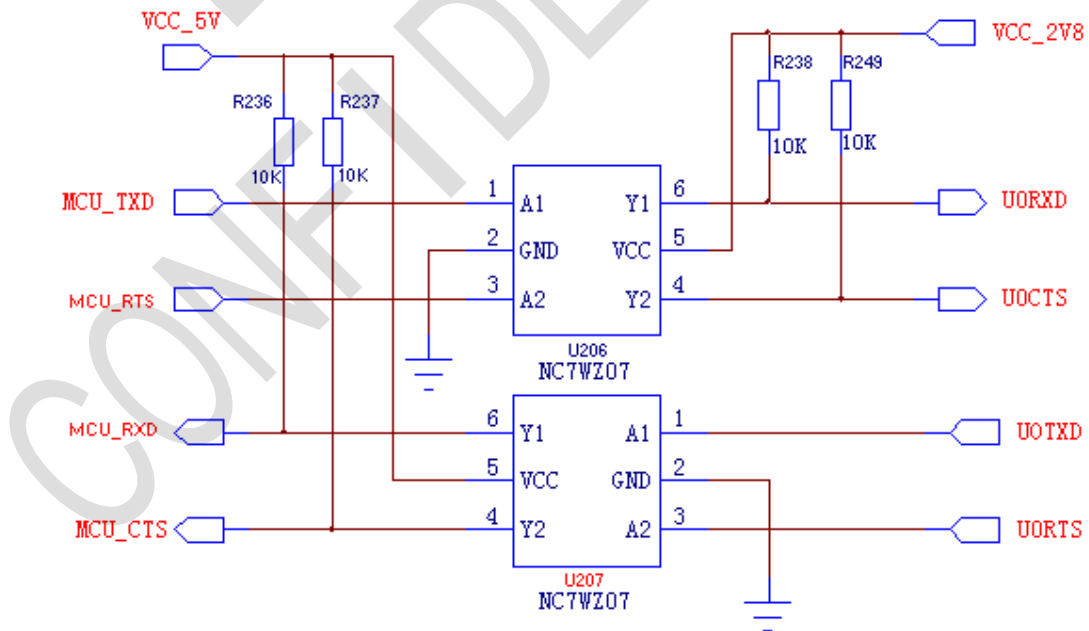


**Figure 3-22: 5V TXD level matching (Reference circuit)**



**Figure 3-23: 5V RXD level matching (Reference circuit)**

2、 Use FAIRCHILD to convert the chip NC7WZ07:



**Figure 3-24: Chip level matching (Reference circuit)**

## 3.4 SIM Card Interface

SIM card interface support GSM Phase1 specification function, also support the function of the GSM Phase 2 + specification and FAST 64 kbps SIM CARDS (for SIM application toolkit).

SIM card supports 1.8V and 3.0V power supply through the internal power supply of the module.

### 3.4.1 SIM Interface

**Table 8-5:** SIM card interface pin definition:

NO.	PIN name	PIN NO.	Description
1	SIM_IO	46	SIM card data I/O
2	SIM_SCLK	47	SIM card clock
3	SIM_RST	1	SIM card reset
4	SIM_DET	3	SIM card insert detection pin
5	VSIM	2	SIM power supply, according to the type of SIM card automatically select the output voltage, 3.0V 10% or 1.8V 10%, the output current of about 10mA.

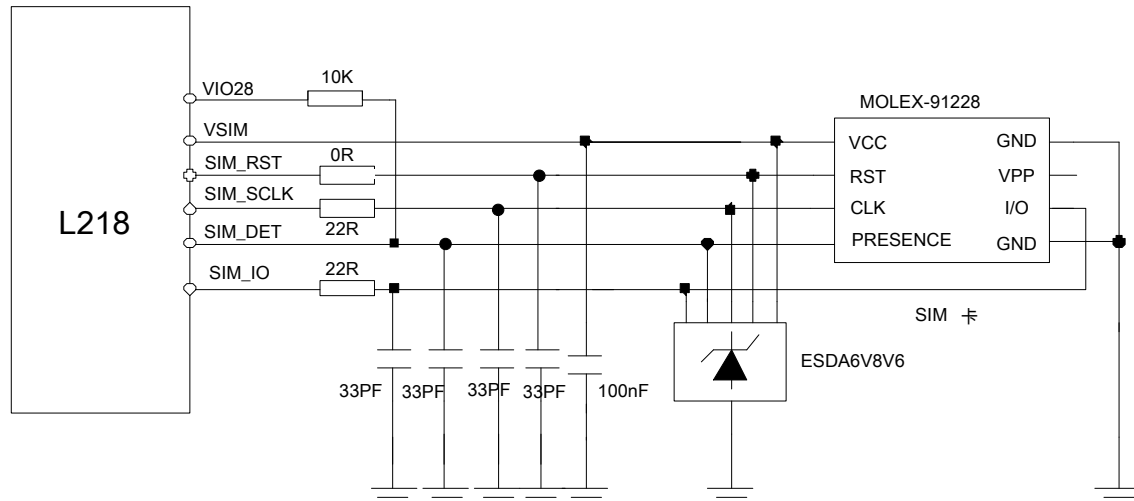
Below is a SIM card interface reference circuit, using 8 pin SIM gets stuck. SIM\_DET pins for Molex SIM booth detection. When cato is inserted into the booth, SIM\_DET into a low level. At this time whether or not a SIM card inside the cato, SIM\_DET level from high to low make initialization module produces a SIM card. By default, the SIM card detection is off, you can use the "AT + ESIMS = 1" to open or "AT + ESIMS = 0" to close the function. Learn more about the content of the AT command, please refer to the document [AT\_DOCUMENT].

When sending the " AT+CPIN?" the order, if not SIM card into the booth, can appear the URC information below:

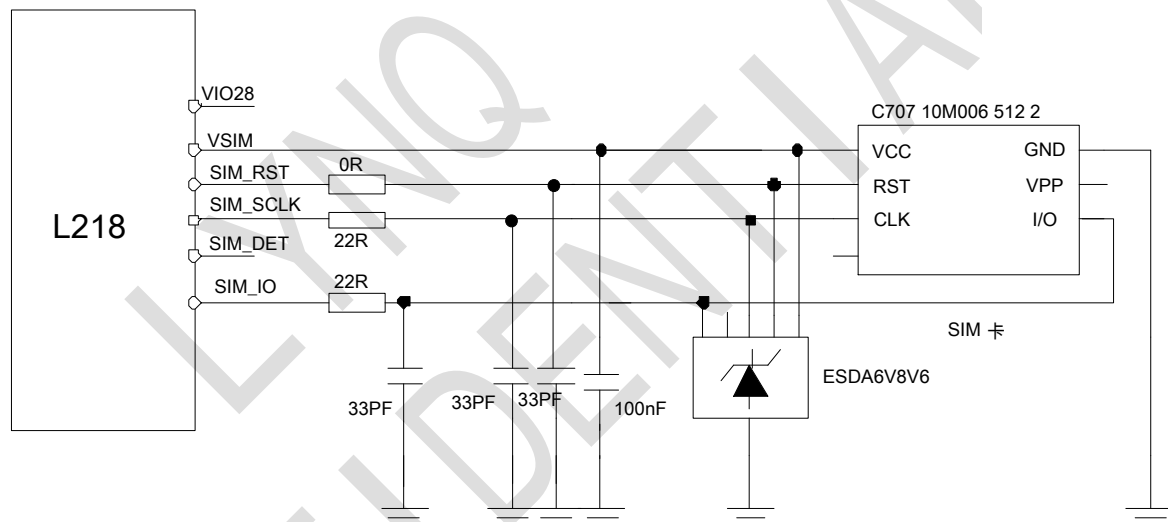
**+CPIN: NOT READY**

If the SIM card has been done into the booth, SIM initialized, the URC information will appear as below:

**Call Ready**



**Figure 3-25:** 8-pin SIM card (Reference circuit)



**Figure 3-26:** 6-pin SIM card (Reference circuit)

SIM card each signal need to increase the ESD protection devices used for ESD protection. In circuit design, in order to ensure the good performance of SIM card and is not damaged, in circuit design advice follow the following principles:

1. SIM gets stuck close to the module put, keep SIM card signal wiring less than 100 mm.
2. SIM card signal cable wiring away from the RF line and VBAT power line.
3. SIM gets-stuck and module of SIM\_GND wiring to short and thick. SIM\_VDD and SIM\_GND wiring width ensure that not less than 0.5 mm, and between SIM\_VDD and GND bypass capacitor does not exceed 1uf, and close to put SIM gets-stuck.
4. In order to prevent and SIM\_DATA SIM\_CLK signal crosstalk mutually, both wiring can't stand too close to, and between two linear increase shielding. In addition, SIM\_RST signal also

need to protect.

5. In order to ensure good ESD performance, it is recommended that the SIM card pin increase TVS diode. Choose the TVS diode parasitic capacitor is not more than 50 pf, for example: WILL ESDA6V8AV6 (<http://www.willsemi.com>). Series between the module and SIM card need to 22 ohm resistance to suppress stray EMI and ESD protection. SIM card of peripheral devices should be placed near the SIM holder.

6. Suggest SIM\_DATA, SIM\_RST SIM\_CLK and SIM\_VDD online parallel 33 pf capacitor is used to filter out radio frequency interference, and close to put SIM gets-stuck.

### 3.4.2 SIM gets stuck (Reference Figure)

SIM card connector 8 pin recommended Molex 91228. Please visit the <http://www.molex.com> website for more information!

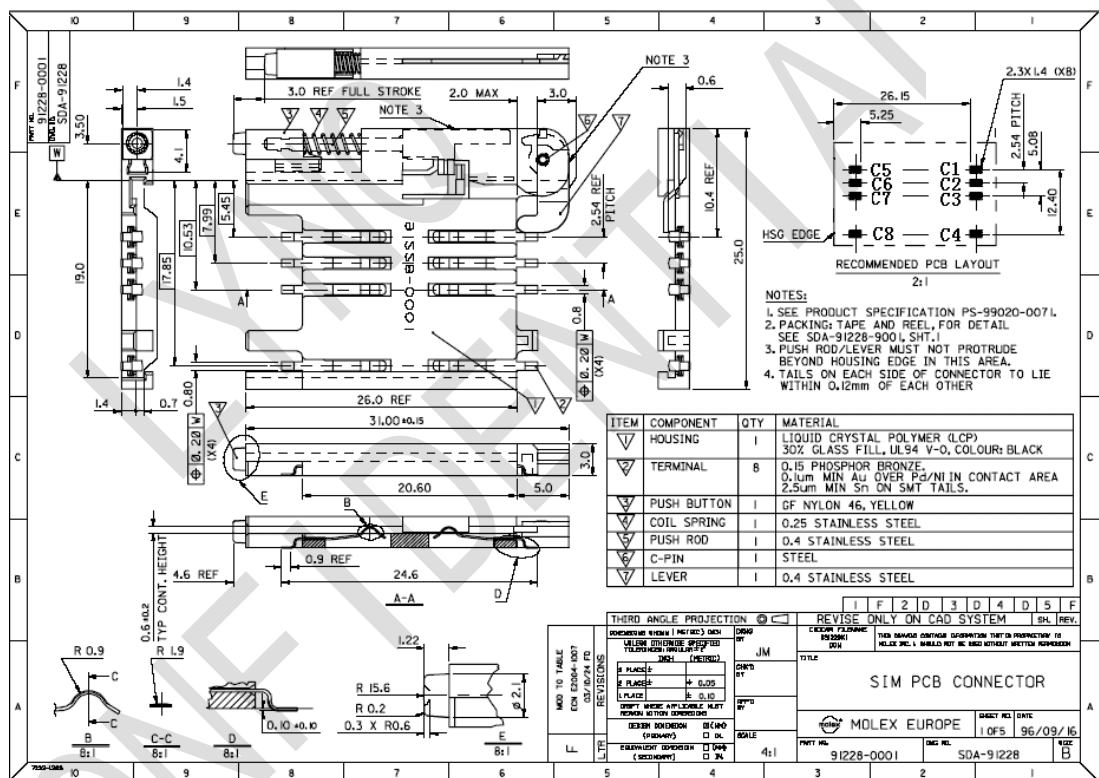


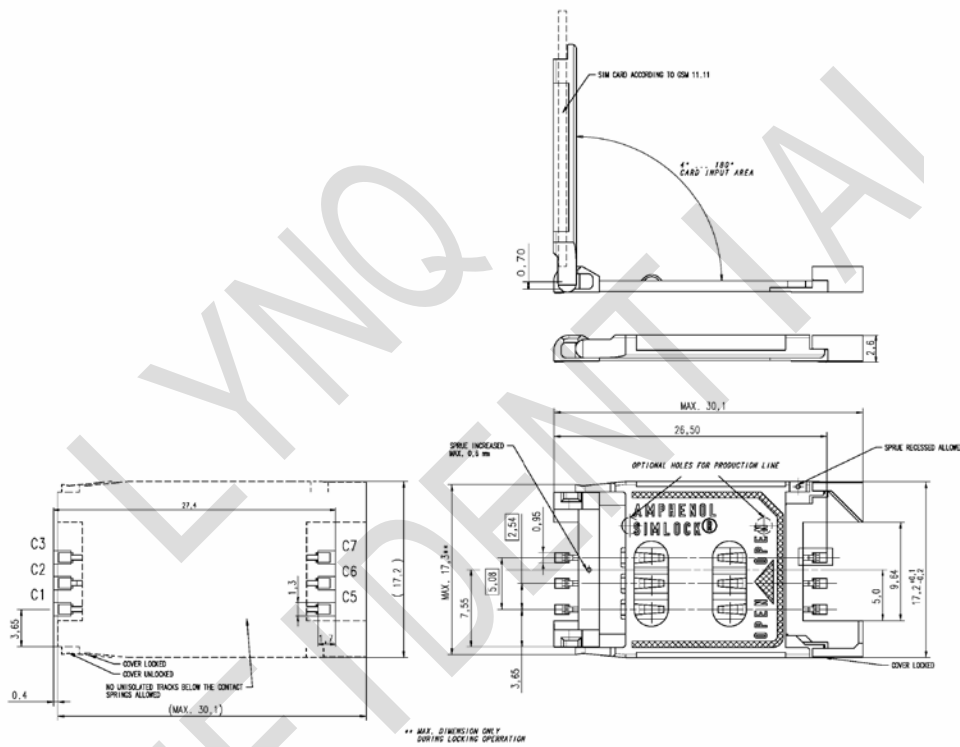
Figure 3-27: Molex 91228 SIM gets stuck

Table 9-6: PIN description (Molex SIM gets stuck)

PIN name	Signal	Description
C1	SIM_VDD	SIM card power supply pin
C2	SIM_RST	SIM card reset
C3	SIM_CLK	SIM card clock

C4	SIM_PRESENCE	SIM card detect pin
C5	GND	GND
C6	VPP	Not connected
C7	SIM_DATA	SIM card data input/output
C8	SIM_DETECT	Card SIM in position detection, the pin is directly connected to the ground, with the use of SIM_PRESENCE. When the SIM card tray is inserted, C4 and C8 are short circuit.

6 pins SIM booth is recommended to use Amphenol company C707 m006 10 5122. Please visit <http://www.amphenol.com> for more information!



**Figure 3-28:** Amphenol C707 10M006 5122 SIM gets stuck

**Table 10-7:** PIN description (Amphenol SIM gets stuck)

PIN name	Signal	Description
C1	SIM_VDD	SIM card power supply pin
C2	SIM_RST	SIM card reset
C3	SIM_CLK	SIM card clock
C5	GND	GND
C6	VPP	Not connected
C7	SIM_DATA	SIM card data input/output

### 3.5 PWM Interface

**Table 11-8:** PWM Pin definition

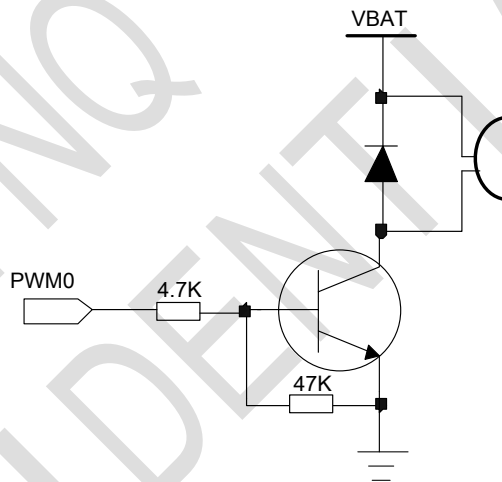
PIN NO.	PIN name	Description
14	PWM0	PWM signal, Reusable for GPIO2

PWM can provide the frequency range of 0~2KHz, the user can set the output frequency, duty cycle through the AT+SPWM command, please refer to the AT document.

PWM pin can be used to drive buzzer.

NOTE: Make sure the PWM pin keep low level when module in the boot process.

The reference circuit as follows:



**Figure 3-29:** PWM (Reference circuit)

### 3.6 NETWORK Status Indicator

**Table 12-9:** NETLIGHT pin definition

PIN NO.	PIN name	Description
29	NETLIGHT	Network status indicator

The NETLIGHT signal can be used to drive network status LED, the working state of this pin in the following table:

**Table 13-10:** working state of NETLIGHT

Light status	Work status
off	Power off
64ms on/ 800ms off	No Network
64ms on/ 3000ms off	Register to network
64ms on/ 300ms off	GPRS Data Communication

Reference circuit:

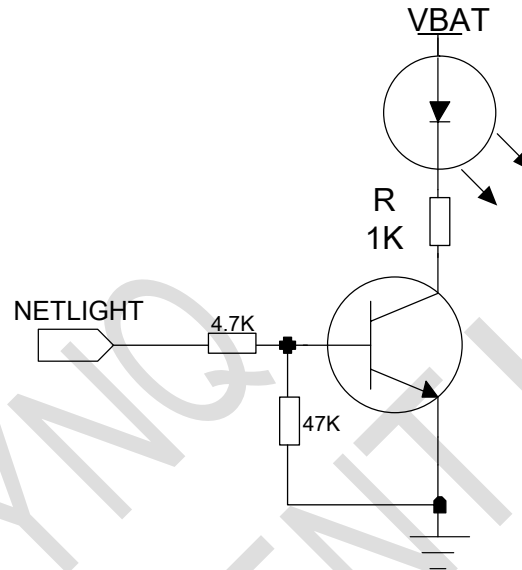


Figure 3-30: NETLIGHT (Reference circuit)

### 3.7 ADC Interface

L218 provides an ADC channel, the user can use the AT command "AT + CADC" to read voltage value on ADC pin. Note: the ADC sampling the voltage cannot be more than 2.8 V, otherwise easy to cause damage to the ADC. About the AT commands related information please refer to the document [AT\_DOCUMENT]. In order to improve the accuracy of ADC, the layout of ADC should be surrounded by ground.

Table 14-11: ADC interface pin definition

PIN NO.	PIN name	Description
30	ADC	Analog sampling

Table 15-12: ADC Parameter

Item	Min	Typ.	Max	Units
Input voltage range	0	-	2.8	V
ADC resolution	-	10	-	bits
ADC sampling rate	-	-	1.0833	MHz
ADC precision		10	30	mV

### 3.8 GNSS and BT Function

L218 supports GNSS and Bluetooth, users only need external matching GNSS antenna and Bluetooth antenna can be convenient to use this feature.

Can use AT commands through the serial port to the GNSS operation, in order to realize positioning, and other functions.

Can use AT commands through the serial port to the Bluetooth operation, in order to realize the external hands-free devices, set with matching, data transmission, and other functions.

For related the AT command [AT\_DOCUMENT] please refer to the document.

### 3.9 Antenna Interface

L218 interface provides three antenna, GSM antenna interface RF\_ANT respectively, and the GNSS antenna interface GPS\_RF ANT\_BT Bluetooth antenna and interface.

GNSS antenna, GSM antenna, BT antenna working in choose all needs to choose frequency band input impedance of 50 ohm, standing wave coefficient is less than 2 antenna products.

As far as possible away from two kinds of antenna is placed.

Each port antenna and other port isolation ratio should be greater than 30 db.

L218 provides three antenna interfaces, pin definition as below:

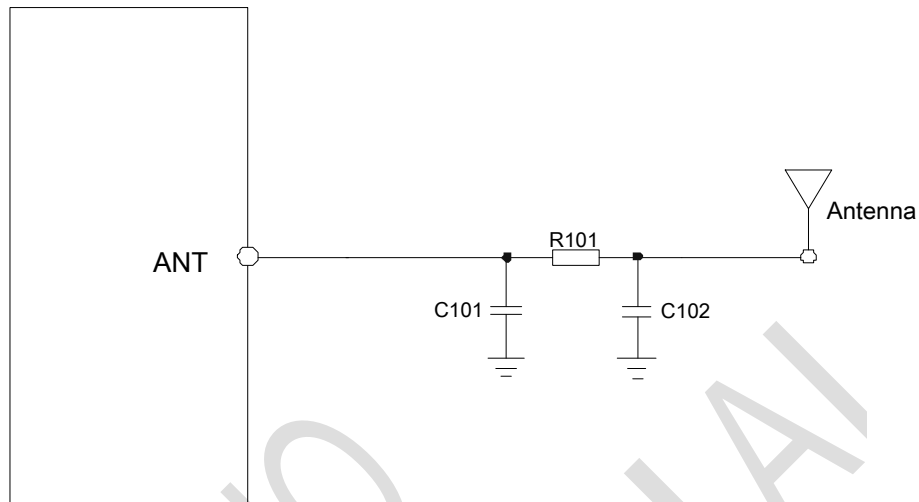
**Table 16-13:** Antenna interface pin definition

PIN NO.	PIN name	Description
40	GPS-ANT	GNSS antenna interface
20	RF_ANT	RF antenna interface
17	BT-ANT	BT antenna interface

#### 3.9.1 GSM and BT antenna reference circuit

For the peripheral circuit design of the antenna interface, in order to better adjust the RF

performance, the proposed reservation matching circuit. Antenna connection reference circuit as shown below. Where C101, C102 default is not posted, only 0 ohm R101 resistance, the line needs to be controlled by 50 ohm.



**Figure 3-31:** RF reference circuit (GSM/BT)

Component placement and RF routing takes note:

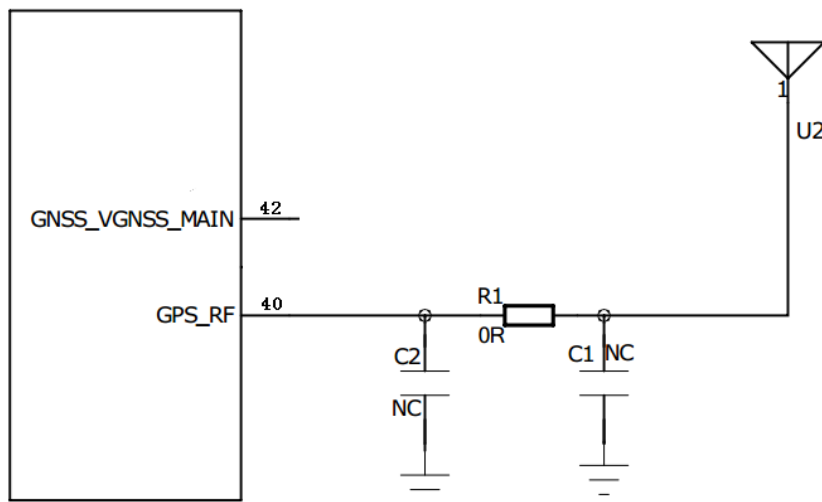
- Matching circuit must be placed near the antenna
- RF ANT foot to the antenna RF cable must be 50 ohm impedance control
- RF\_ANT PIN to antenna RF line must be far away from the high speed signal lines and strong interference sources, to avoid any signal lines cross or parallel and adjacent layer

### 3.9.2 GNSS antenna reference circuit

For the outside of the antenna interface circuit design, in order to better adjust the RF performance, suggest the reserved matching circuit. GNSS antenna can be divided into passive and active antenna, the antenna connection reference circuit as shown in the figure below.

#### a. Passive antenna

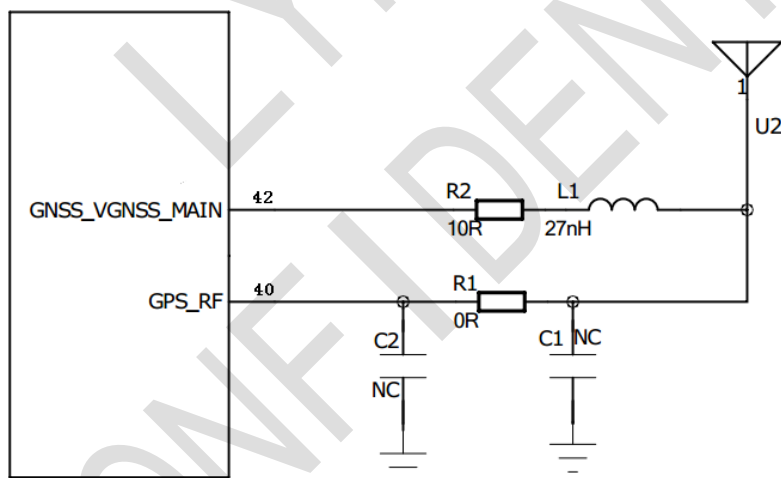
Matching circuits of C1 and C2 default don't stick, Resistor R1 only 0 ohm, need to get the line control according to 50 ohms.



**Figure 3-32:** GPS passive antenna (Reference circuit)

### b. Active antenna

Active antenna is integrated with built-in LNA, need plus 2.8 V to 2.8 V, suggest 3.3 V power supply. Matching circuits of C1 and C2 default don't stick, R1 resistor only 0 ohm, need to get the line control according to 50 ohms.



**Figure 3-33:** GPS active antenna (Reference circuit)

Component placement and RF routing takes note:

- Matching circuit must be placed near the antenna
- RF ANT foot to the antenna RF cable must be 50 ohm impedance control
- RF\_ANT PIN to antenna RF line must be far away from the high speed signal lines and strong interference sources, to avoid any signal lines cross or parallel and adjacent layer

## 3.10 USB Interface

### 3.10.1 Pin description

This product has a high speed USB1.1 interface, support full - speed mode, a main processor (AP) and mainly through the USB interface for data transmission between modules. USB interface are defined as follows.

**Table 17-14:** USB interface pin definition:

NO.	PIN name	PIN NO.	Description
1	VBUS_VBUS	43	USB Power
2	USB_DM	44	USB Differential data D-
3	USB_DP	45	USB Differential data D+

### 3.10.2 Electrical characteristics

The USB interface module accords with USB1.1 specification and electrical properties. Support full - speed working mode. Main processor (AP) and the module of data between the interaction is mainly completed through the USB interface.

### 3.10.3 USB interface applied

USB bus is mainly used for data transmission, software upgrades, detection module program. Work under the mode of high - speed USB line, if you need to ESD design, must satisfy the junction capacitor value of ESD protection devices  $< 5$  pf, or larger junction capacitor will cause waveform distortion, affect the bus communication. Differential difference of the data line impedance should be controlled in  $90 \text{ ohm} + / - 10\%$ .



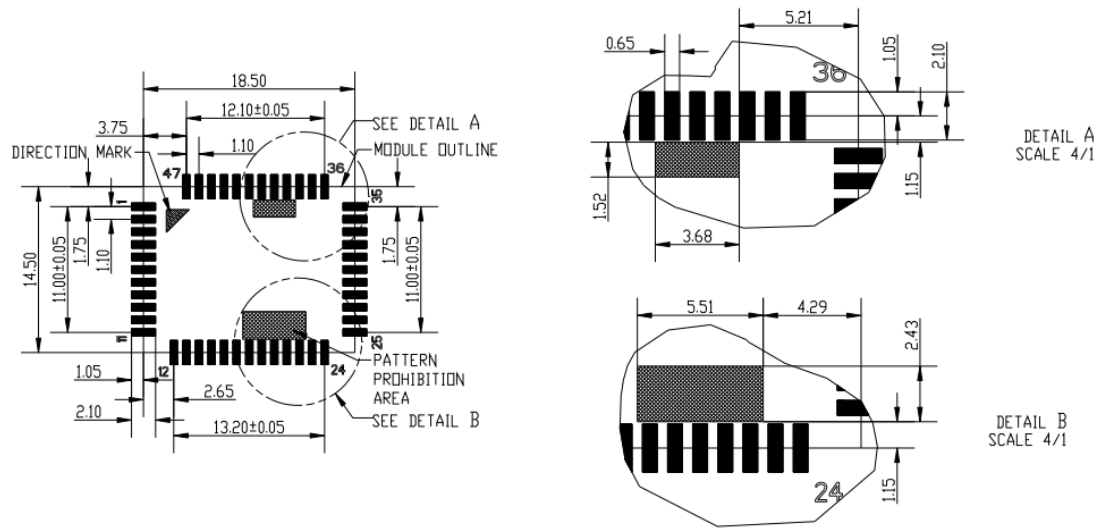


Figure 4-2: L218 Recommended Pad(mm)

CONFIDENTIAL

## 5 ELECTRICAL CHARACTERISTICS

### 5.1 Absolute Maximum Ratings

The following table shows the absolute maximum state in abnormal situation, more than the limit value will likely result in permanent damage to the module.

**Table 5-1:** Absolute Maximum Ratings

Parameter	Min	Max	Unit
VBAT	-0.3	4.4	V
Peak current	-0.3	2.5	A
Digital signal input voltage	-0.3	3.1	V
Analog input voltage	-0.3	3.1	V
Storage temperature	-45	+90	°C

### 5.2 Working Conditions

**Table 5-2:** Normal working conditions

Parameter	Min	Typ.	Max	Unit
VBAT	3.4	3.8	4.2	V
Working temperature	-40	25	+85	°C

### 5.3 Digital Interface Characteristics

**Table 5-3:** Digital Interface Characteristics

Parameter	Description	Min	Typ.	Max	Unit
VIH	Input high level	2.1	-	3.1	V
VIL	Input high level	0	-	0.7	V
VOH	Input high level	2.5	-	3.1	V
VOL	Input high level	0	-	0.3	V
VIH	Input high level	2.1	-	3.1	V

\* Apply to the GPIO, I2C, UART, PCM digital interface, etc.

## 5.4 VSIM Characteristics

**Table 5-4:** SIM card interface characteristics

Parameter	Description	Min	Typ.	Max	Unit
VO	Output voltage	1.65	1.8	1.95	V
		2.8	3.0	3.2	V
IO	Output current	-	-	60	mA

## 5.5 Current Consumption

**Table 5-5:** Current consumption

Parameter	Conditions	Min	Typ.	Max	Unit
Bottom current	Shutdown mode	--	0.15	--	mA
Working current	Sleep mode	--	1	--	mA
	Standby mode	--	10.6	--	mA
	Voice (maximum power)	--	280	--	mA
	Data transfer mode GPRS(1Rx,4Tx)	--	495	--	mA
Peak current	Data transfer mode GPRS(3Rx,2Tx)	--	413	--	mA
	Maximum power burst current	--	--	2.0	A
	Data transfer mode GPRS(3Rx,2Tx)	--	413	--	mA

## 5.6 ESD

In the use of the module, due to the human body static electricity, electric charge and friction between the two kinds of static electricity generated by various means of discharge to the module, may cause some damage, so ESD protection must pay attention, whether in the development, production assembly, testing process, especially in product design, should be taken to prevent ESD protection measures. Such as circuit design in the interface or vulnerable to the ESD point to increase the ESD protection, the production of anti-static gloves, etc.. Because the module is not specifically designed for electrostatic discharge protection, so in the production, assembly and operation module must pay attention to the electrostatic protection. The performance of the module test parameters in the following table:

ESD performance parameters (temperature: 25, humidity: 45%)

**Table 5-6:** ESD performance parameters

PIN	Contact discharge	Air discharge
VBAT	±5KV	±10KV
GND	±5KV	±10KV
RXD, TXD	±1KV	±6KV
RF_ANT	±5KV	±10KV
MIC_P/N	±2KV	±6KV
RCV_P/N		
PWRKEY	±3KV	±6KV
RESETB		

## 5.7 RF performance

- RF output power

Following table lists the conducted output power of modules, compliant with 3GPP TS 05.05 SPEC.

**Table 5-6:** EGSM900 and GSM850 conducted output power

PCL	Output power (dBm)	Tolerance (dB) for conditions	
	Nominal	Normal	Extreme
--			
5	32.5	±0.4	±2
6	30.8	±1	±2
7	29	±1	±2
8	27	±1	±2
9	25	±1	±2
10	23	±1	±2
11	21	±1	±2
12	19	±1	±2
13	17	±1	±2
14	15	±1	±2
15	13	±1.5	±2
16	11	±1.5	±2
17	9	±1.5	±2
18	7	±1.5	±5

**Table 5-7:** DCS1800 and PCS1900 conducted output power

PCL	Output power (dBm)	Tolerance (dB) for conditions	
		Normal	Extreme
--	Nominal		
0	29.5	±0.4	±2
1	27.5	±1	±2
2	26	±1	±2
3	24	±1	±2
4	22	±1	±2
5	20	±1	±2
6	18	±1	±2
7	16	±1	±2
8	14	±1	±2
9	12	±1.5	±2
10	10	±1.5	±2
11	8	±1.5	±2
12	6	±1.5	±2
13	4	±1.5	±2
14	2	±1.5	±5
15	0	±2	±5

- Module conduction receiver sensitivity

The following table lists the module's conduction reception sensitivity and is tested under static conditions.

**Table 5-8:** Conduction sensitivity

Band	Receiving sensitivity (Typ.)
GSM850	≅ -108dBm
EGSM900	≅ -108dBm
DCS1800	≅ -108dBm
PCS1900	≅ -108dBm

- Module frequency band

The following table lists the module's working frequency bands, compliant with the TS 3GPP 5.05 specification.

**Table 5-9:** Module frequency band

Band	Receiving sensitivity (Typ.)	Receiving sensitivity (Max))
GSM850	869 ~ 894MHz	824 ~ 849MHz

EGSM900	925 ~ 960MHz	880 ~ 915MHz
DCS1800	1805 ~ 1880MHz	1710 ~ 1785MHz
PCS1800	1930 ~ 1990MHz	1850 ~ 1910MHz

LYNQ  
CONFIDENTIAL

# 6 MANUFACTURING

This chapter describes the related information.

## 6.1 L218 Top And Bottom view

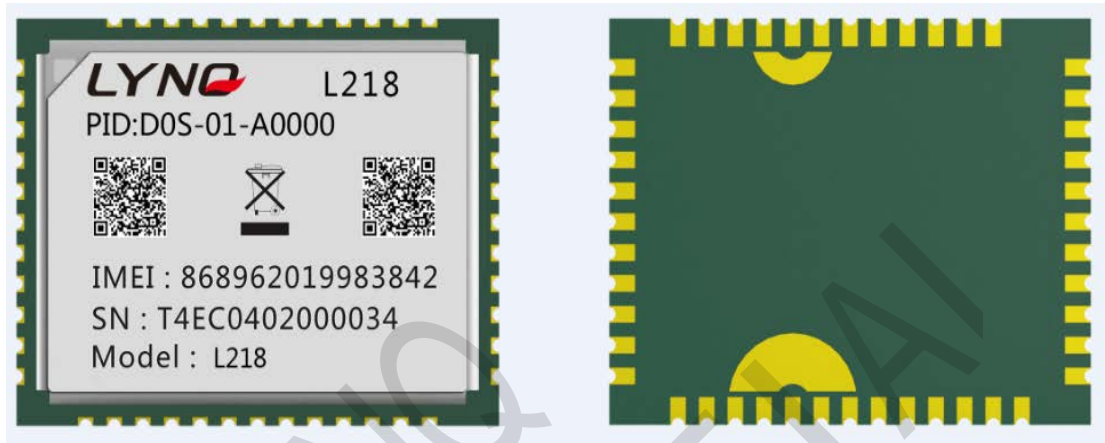


Figure 6-1: L218 top and bottom view

## 6.2 Soldering

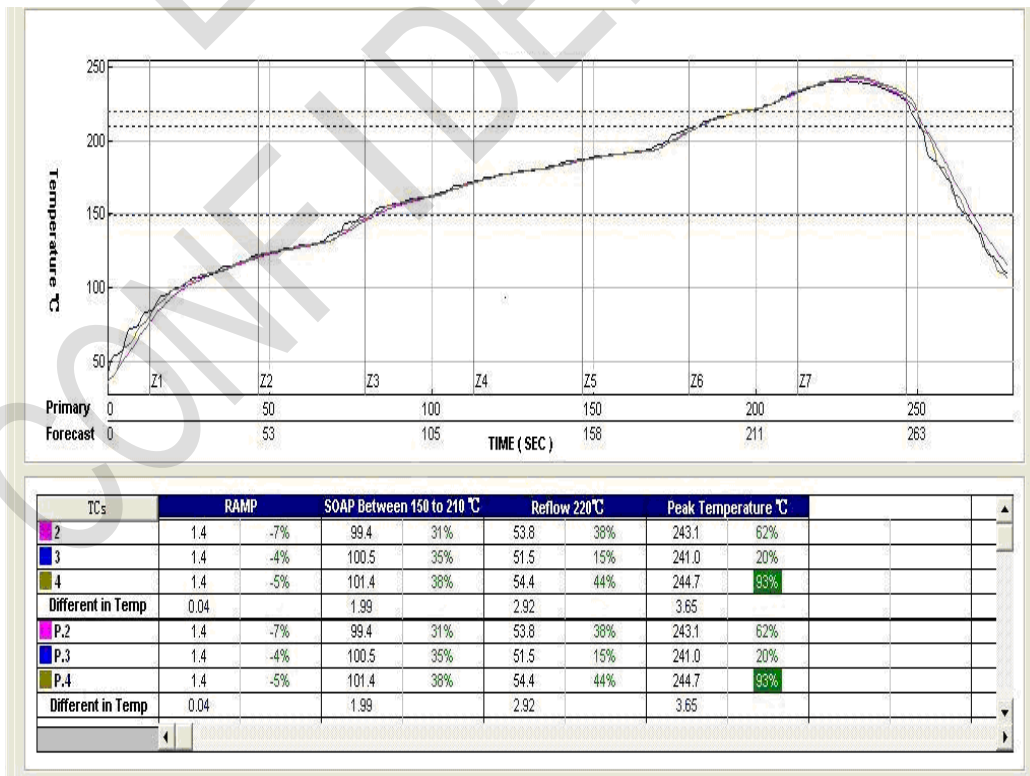


Figure 6-2: Recommend reflow temperature profile

## 6.3 The Moisture Sensitivity Level (MSL)

L218 module complies with the humidity level 3. At a temperature of <30 degrees and relative humidity of <60% of the environmental conditions, dry pack to perform J-STD-020C specification according to IPC / JEDEC standard. At a temperature of < 40 degrees and a relative humidity of < 90% of the environmental conditions, in the case of unopened shelf life of at least six months. After unpacking, Table29 shows the module shelf life at different times corresponding to the level of humidity.

**Table 6-1:** Moisture sensitivity level and floor life

The Moisture Sensitivity Level (MSL)	Floor Life(out of bag) at factory ambient $\cong$ +30 /60%RH
1 RH °C condition	Unlimited at $\cong$ +30 /85%
2	1 Year
2a	4 weeks
3	168 hours
4	72 hours
5	48 hours
5a	24 hours
6	Mandatory bake before use. After bake, it must be reflowed within the time limit specified on the label.

After unpacking, <30 degrees in temperature and relative humidity <60% environmental conditions, 168 hours in the SMT patch. If not meet the above conditions need to be baked.

NOTES: For product handling, storage, processing, IPC / JEDEC J-STD-020C must be followed

## 6.4 Baking Requirements

Due to the humidity sensitive characteristics of the L218 module, the L218 is a vacuum packaging, which can be stored for 6 months without damage to the package, and the ambient

temperature is less than 40 C and the relative humidity is less than 90%. To meet one of the following conditions, the process of reflow soldering should be performed before the full bake, or the module may cause permanent damage to the process.

- 1、 Vacuum packing damage or leakage
- 2、 The module is exposed in the air for 168 hours or more
- 3、 The module is exposed in air for 168 hours, not meet the temperature <30 degrees and relative humidity of the environment conditions <60%

**Table 6-2:** Baking requirements

<b>Baking temperature</b>	<b>Humidity</b>	<b>Baking time</b>
40° C±5° C	<5%	192 Hours
120° C±5° C	<5%	4 Hours

## 7 Package and Storage information

### 7.1 Package information

L218 module adopts by tape and reel. Shipping with the coil packaging and vacuum sealing anti-static bag to seal it.

#### 7.1.1 Tape and reel information

There are 500 L218 module assembled in a tape reel, below figure show the detail information.

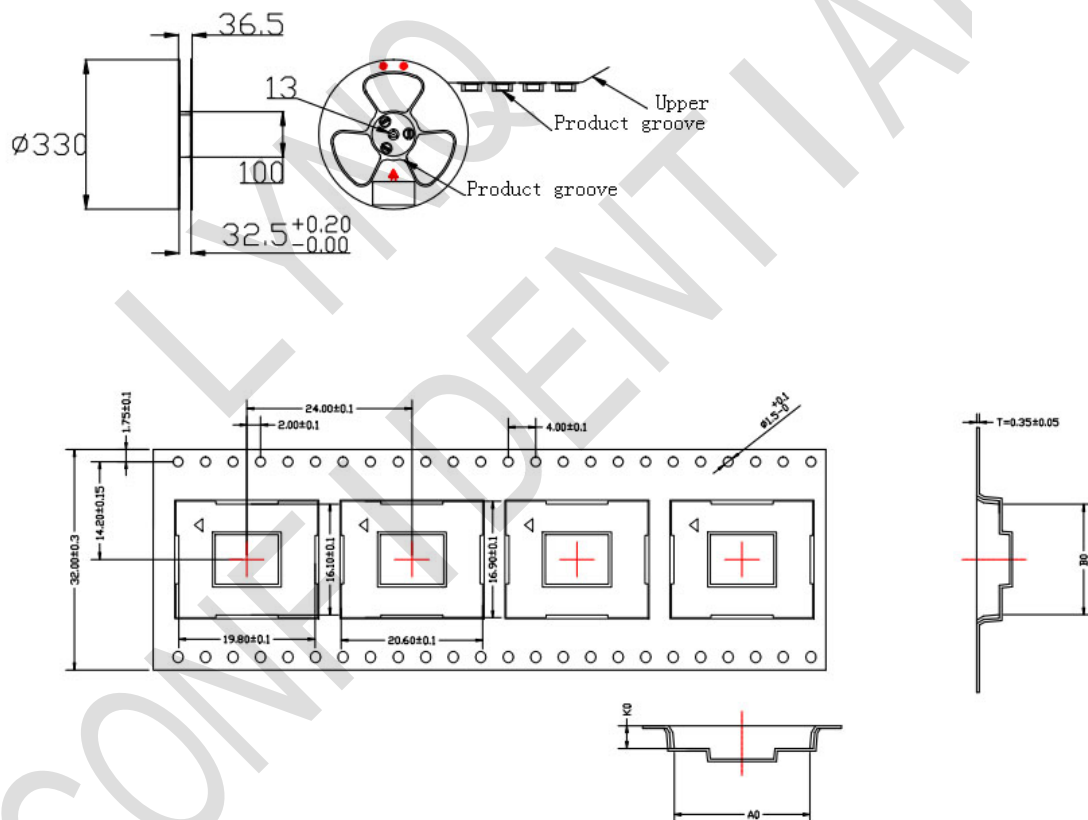
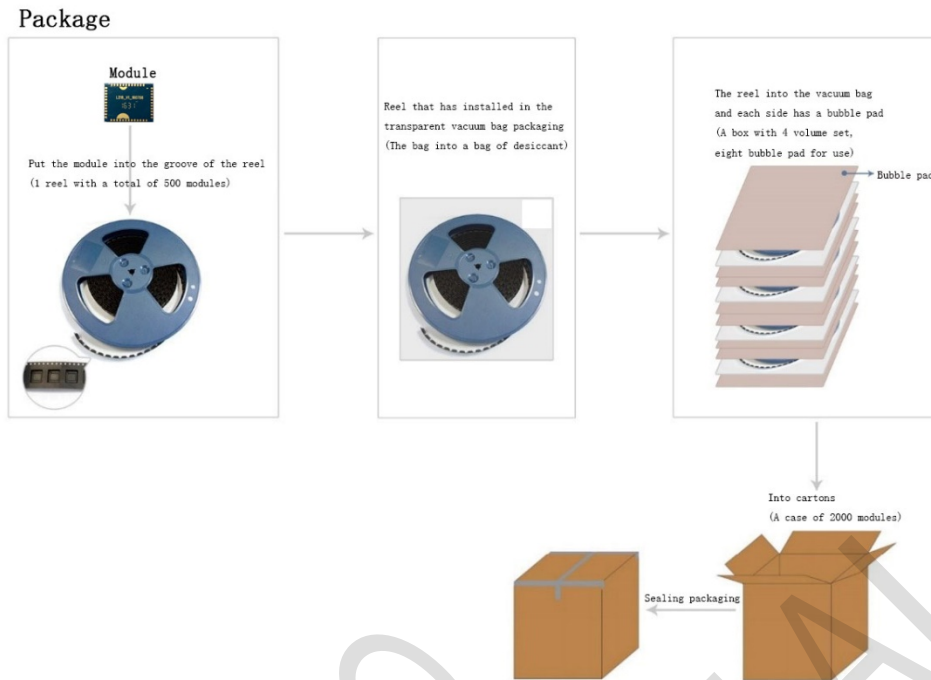


Figure 7-1: Tape and reel information

#### 7.1.2 Assemble and carrier information

L218 packing diagram is as follows, every 4 volumes of material packed in a case between each volume of material has a bubble mat do isolation protection. Specific as shown in the figure below:



**Figure 7-2:** Package and ship information

## 7.2 Bagged storage conditions

L218 shipments in the form of vacuum sealing anti-static bag. Module of storage need to follow the following conditions: Environment below 40 Degrees Celsius temperature, air humidity is less than 90% of cases, the module can be in vacuum sealed bags for 12 months. Conditions set the storage environment Suggestions with reference to the following form.

**Table 7-1:** Storage conditions (less than 90% humidity of the air vacuum sealed packaging)

Parameter	Min.	Typ.	Max.	Unit
Storage temperature	-45	25	90	°C

When on the vacuum bags, if meet the following conditions, the module can be directly for reflow soldering (furnace temperature setting reference 6.2 furnace temperature curve) or other high temperature process:

- Module temperature below 30 degrees c, the air humidity is less than 60%, factory within 72 hours to complete the SMT.
- The humidity is less than 10%.

If the module is in the following conditions, to be baked before SMT:

- When the environment temperature is 23 degrees Celsius (allow upper and lower volatility of 5 degrees Celsius), humidity index greater than 10%.
- When open vacuum bags, module temperature below 30 degrees Celsius, air humidity is less than 60%, but the factory have not finished the SMT within 72 hours.
- When open the vacuum bags, module storage air humidity is more than 10%.

If modules need baking, please under 125 degrees Celsius (allowing fluctuations of 5 degrees Celsius) up and down bake for 48 hours.

## 8 RELATED DOCUMENTS

**Table 8-1:** Related documents

NO.	Documents	Note
[1]	AT_DOCUMENT	
[2]	ITU-T Draft new recommendation V.25ter:	Serial asynchronous automatic dialing and control
[3]	GSM 07.07:	Digital cellular telecommunications (Phase 2+); AT command set for GSM Mobile Equipment (ME)
[4]	GSM 07.10:	Support GSM 07.10 multiplexing protocol
[5]	GSM 07.05:	Digital cellular telecommunications (Phase 2+); Use of Data Terminal Equipment – Data Circuit terminating Equipment (DTE – DCE) interface for Short Message Service (SMS) and Cell Broadcast Service (CBS)
[6]	GSM 11.14:	Digital cellular telecommunications system (Phase 2+); Specification of the SIM Application Toolkit for the Subscriber Identity Module – Mobile Equipment (SIM – ME) interface
[7]	GSM 11.11:	Digital cellular telecommunications system (Phase 2+); Specification of the Subscriber Identity Module – Mobile Equipment (SIM – ME) interface