

L306 Hardware Design

GSM/WCDMA Module Series

Version: V1.3

Date: 2016-11-10



Notice

Some features of the product and its accessories described herein rely on the software installed, capacities and settings of local network, and therefore may not be activated or may be limited by local network operators or network service providers. Thus, the descriptions herein may not exactly match the product or its accessories which you purchase. Shanghai Mobiletek Communication Ltd reserves the right to change or modify any information or specifications contained in this manual without prior notice and without any liability.

Copyright

This document contains proprietary technical information which is the property of Shanghai Mobiletek Communication Ltd. copying of this document and giving it to others and the using or communication of the contents thereof, are forbidden without express authority. Offenders are liable to the payment of damages. All rights reserved in the event of grant of patent or the registration of a utility model or design. All specification supplied herein are subject to change without notice at any time.

DISCLAIMER

ALL CONTENTS OF THIS MANUAL ARE PROVIDED "AS IS". EXCEPT AS REQUIRED BY APPLICABLE LAWS, NO WARRANTIES OF ANY KIND, EITHER EXPRESS OR IMPLIED, INCLUDING BUT NOT LIMITED TO, THE IMPLIED WARRANTIES OF MERCHANTABILITY AND FITNESS FOR A PARTICULAR PURPOSE, ARE MADE IN RELATION TO THE ACCURACY, RELIABILITY OR CONTENTS OF THIS MANUAL. TO THE MAXIMUM EXTENT PERMITTED BY APPLICABLE LAW, IN NO EVENT SHALL SHANGHAI MOBILETEK COMMUNICATION LTD BE LIABLE FOR ANY SPECIAL, INCIDENTAL, INDIRECT, OR CONSEQUENTIAL DAMAGES, OR LOSS OF PROFITS, BUSINESS, REVENUE, DATA, GOODWILL SAVINGS OR ANTICIPATED SAVINGS REGARDLESS OF WHETHER SUCH LOSSES ARE FORSEEABLE OR NOT.

Version History

Date	Version	Modify records	Author
2016-07-06	V1.0	First Release	Rc.dong,lb.xu
2016-07-29	V1.1	Modify HSPA Description	Lb.xu
2016-08-05	V1.2	Modify Band Support Description	Lb.xu
2016-11-10	V1.3	Modify error	Rc.dong

CONTENT

1. INTRODUCTION	5
1.1 HARDWARE DIAGRAM	5
1.2 MAIN FEATURES.....	5
1.3 SPECIFICATIONS	6
1.4 INTERFACES.....	7
2. PACKAGE INFORMATION	8
2.1 PIN CONFIGURATION	8
2.2 PIN DEFINITION.....	8
2.3 PACKAGE INFORMATION	13
2.3.1 Dimensions	13
2.3.2 Module size.....	14
2.3.3 Recommend Pad.....	16
3. INTERFACE CIRCUIT DESIGN	18
3.1 POWER SECTION	18
3.1.1 Power Supply	18
3.1.2 Power pin description	19
3.1.3 Hardware Power on.....	19
3.1.4 Hardware reset	19
3.2 USIM INTERFACE.....	20
3.2.1 Pin Description	20
3.2.2 USIM application	20
3.3 TF CARD INTERFACE	21
3.4 USB INTERFACE	22
3.5 PCM INTERFACE	23
3.6 IIC INTERFACE	24
3.7 SPI INTERFACE	24
3.8 UART INTERFACE.....	25
3.8.1 Pin Description.....	25
3.8.2 UART application	26
3.9 INTERACTIVE APPLICATION INTERFACE	28
3.10 LED INTERFACE	29
3.10.1 LED Control circuit	29
3.10.2 LED State description	29
4. ELECTRICAL CHARACTERISTICS	31
4.1 ELECTRICAL CHARACTERISTICS	31
4.2 TEMPERATURE CHARACTERISTIC	31
4.3 ABSOLUTE MAXIMUM POWER.....	32
4.4 RECOMMENDED OPERATING CONDITIONS	32
4.5 POWER SEQUENCE	33

4.6 DIGITAL INTERFACE CHARACTERISTICS	33
4.7 ESD	34
5. RF FEATURES	36
5.1 FREQUENCY BAND.....	36
5.2 DATA LINK.....	37
5.3 ANTENNA DESIGN	38
6. STORAGE AND PRODUCTION	41
6.1 STORAGE	41
6.2 PRODUCTION	41
6.2.1 Module confirmation and moisture	41
6.2.2 SMT reflow attentions	43
6.2.3 SMT stencil design and the problem of less tin soldering	44
6.2.4 SMT attentions.....	45

LYNQ
 CONFIDENTIAL

1. Introduction

L306 is a small UMTS/HSPA+ module for LCC package, with stable and reliable performance. It supports UMTS/HSDPA/HSUPA900(850)/2100(1900) and can be completely compatible with existing GSM/GPRS/EDGE networks.

1.1 Hardware Diagram

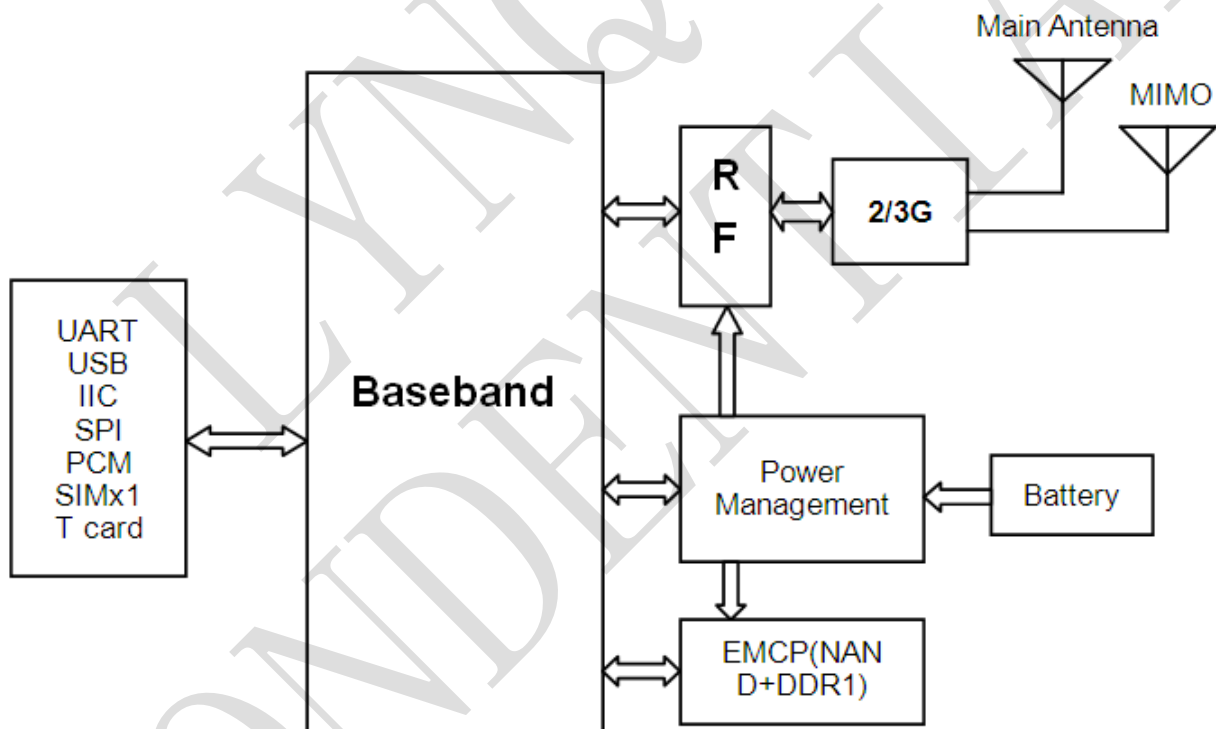

Figure 1-1 L306 functional architecture

1.2 Main features

- CPU

ARM Cortex-R4@481MHz

- **Flash**

RAM: 512Mb LPDDR1, 200 MHZ

Flash: 1Gb NAND

- **L306 series frequency bands**

Standard	Frequency	L306E	L306A	L306ME	L306MA	L306HE	L306HA
GSM	GSM850 MHZ	●	●	●	●	●	●
	EGSM900 MHZ	●	●	●	●	●	●
	DCS1800 MHZ	●	●	●	●	●	●
	PCS1900 MHZ	●	●	●	●	●	●
WCDMA	UMTS850 MHZ		●		●		●
	UMTS900 MHZ	●		●		●	
	UMTS1900 MHZ		●		●		●
	UMTS2100 MHZ	●		●		●	
HSPA	HSDPA ⁽¹⁾	●	●	●	●	●	●
	HSUPA ⁽¹⁾	●	●	●	●	●	●

(1)L306E(A)/L306ME(A)/L306HE(A) support different Version of HSPA , Please Reference Table 5-4

Data link.

1.3 Specifications

- Supply Voltage Range: 3.3~4.2V (type3.8V)
- Dimensions: 30mm * 30mm * 2.65mm
- Package: 94-pin LCC
- Operation Temperature Range: -40℃~+85℃
- Storage Temperature Range: -45℃~+90℃

- Antenna: Main Antenna、 Diversity Antenna
- Weight : Approx 5g

1.4 Interfaces

- SDIO
- SPI
- IIC
- PCM: Digital audio interface
- SIM: Support 1.8V/3V
- UART: High speed UART
- USB 2.0: High Speed ,480Mbps

LYNQ
CONFIDENTIAL

2. Package Information

2.1 Pin Configuration

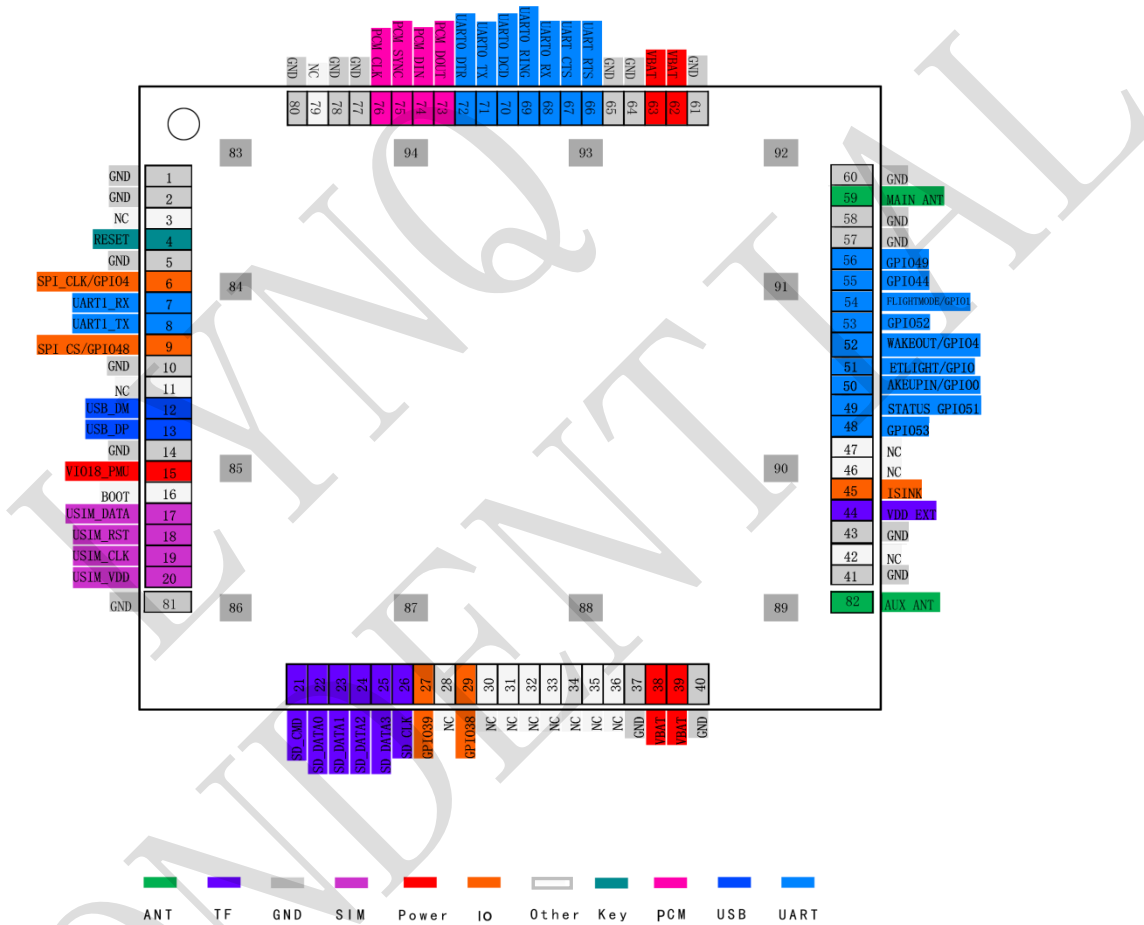

Figure 2-1 L306 PIN View

2.2 Pin definition

Table 2-1 Pin description

Pin NO.	Pin name	Type	Function Description	Power domain	State ⁽¹⁾
1.	GND	G	Ground		GND
2.	GND	G	Ground		GND
3.	NC		NC		
4.	SYRSTB	I	System reset signal	DVDD18	Open
5.	GND	G	Ground		GND
6.	GPIO47	I/O	General input/output PIN. It can be used as SPI clock	DVDD18	Open
7.	URXD1	I/O	UART1 RX	DVDD18	Open
8.	UTXD1	I/O	UART1 TX	DVDD18	Open
9.	GPIO48	I/O	General input/output PIN. It can be used as SPI chip-select	DVDD18	Open
10.	GND	G	Ground		GND
11.	NC		NC		
12.	USB_DM	DIO	USB port differential data line		Open
13.	USB_DP	DIO			Open
14.	GND	G	Ground		GND
15.	VIO18	P	1.8V output voltage	1.8V	Open
16.	LPRDB	I/O	USB download key (Reserve)	DVDD18	Open
17.	USIM_DATA	I/O	USIM data	DVDD18	Open
18.	USIM_RESET	O	USIM reset	DVDD18	Open
19.	USIM_CLK	O	USIM clock	DVDD18	Open
20.	USIM_VCC	P	USIM output voltage	1.8/3.0V	Open
21.	SD_CMD	I/O	SD card command pin	DVDD28	Open
22.	SD_DAT0	I/O	SD card data pin	DVDD28	Open
23.	SD_DAT1	I/O		DVDD28	Open
24.	SD_DAT2	I/O		DVDD28	Open

25.	SD_DAT3	I/O		DVDD28	Open
26.	SD_CLK	O	SD card clock output	DVDD28	Open
27.	GPIO39	I/O	General input/output PIN	DVDD18	Open
28.	NC		NC		
29.	GPIO38	I/O	General input/output PIN	DVDD18	Open
30.	NC		NC		
31.	NC		NC		
32.	NC		NC		
33.	NC		NC		
34.	NC		NC		
35.	NC		NC		
36.	NC		NC		
37.	GND	G	Ground		GND
38.	VBAT	P	Power supply	3.3~4.2V	VBAT
39.	VBAT				VBAT
40.	GND	G	Ground		GND
41.	GND	G	Ground		GND
42.	NC		NC		
43.	GND	G	Ground		GND
44.	VMC_PMU	P	VMC_PMU output voltage for SD	2.8/3.0/3.1/3.3V	Open
45.	GPIO17	I/O	General input/output PIN. It can be used as LED control	DVDD18	Open
46.	NC		NC		
47.	NC		NC		
48.	GPIO53	I/O	General input/output PIN	DVDD18	Open
49.	STATUS/GPI O51	O	Output PIN as operating status indicating of module	DVDD18	Open

50.	WAKEUP IN/GPIO0	I/O	Host to set the module into sleep or wake up the module from sleep	DVDD18	Open
51.	NETLIGHT/G PIO54	O	Output PIN as LED control for network status	DVDD18	Open
52.	WAKEOUT/G PIO46	I/O	General input/output PIN. It can be used as wake signal to host from module	DVDD18	Open
53.	GPIO52	I/O	General input/output PIN	DVDD18	Open
54.	FLIGHTMOD E/ GPIO1	I	Input PIN as RF operating control	DVDD18	Open
55.	GPIO44	I/O	General input/output PIN. It can be used as IIC clock	DVDD18	Open
56.	GPIO49	I/O	General input/output PIN. It can be used as IIC data	DVDD18	Open
57.	GND	G	Ground		GND
58.	GND	G	Ground		GND
59.	MAIN_ANT	ANT	RF Main Antenna		Open
60.	GND	G	Ground		GND
61.	GND	G	Ground		GND
62.	VBAT	P	Power supply	3.3~4.2V	VBAT
63.	VBAT				VBAT
64.	GND	G	Ground		GND
65.	GND	G	Ground		GND
66.	UART0_RTS	DO	UART0 ready to receive	DVDD18	Open
67.	UART0_CTS	DI	UART0 clear to send	DVDD18	Open
68.	UART0_RX	DI	UART0 receive data input	DVDD18	Open
69.	UART0_RING	DO	UART0 ring indicator	DVDD18	Open
70.	UART0_DCD	DO	UART0 data carrier detect	DVDD18	Open
71.	UART0_TX	DO	UART0 transmit output	DVDD18	Open
72.	UART0_DTR	DI	UART0 Data terminal ready	DVDD18	Open
73.	PCM_DOUT	I/O	PCM I/F data out	DVDD18	Open

74.	PCM_DIN	I/O	PCM I/F data in	DVDD18	Open
75.	PCM_SYNC	I/O	PCM interface sync	DVDD18	Open
76.	PCM_CLK	I/O	PCM interface clock	DVDD18	Open
77.	GND	G	Ground		GND
78.	GND	G	Ground		GND
79.	NC		NC		
80.	GND	G	Ground		GND
81.	GND	G	Ground		GND
82.	AUX_ANT	ANT	MIMO Antenna		Open
83.	GND	G	Ground		GND
84.	GND	G	Ground		GND
85.	GND	G	Ground		GND
86.	GND	G	Ground		GND
87.	GND	G	Ground		GND
88.	GND	G	Ground		GND
89.	GND	G	Ground		GND
90.	GND	G	Ground		GND
91.	GND	G	Ground		GND
92.	GND	G	Ground		GND
93.	GND	G	Ground		GND
94.	GND	G	Ground		GND

(1) Suggested status when not in use.

Table 2-2 Pin type description

P:POWER	G:GROUND
I:INPUT	DI:DIGITAL INPUT

O:OUTPUT	DO:DIGITAL OUTPUT
ANT:ANTENNA	DIO:DIGITAL INPUT OUTPUT
NC:NOT CONNECT	

2.3 Package Information

2.3.1 Dimensions

The M1507 mechanical dimensions are described as following figure (Top view, Side view).

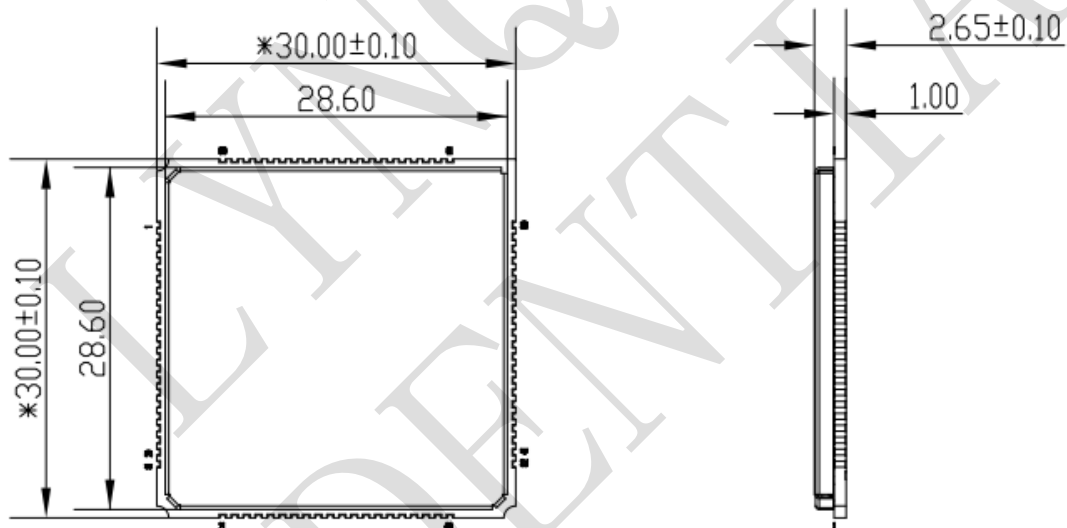
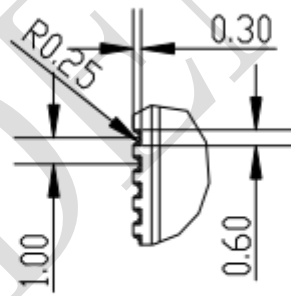
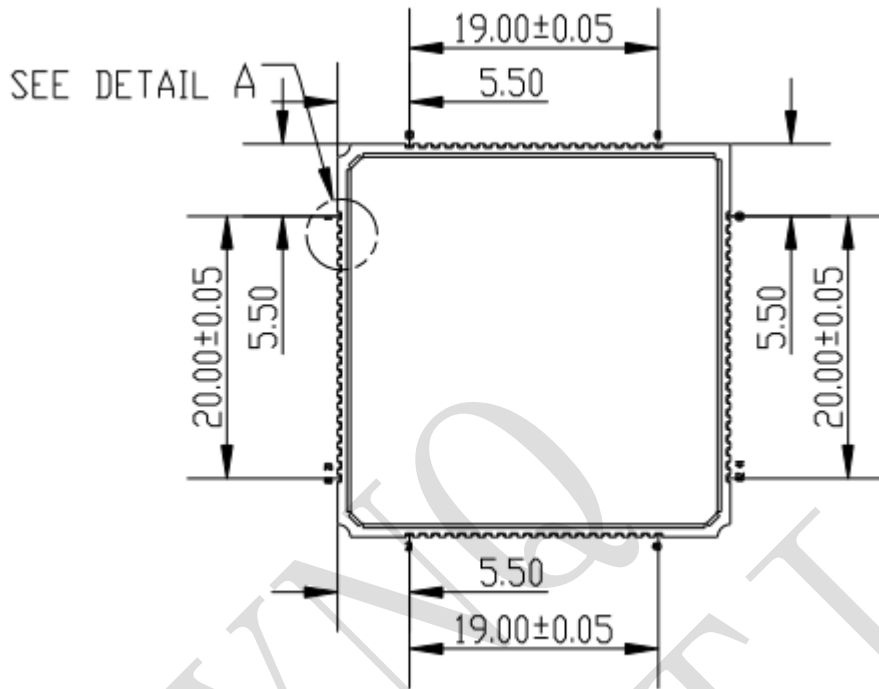

Figure 2-2 Mechanical Dimensions (Unit: mm)

2.3.2 Module size



DETAIL A
SCALE 2/1

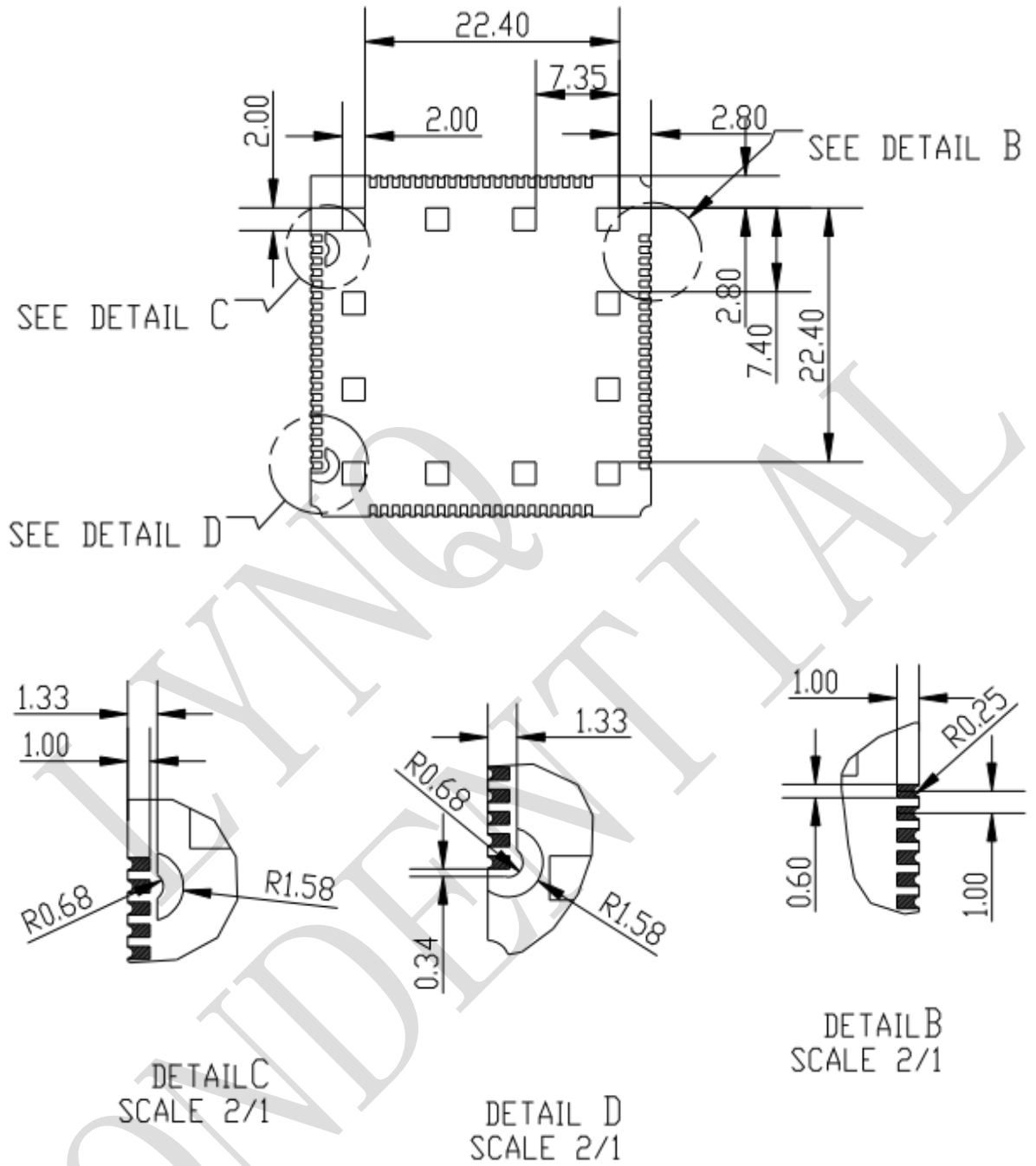
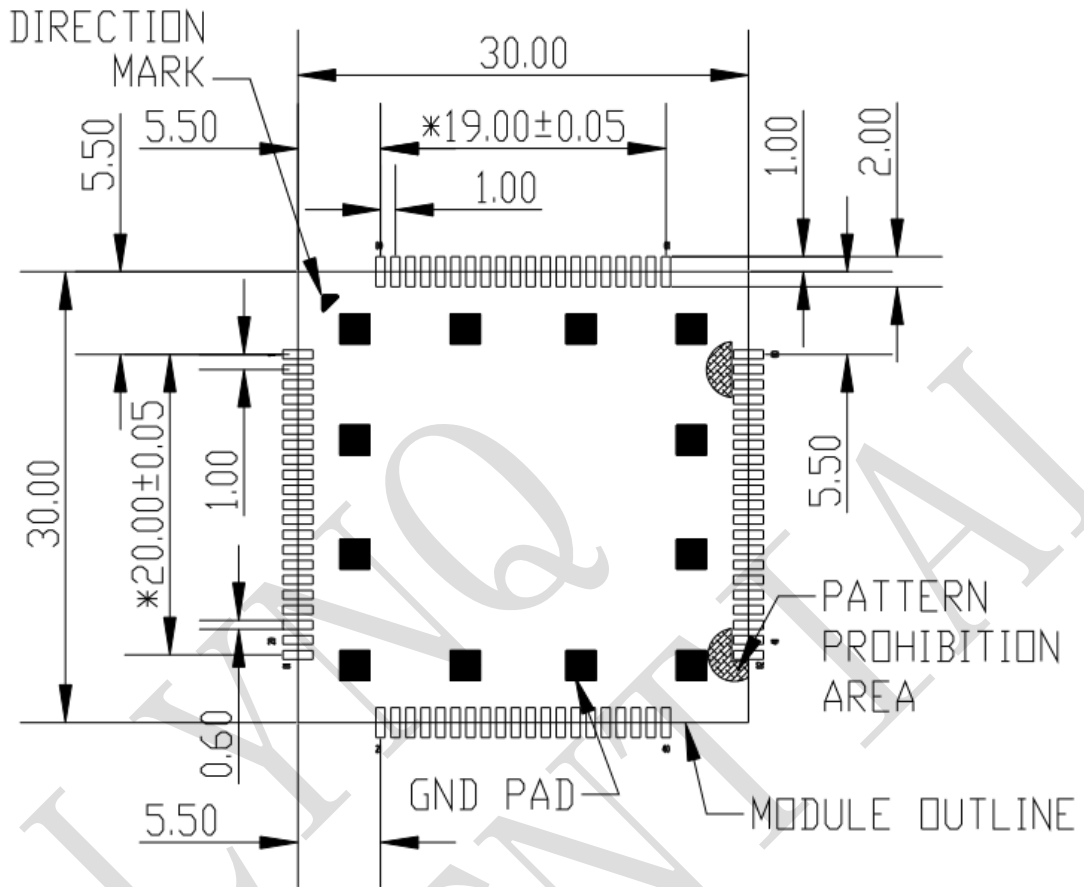

Figure 2-3 Module Size (back view)

2.3.3 Recommend Pad



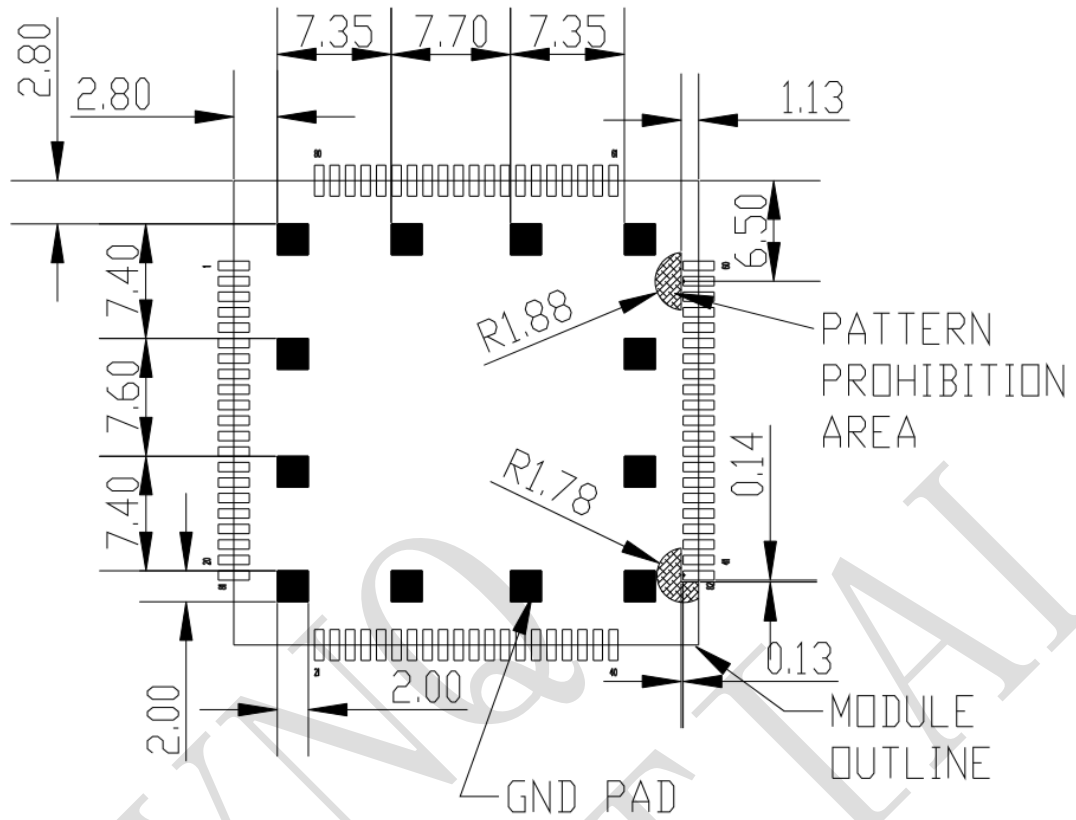

Figure 2-4 Recommend pad(front view)

3. Interface Circuit Design

3.1 Power Section

3.1.1 Power Supply

VBAT is the main power supply of the module, and the input voltage range is 3.3V to 4.2V. The recommended voltage is 3.8V. Because the module transmit burst may cause voltage drops, the highest peak will reach 2A. A large capacitor voltage is recommended to use near VBAT pins, and the capacitor's value is the bigger the better. In order to improve the continued flow of large current, it is recommended to use a low-impedance tantalum 470uF or larger. During layout, the capacitors are close to the VBAT pins.

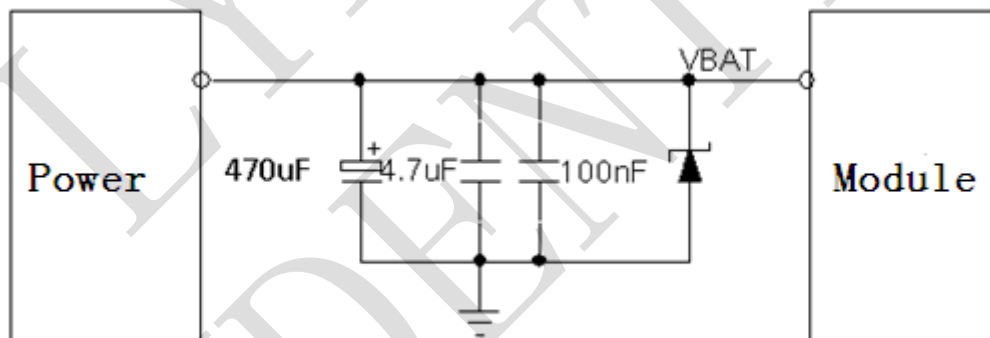

Figure 3-1 Power Supply circuit

Notes: According to the environment, please select capacitor as large value as possible; and add 100pF, 33pF capacitors if requiring.

Add Zener close to our module. The Zener should be 5.1V/500mW, $I_r < 100\mu\text{A}$
@ $V_r = 4.2\text{V}$. $T_a = 25^\circ\text{C}$.

3.1.2 Power pin description

Pin number	Pin name	Description
38/39/62/63	VBAT	positive signal
1/2/5/10/14/37/40/41/43/57/58/60/64/65 77/78/80/81	GND	GND
83/84/85/86/87/88/89/90/91/92/93/94	GND	GND

The Ground of power and signal need to be GND signal connection is not complete will have an impact on the performance of the product. In addition, there are a total of 12 (83~94) heat sink and fixed pad.

3.1.3 Hardware Power on

L306 module does not have a separate boot key, using the power on the boot form.

3.1.4 Hardware reset

Module fourth pin is the hardware reset input. The module will power off when it receives a 20ms low level signal. The system has an internal pull up, the typical value is 1.8V, and do not need to pull up externally.

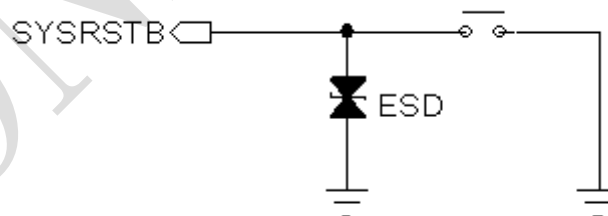

Figure 3-2 System Reset

3.2 USIM Interface

3.2.1 Pin Description

L306 supports and be able to automatically detect 3.0V and 1.8V USIM card. USIM card interface signal as shown in table 3-1.

Table 3-1 (U)SIM Pin Description

Pin NO.	Pin Name	Signal definition	Function Description
17	USIM_DATA	USIM card data pin	USIM card DATA signal, I/O signal
18	USIM_Reset	USIM card reset pin	USIM card reset signal, output by the module
19	USIM_CLK	USIM card clock pin	USIM card clock signal, output by the module
20	USIM_VCC	USIM output voltage	USIM card power supply, output by the module

3.2.2 USIM application

USIM card signal group (PIN number: 17, 18, 19, 20), near the USIM card seat on the line. Please note to increase the ESD protection device.

In order to meet the requirements of 3GPP TS 51.010-1 protocol and EMC certification, the proposed USIM card is arranged near the position module USIM card interface, and avoid to layout too long resulting in serious waveform distortion, affecting the signal integrity. USIM_CLK and USIM_DATA signals are recommended to be protected. Between GND and USIM_VCC in parallel with a 1uF and 33pF capacitors, that can filter out the interference of radio frequency signals.

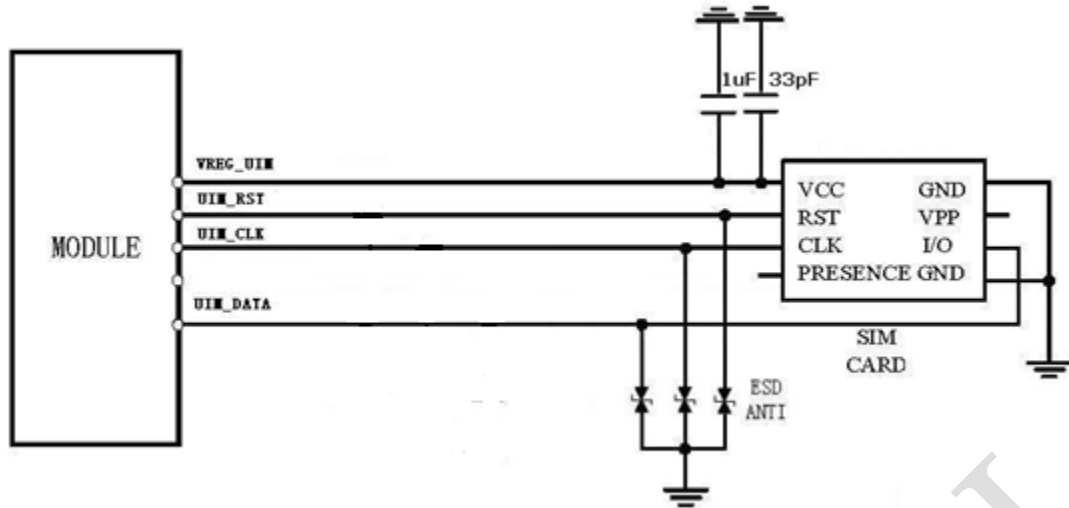

Figure 3-3 (U)SIM Circuit

3.3 TF Card Interface

Module supports SD card with 4 bit data interfaces, and supports SDIO2.0 protocol.

The ESD device is used to protect TF signal, and the ESD devices are placed near the TF seat. Both sides of SD_CLK signal must be protected by GND.

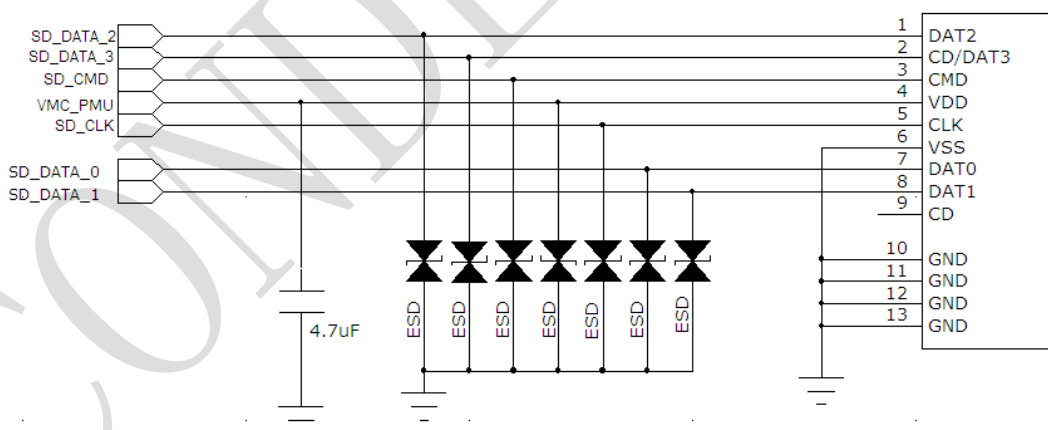

Figure 3-4 TF Circuit

Note: ESD $C_{pf} < 10\text{pF}$.

3.4 USB Interface

USB application

The USB interface of the module conforms to the USB2.0 specification and electrical characteristics. Support the low-speed, full-speed and high-speed three operating modes. The data exchange between the main processor (AP) and the module is mainly completed through the USB interface.

USB bus is mainly used for data transmission, software upgrade, module program testing. Working in the USB mode of the high-speed line, if you need ESD design, ESD protection devices must meet the junction capacitance value of $< 3\text{pf}$, otherwise the larger junction capacitance will cause waveform distortion, and affect the bus communication. The differential impedance of differential data lines should be controlled at $90\text{ohm} \pm 10\%$, and lines should be protected up and down, and can't be crossed with other lines. USB connection circuit is as follows.

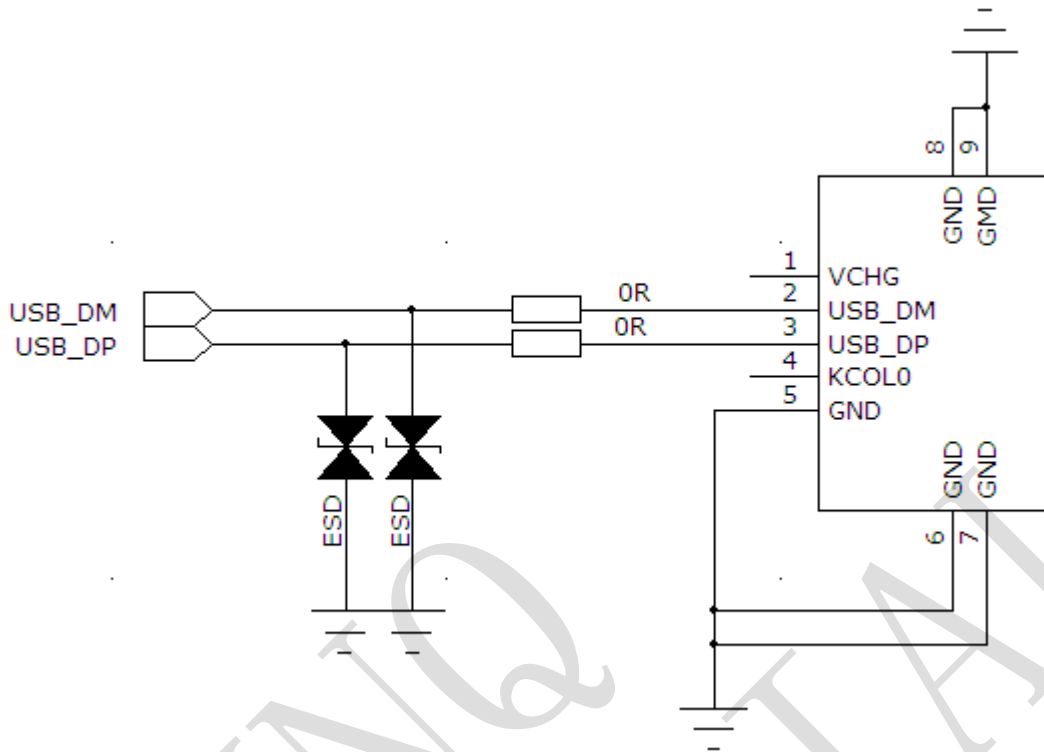

Figure 3-5 USB Circuit

3.5 PCM Interface

PCM application

L306 provides a digital audio interface (PCM) that can be used as a PCM master device to transmit digital voice signals. L306 only acts as a master device. PCM sync, PCM CLK are as output pins and PCM sync output 16kHz synchronization signals, the PCM data support 8-bit or 16 bit data format. We recommended codec chip is NAU8814YG. The codec chip crystal default use 1.8V power supply, 12M output active crystal. The power control pin of the PCM uses the PIN45 by default. And NAU8814YG connected circuit from the device is shown in figure 3-6.

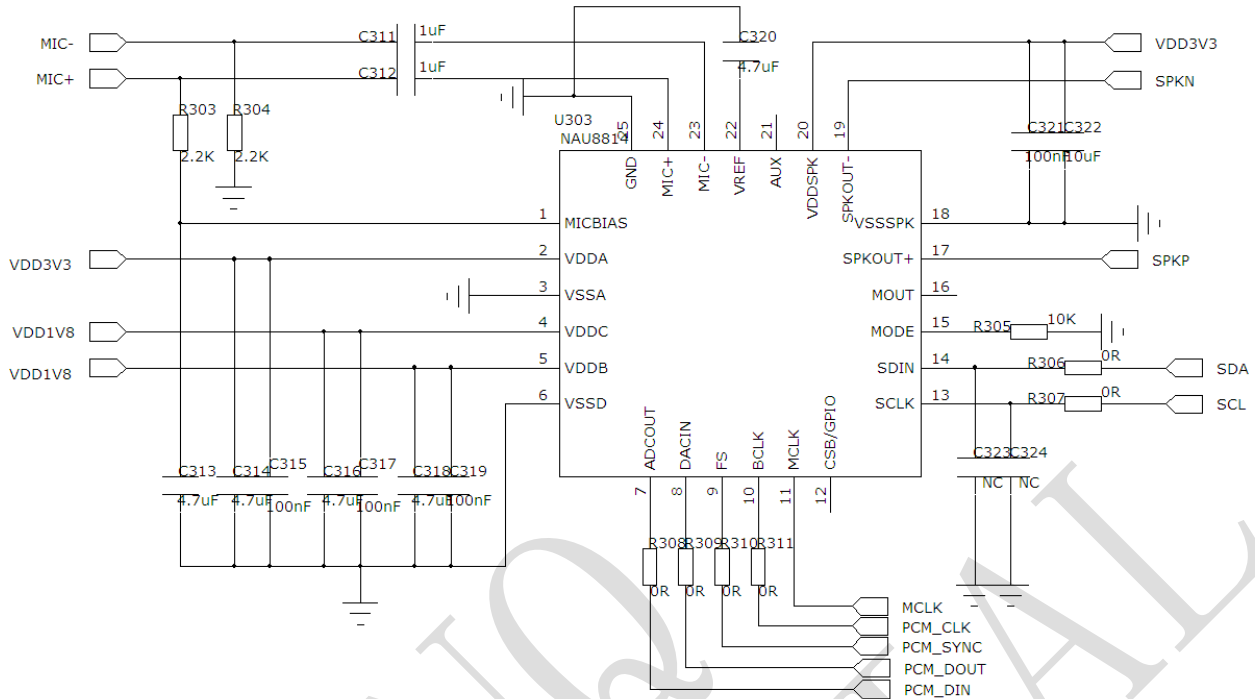

Figure 3-6 NAU8814YG peripheral Circuit (L306 as Main device)

3.6 IIC Interface

L306 module does not have a dedicated IIC interface. if you need to use the IIC interface for communication, you should use the GPIO port to simulate the IIC interface, and it is recommended to use an external pull-up resistor of 4.7K by VIO18.

3.7 SPI Interface

Module does not have a dedicated SPI interface. if you need to use the SPI interface for communication, you should use the GPIO port to simulate SPI interface. It only supports the main device model.

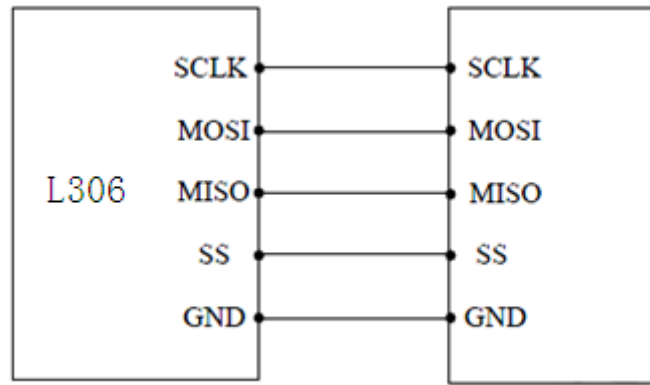

Figure 3-7 SPI Interface

Note: For SPI and IIC interface, the average power is 1.8V. If the external level standards are not the same, then you need to do level conversion. It is recommended to use the IC to change the level.

3.8 UART Interface

3.8.1 Pin Description

The module L306 provides two UART serial communication interfaces: the UART1 is as the end of the AP module debug port, 2-wire UART interface; UART0 can be debug port and also can be as complete non-synchronous communication interface, supporting standard modem handshake signal control and in compliance with the RS-232 interface protocol, also supporting 4-wire serial bus interface or 2-wire serial bus interface mode. The module can communicate by AT commands or UART interfaces.

The two groups of UART port support programmable data width, stop bits, and parity bits, with separate TX and Rx FIFOs (512 bytes each). The max baud rate of normal application of UART (non-Bluetooth) is 115200bps. The default baud rate is 115200bps.

Table 3-2 UART Pin Description

Pin NO.	Pin Name	I/O	Function Description
7	UART1_RX	I/O	UART1 receive data input only for debugging
8	UART1_TX	I/O	UART1 transmit output only for debugging
66	UART0_RTS	DO	UART0 Ready to receive
67	UART0_CTS	DI	UART0 Clear to Send
68	UART0_RX	DI	UART0 receive data input
69	UART0_RING	DO	UART0 Ring Indicator
70	UART0_DCD	DO	UART0 Data Carrier Detect
71	UART0_TX	DO	UART0 transmit data output
72	UART0_DTR	DI	Data Terminal Ready

3.8.2 UART application

UART0 and UART1 can be used for software debugging process. We suggest that the users retain this interface and set aside the test point.

If used in communication between the module and application processor, and the level is 1.8V, the connection mode is shown in Figure 3-8 and figure 3-9. You can use the complete RS232 mode, 4 wires or 2 wires mode connection. Module interface level is 1.8V. If the AP interface level does not match, you must increase the level conversion circuit.

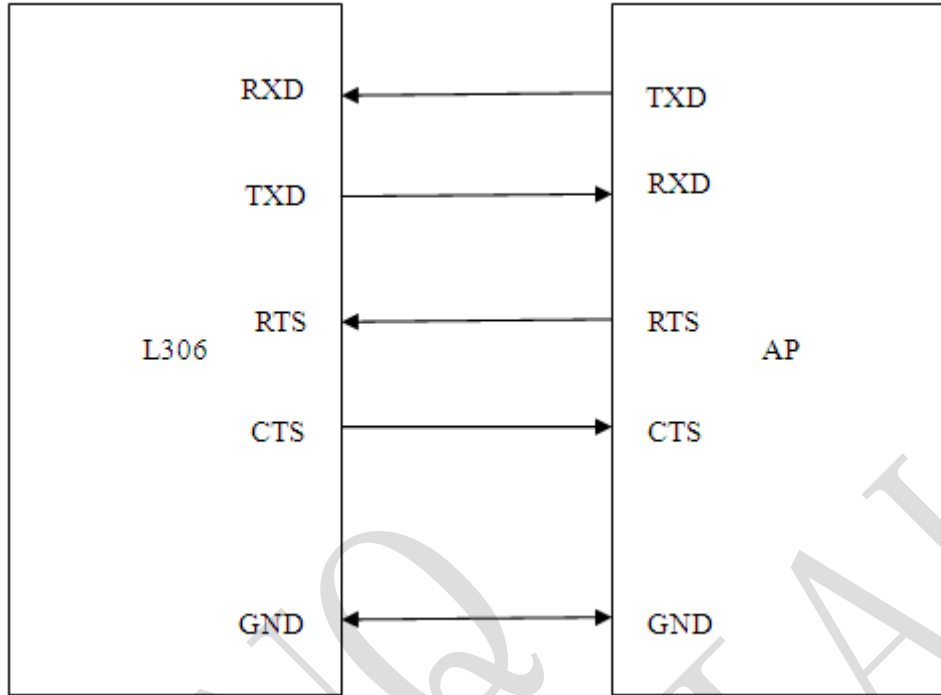

Figure 3-8 Connect to AP method(4lines)

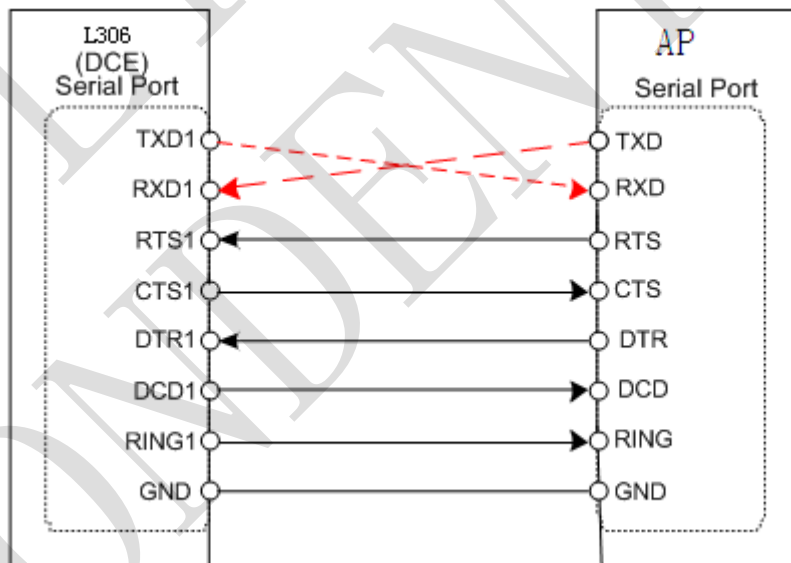

Figure 3-9 Connect to AP method

Notes: If you use the serial port communication, USB DM, DP reserved test points respectively in order to download software.

Serial communication, the module can enter the sleep; USB communication, the module can't enter the sleep, unplug the USB, the module can enter the sleep.

3.9 Interactive Application Interface

Pin Description

Table 3-3 Interactive application interface

Pin NO.	Pin name	I/O	Function Description
51	NETLIGHT/GPIO54	O	Output PIN as LED control for network status. If it is unused, left open
54	FLIGHT MODE/GPIO1	I	Input PIN as RF operating control. H: Normal Mode, L: Flight Mode. If it is unused, left open
49	STATUS/GPIO51	O	Output PIN as operating status indicating of module. H: Power on L: Power off. If it is unused, left open
52	WAKEOUT/GPIO46	I/O	General input/output PIN. It can be used as wake/interrupt signal to host from module If it is unused, left open
50	WAKEUP IN/GPIO0	I/O	General input/output Port. It can be used as wake/interrupt signal to module from host. If it is unused, left open

Note: If need to use more GPIO ports, you can refer to table 2-1; User can read and write GPIO port state through the AT command.

3.10 LED Interface

3.10.1 LED Control circuit

GPIO54 (PIN51) can be used to control the network status of the lam; GPIO17 (PIN45) can be used as an indicator of the power supply connected or not.

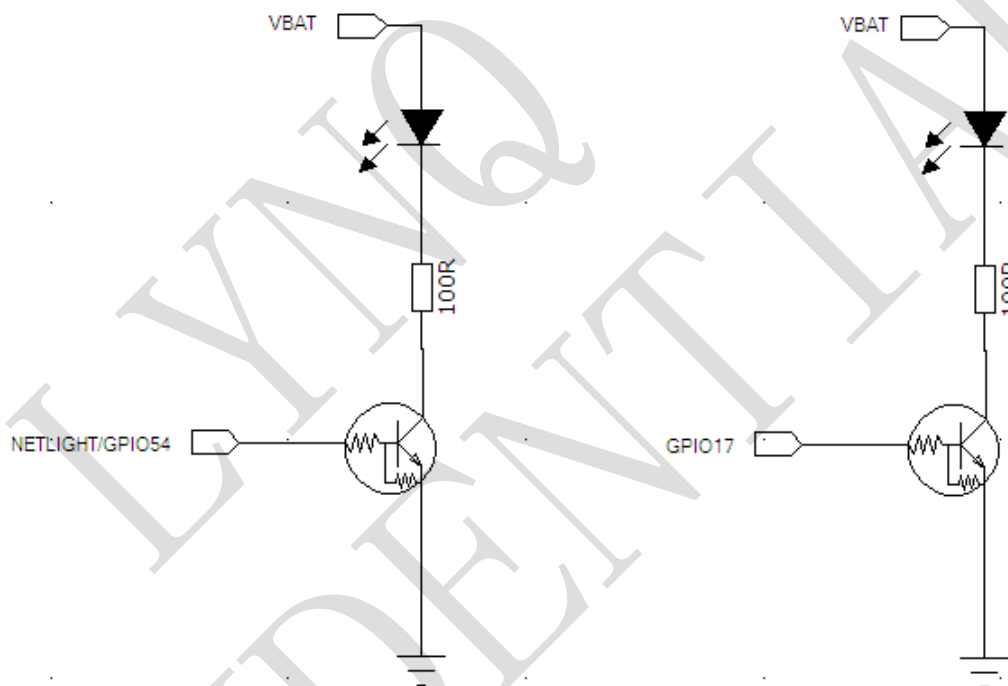

Figure 3-10 LED Circuit

3.10.2 LED State description

GPIO17 is used as the enable pin. Table 3-4 lists the LED status.

Table 3-4 LED Status

LED Status	Module Status
------------	---------------

Always On	Power on
OFF	Power off

GPIO54 is used as the enable pin. Table 3-5 lists the LED status.

Table 3-5 LED Status

LED Status	Module Status
Always On	Searching Network/Call Connect
200ms ON, 200ms OFF	Data Transmit
800ms ON, 800ms OFF	Registered network
OFF	Power off / Sleep

4. Electrical characteristics

4.1 Electrical characteristics

Table 4-1 Electrical characteristics

Power	Min.	Nom.	Max	Unit
VBAT	3.3	3.8	4.2	V
Peak current	-0.3	-	2.0	A

Notes: The over-low voltage can't power on the module; Over-high voltage may be danger to damage the module.

Using the DCDC supply, please ensure the capacity of DCDC over 2.0A. We don't suggest the LDO as the power supplier.

4.2 Temperature characteristic

Table 4-2 Temperature characteristic

State	Min.	Nom.	Max	Unit
Working	-40	25	85	°C
Storage	-45	25	90	°C

Note: When the temperature is over the range, the RF performance may be dropped. It also may cause power down or restart problem.

4.3 Absolute Maximum Power

Table 4-3 Absolute maximum power rating

PIN Name	Description	Min.	Typ.	Max.	Unit
DVDD18	Digital power input for IO	1.7	1.8	1.9	V
DVDD28	Digital power input for IO	2.65	2.8	3.5	V

4.4 Recommended operating conditions

Table 4-4 Recommended operating range

PIN Name	Description	Min.	Typ.	Max.	Unit
DVDD18	Digital power input for IO	1.7	1.8	1.9	V
DVDD28	Digital power input for IO	2.65	2.8	3.5	V

Note: All the GPIOs of module are 1.8V.

4.5 Power Sequence

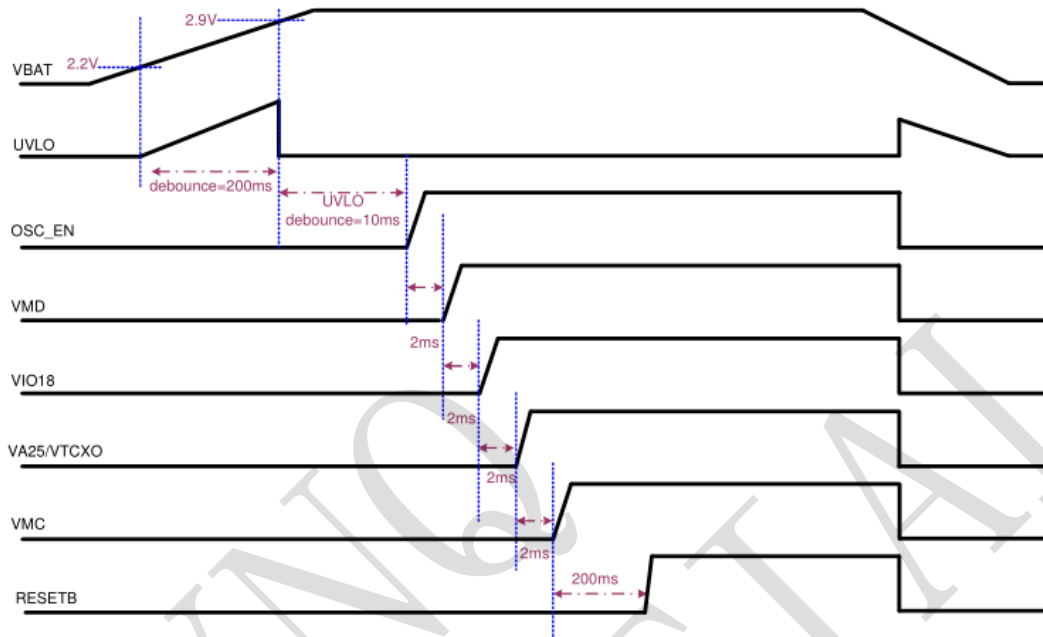

Figure 4-1 Power up time sequence diagram

4.6 Digital Interface Characteristics

Table 4-5 Digital IO Voltage

Parameter	Description	Min.	Typical	Max.	Unit
VIH	High level input voltage	1.62	1.8	1.98	V
VIL	Low level input voltage	0	-	0.7	V
VOH	High level output voltage	1.62	1.8	1.98	V
VOL	Low level output voltage	0	-	0.3	V

Note: Suit to all GPIO, IIC, UART, SPI interfaces.

4.7 ESD

Because there is no special protection against electrostatic discharge in the module, it is necessary to pay attention to the protection of electrostatic protection in the production, assembly and operation module. The performance parameters of the module test are as follows.

ESD parameter (Tem: 25°C, humidity: 45%) .

Table 4-7 ESD Performance

PIN Name	Contact discharge	Air discharge
VBAT	±4KV	±8KV
GND	±4KV	±8KV
RF_ANT	±4KV	±8KV

Enhanced ESD performance method:

- 1、 If the customer to the adapter plate, the adapter plate anchor as much as possible, and the uniform distribution of conduction path width;
- 2、 The suspension plate (key board or light board, etc.) need to be well grounded, for grounding copper exposure;
- 3、 Key (reset key) need to add ESD device; reset key to walk the line do not rely on the edge of the board;
- 4、 USB, UART and other plug connection need to add ESD devices, the other from the outside of

the machine out of the control line also need to add ESD devices;

- 5、 SIM card, users will get inserted t-card touch the place also need to add ESD device;
- 6、 External antenna, please add ESD device, ESD $C_{pf} < 0.5\text{pF}$.

Notes: For ESD protect, please add ESD methods according to upper ways.

High speed circuits like USB, TF and SIM card should be added ESD with low capacity value.

ESD components include varistors and TVS. For better performance, please use TVS.

5. RF Features

5.1 Frequency Band

L306 supports GSM Band 2/3/5/8 and WCDMA Band1(2)/Band8(5).

Table 5-1 Frequency Bands

Frequency	Uplink	Downlink
GSM850	824 MHz — 849 MHz	869 MHz — 894 MHz
E-GSM900	880 MHz — 915 MHz	925 MHz — 960 MHz
DCS1800	1710 MHz — 1785 MHz	1805 MHz — 1880 MHz
PCS1900	1850 MHz — 1910 MHz	1930 MHz — 1990 MHz
UMTS2100	1920 MHz — 1980 MHz	2110 MHz — 2170 MHz
UMTS1900	1850 MHz — 1910 MHz	1930 MHz — 1990 MHz
UMTS850	824 MHz — 849MHz	869 MHz — 894 MHz
UMTS900	880 MHz — 915 MHz	925 MHz — 960 MHz

Table 5-2 Output power

Frequency	Max output power	Min output power
GSM850	33dBm \pm 2dB	5dBm \pm 5dB
E-GSM900	33dBm \pm 2dB	5dBm \pm 5dB
DCS1800	30dBm \pm 2dB	0dBm \pm 5dB
PCS1900	30dBm \pm 2dB	0dBm \pm 5dB
GSM850(8-PSK)	27dBm \pm 3dB	5dBm \pm 5dB
E-GSM900(8-PSK)	27dBm \pm 3dB	5dBm \pm 5dB

DCS1800(8-PSK)	26dBm +3/-4dB	0dBm \pm 5dB
PCS1900(8-PSK)	26dBm +3/-4dB	0dBm \pm 5dB
UMTS2100	24dBm +1/-3dB	-56dBm \pm 5dB
UMTS1900	24dBm +1/-3dB	-56dBm \pm 5dB
UMTS850	24dBm +1/-3dB	-56dBm \pm 5dB
UMTS900	24dBm +1/-3dB	-56dBm \pm 5dB

Table 5-3 Receive sensitivity

Frequency	Receive sensitivity
GSM850	<-109dBm
E-GSM900	<-109dBm
DCS1800	<-109dBm
PCS1900	<-109dBm
UMTS2100	<-109dBm
UMTS1900	<-109dBm
UMTS850	<-109dBm
UMTS900	<-109dBm

5.2 Data link

L306 supports GPRS/EDGE CLASS12,and HSDPA/HSDPA R8. The actual application depends on the local network operator.

Table 5-4 Data Link

Version	Function	Max supported	Theoretical max peak rate
L306	GPRS	CS4	85.6kbps

L306	EDGE	MCS9	236.8kbps
L306E/A	HSDPA	Cat10	14.4Mbps
L306ME/MA	HSDPA	Cat14	21Mbps
L306HE/HA	HSDPA	Cat24	42Mbps
L306E/A	HSUPA	Cat6	5.76Mbps
L306ME/MA	HSUPA	Cat7	11Mbps
L306HE/HA	HSUPA	Cat7	11Mbps

5.3 Antenna Design

The access part of the RF antenna of this product supports the PAD form. The connection between the module and the main board antenna interface is required to be welded and connected through a microstrip line or a strip line. The microstrip line or strip line is designed according to the characteristic impedance of 50 ohm, and the length of the wire is less than 10mm. Reserved II matching network

Antenna efficiency

Antenna efficiency is the ratio of the input power and radiant power. Because of the return loss, material loss and coupling loss of the antenna, the radiant power is always lower than the input power. The ratio is recommended to be controlled over 40%(-4dB).

S11 or VSWR

S11 indicates the matching level of the 50 Ohm impedance for the antenna. It affects the antenna efficiency in a certain extent. The VSWR testing method could be used for measuring purpose. The recommended value for S11 is less than -10dB.

Polarization

Polarization refers to the rotation direction of electric field while the antenna is in the direction of maximum radiation. Linear polarization is recommended. It is recommended to use the diversity antenna which has the different polarization direction from the main antenna.

Radiation pattern

The radiation pattern refers to the intensity of the electromagnetic field while the antenna is in every direction of the far field. Dipole antenna is perfect as the terminal antenna. For built-in antenna, it is recommended to use PIFA or IFA antennas.

Antenna dimension: 6mm*10mm*100mm (H*W*L).

Antenna radiation direction: omnidirectional.

Gain and directivity

Antenna directivity refers to the intensity of the electromagnetic field while the electromagnetic wave is in all directions. Gain is the collection of the efficiency and directivity of the antenna. It is recommended that antenna gain is less than or equal to 3dBi.

Interference

In addition to antenna performance, some other interference from the PCB will also affect the module performance. To ensure the high performance of the module, the interference must be under control. Suggestions: keep speaker, LCD, CPU, FPC wire routing, audio circuits, and power supply away from the antenna, and add appropriate filtering and shielding protection, or adding filtering devices on the traces.

TRP/TIS

TRP(Total Radiated Power):

GSM850/900 >28dBm

GSM1800/1900 >25dBm

WCDMA Band1/8 >19dBm

TIS(Total Isotropic Sensitivity):

GSM850/900/1800/1900 <-102dBm

WCDMA Band1/8 <-102dBm

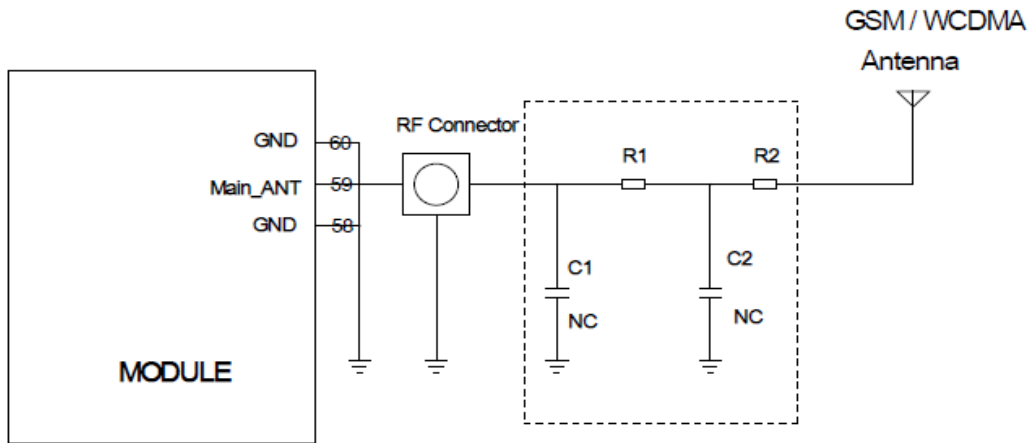

Figure 5-1 Main Antenna Design

Figure R1, C1, C2 and R2 composition of the antenna matching network for antenna debugging, the default R1, R2 paste 0 ohm resistor C2, C1 empty paste, to be antenna factory after the antenna to determine the value of the antenna.

Connector RF in the figure is used for testing and conducting test (for example, CE, FCC, etc.), which need to be placed as far as possible by the module, the RF path from the module to the antenna feed point should be kept 50 ohm impedance control.

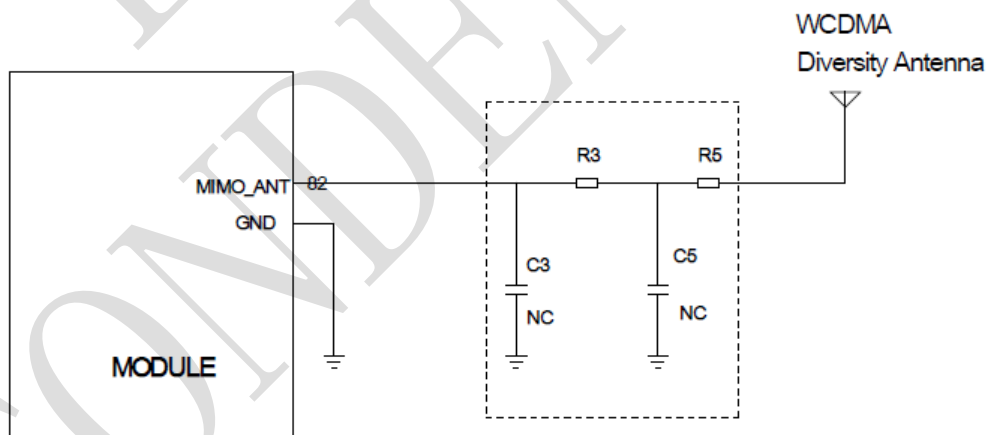

Figure 5-2 Div Antenna Design

Figure R3, C3, C5 and R5 composition of the antenna matching network for antenna debugging, the default R3, R5 paste 0 ohm resistor C5, C3 empty paste, to be antenna factory after the antenna to determine the value of the antenna.

6. Storage and Production

6.1 Storage

The rank of moisture proof of the module is level 3. There is an obvious sign on the table of the internal and the external packaging.

In the vacuum sealed bag, the module can be stored for 120 days when the temperature is 18~28°C and the humidity is 40~65%.

6.2 Production

The module is a humidity sensitive device. If the device needs reflow soldering, disassembly and maintenance, we must strictly comply with the requirements of humidity sensitive device. If module is damp, a reflow soldering or using a hot-air gun maintenance will lead to internal damage, because the water vapor has the rapid expansion of the burst, causing physical injury to the device, like PCB foaming and BGA component fail. So customers should refer to the following recommendations.

6.2.1 Module confirmation and moisture

The module in the production and packaging process should be strictly accordance with the humidity sensitive device operation. The factory packaging is vacuum bag, desiccant, and humidity indicator card. Please pay attention to the moisture control before SMT and the confirmation of the following aspects.

Product packaging confirmation

In order to ensure quality, smart module uses vacuum packaging and shipment, to avoid the question of SMT and function for the moisture in the air. Therefore, the requirements to confirm for the packaging of products before the SMT are necessary, ensuring the packaging not damaged, vacuum

packing not leaks. If there is any breakage and leakage, the Module should be baked, to avoid PCB foaming, BGA chip and RF PA chip fail.

Production cycle confirmation

The customer needs to confirm the production cycle of the product when receiving the product. If it exceed the storage period or the product has been affected with damp, the product must be baked. If the storage time not extended, and after opening the packaging, humidity indicator card is at 10% without discoloration, it indicate good packaging and can be normally used.

Humidity indicator card confirmation

If the module has according to the moisture level 3 processing, and internal packaging have been placed humidity indicator cards, customers should confirm the humidity indicator card before SMT. If the humidity indicator card has changed more than 10%, it need to carry on the material baking.

Baking condition confirmation

The moisture proof level of the smart module is level 3. And the baking conditions are as follows.

Table 6-1 Baking conditions

Baking conditions	90°/ 5%RH	60°/ 5%RH (Recommended)	40°/ 5%RH
Baking time	48 hours	72 hours	30days
Description	not use the original tray	not use the original tray	Can use the original tray

Customers can also choose baking conditions according to their own conditions. But please refer to Level 3 and device thickness 1.4 ~ 2.0mm standard.

Notes: The original anti-ESD tray temperature does not exceed 50 degree. Otherwise the tray will be deformed.

The anti-ESD tray of the original packaging is only used for packaging, and can't be used as a SMT tray.

Factory life confirmation

Module SMT with good humidity control should be completed in 48 hours after opening the package. The unused Module should be vacuum packaging, and placed in a drying box. If exposure to air for more than 48 hours, the module need to be baked. Due to the larger size of the module, damp needs to bake for a long time, and the price is high, so please try to run out after opening the package.

Customer product maintenance

If maintenance module after SMT, it is easy for damp module to damage when removing, so the module disassembly and other related maintenance operations should complete within 48 hours after SMT, or need to bake and then maintenance the module.

Because the module return from the field work can't ensure the dry state, it must be baked in accordance with the conditions of baking, then for disassembly and maintenance. If it has been exposed to the humid environment for a long time, please properly extend the baking time, such as 125 degrees /36 hours.

6.2.2 SMT reflow attentions

The module has the BGA chips, chip resistances and capacitances internally, which will melt at high temperature. If module melt completely encountered a large shock, such as excessive vibration of reflux conveyor belt or hit the board, internal components will easily shift or be false welding. So, using intelligent modules over the furnace need to pay attention to:

- Modules can't be vibrate larger, namely customer requirements as far as possible in orbit (chain) furnace, furnace, avoid on the barbed wire furnace, in order to ensure smooth furnace.
- The highest temperature can't too high. In the condition that meet the welding quality of customer motherboard and module, the lower furnace temperature and the shorter maximum temperature time, the better.

Some customer's temperature curve in the line is not suitable, high temperature is too high, and customer motherboard melt good, but non-performing rate is on the high side. Through the analysis of the causes, it found that melt again of BGA components lead device offset and short circuit. After adjusting the temperature curve, it can ensure that the customer's motherboard the welding quality, and also improve the pass through rate. Non-performing rate is controlled below the 2/10000.

6.2.3 SMT stencil design and the problem of less tin soldering

Part of customers found false welding or circuit short when reflowing. The main reason is module tin less, PCB distortion or tins too large. Suggestions are as follows:

- Suggest use ladder stencil 0.10-0.18mm, which means the region of module is proposed to 0.18mm stencil thickness. Please adjust validation according to the measured thickness of solder paste, the actual company conditions and experience value. The products need to strictly test.
- Stencil: Reference module package, and the user can adjust according to their company experience. Outside of the module, the stencil extends to 0.3mm outside. The GND pads use the net stencil.

In the production process, if you cannot judge the opening or process conditions, you can also contact our sales or after-sales service. We will give specific recommendations according to the actual situation.

6.2.4 SMT attentions

If customer motherboard is thin and slender with a furnace deformation, warping risks, you will be suggested to create "a furnace vehicle" to ensure the welding quality. Other production proposals are as follows:

- The solder pastes use brands like Alfa;
- The module must use the SMT machine mount (important), and do not recommend manually placed or manual welding.
- Please strictly control the pressure and speed in SMT (very important);
- We must use the reflow oven more than 8 temperature zones, and strictly control the furnace temperature curve.

Recommended temperature:

B. constant temperature zone: temperature 160-190°C, time: 60s-100s.

E. recirculation zone: PEAK temperature 235-245°C, time over 220°C: 30s-60s.

Notes: Customer's board deformation must be controlled within 0.15mm. By reducing the number of imposition or increasing patch clamp to reduce the deformation.

Module thickness of the stencil is recommended to be thickened to 0.18mm, and the rest position can be maintained by 0.1mm.