

REVISION RECORD				
REV	ECN	DESCRIPTION	DRFT	DATE

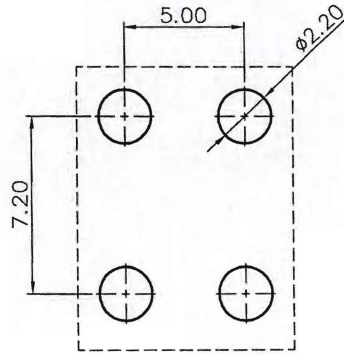

PCB LAYOUT

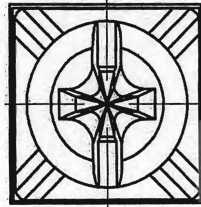
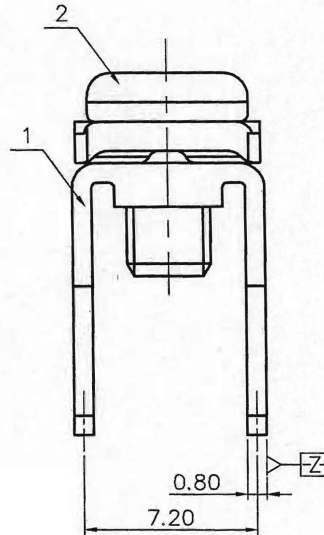
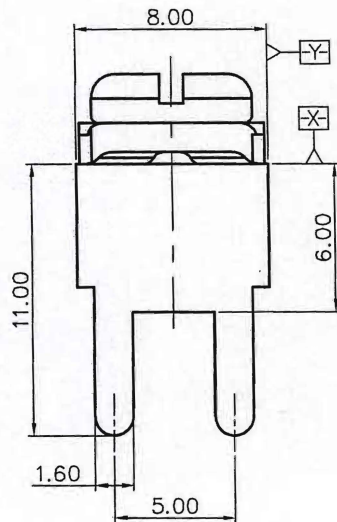

NOTES:

- Rated current : 15A
- Torque value : M3.5 , 7.02Lb.in
- Dimension shall be interpreted per ASME Y14.5-2009
- Undimensioned tolerances:

Pitch range in mm		Nominal dimension range in mm				0.1/10		
Over 6 TO 10	Over 10 TO 24	Over 30 TO 60	Over 60 TO 100	Over 100 TO 150				
± 0.15	± 0.20	± 0.30	± 0.30	± 0.50	± 0.70	± 1.00	± 1.30	$\pm 2'$

5.RoHS Compliance



ITEM	NAME OF PART	MATERIAL	NOTES
2	Screw	Steel	Ni Plated
1	Pin header	Copper alloy	Sn Plated

DETACHED LISTS	PART NO.: /		宁波高松电子有限公司 NINGBO DEGSON ELECTRICAL CO., LTD	
	APPD: Aaron Blum	NAME: K14-00A(H)		
	CHKD: [Signature]	TITLE: CUSTOMER DRAWING		
	DRFT: Yz 01/19/16"	DRAWING NO.: K14-C02	REV	TO
	THIRD ANGLE PROJECTION	DRAWING NO.: K14-C02	SHEET	1/1
	MM (INCH)	DO NOT SCALE DRAWING	SCALE	1:1