



Perfect Wireless Experience
完美无线体验

H330S-MINIPCIe-10

Hardware User Manual

Version : V1.1.1

Date : 2015.11.28



Copyright

Copyright ©2015 Fibocom Wireless Inc . All rights reserved.

Without the prior written permission of the copyright holder, any company or individual is prohibited to excerpt, copy any part of or the entire document, or transmit the document in any form.

Attention

The document is subject to update from time to time owing to the product version upgrade or other reasons. Unless otherwise specified, the document only serves as the user guide. All the statements, information and suggestions contained in the document do not constitute any explicit or implicit guarantee.

Trademark



The trademark is registered and owned by Fibocom Wireless Inc.

Versions

Version	Date	Remarks
V1.0.0	2012-09-07	Initial Version
V1.0.1	2012-12-24	Update product photo
V1.0.2	2013-01-09	Update the name of the document; add Reliability Features in specifications
V1.0.3	2013-05-02	Update the name of the document, upgrade the manual
V1.0.4	2013-05-27	Add Power Sequence description
V1.0.5	2013-09-11	Update the name of the document
V1.0.6	2014-08-14	Add the description of different version
V1.0.7	2015-04-26	Update the description of copyright and attention. Update the translation of the whole document.
V1.0.8	2015-05-08	1) Update the structure drawings, make the location hole mark be more

		clearer. 2) Update the SIM name in PIN definition.
V1.0.9	2015-07-27	Update the info of H330S and the logo.
V1.1.0	2015-10-09	Update the operating temperature.
V1.1.1	2015-11-28	Update the operating temperature.

Applicability Table

No.	Type	Note
1	H330S-A30-00-MiniPCIe-10	
2	H330S-A50-20-MiniPCIe-10	
3	H330S-Q50-20-MiniPCIe-10	

Content

1 Foreword.....	6
1.1 Introduction.....	6
1.2 Reference Standards.....	6
2 Product Overview.....	7
2.1 Description.....	7
2.2 Specifications.....	7
3 Interface Specifications.....	8
3.1 Mini PCIe interfaces.....	8
3.2 Antenna interface.....	10
4 Electrical Characteristics of Interfaces.....	11
4.1 Limiting Conditions.....	11
4.2 Environment Temperature.....	11
4.3 Timing Sequence Requirements of Power Supply Voltage.....	11
4.3.1 Power-on Time.....	11
4.3.2 Fall time.....	12
5 Interface Application.....	13
5.1 USB Interface.....	13
5.1.1 Description of USB Interface.....	13
5.1.2 Application of USB Interface.....	13
5.2 USIM Interface.....	14
5.2.1 Definition of USIM Card Signal Pins.....	14
5.2.2 Application Note of USIM Interface.....	14
5.3 Analog Audio Interface.....	15
5.3.1 Definition of Audio Interface Signals.....	15
5.3.2 Description of Audio Interface Application.....	15
5.3.3 Output Features of Audio Channel.....	15
5.4 UART Interface.....	16
5.4.1 Definition of UART Interface.....	16
5.4.2 Application of UART Interface.....	16

5.4.3 Ring Indication.....	17
5.5 Reset Signal.....	17
5.6 LPG Signal.....	18
5.7 W_DISABLE Signal.....	18
6 Product Structure.....	19
6.1 Overall Dimensions.....	19

1 Foreword

1.1 Introduction

The document describes the electrical characteristics, RF performance, dimensions and application environment, etc. of H330S-MiniPCle-10. With the assistance of the document and other instructions, developers can quickly understand the performance of H330S-MiniPCle-10 and develop products.

1.2 Reference Standards

The design of the product complies with the following standards:

《Mini PCI Express Card Electromechanical Specification Revision 1.0-2003》

2 Product Overview

2.1 Description

H330S-MiniPCle-10 is developed and designed based upon the H330S series module of FIBOCOM 3G wireless communication module and widely used in vehicle system, security system and other domains.

2.2 Specifications

Features	Description
Power Input	VCC: 3.0V ~ 3.6V (recommended value: 3.3V)
Physical	Dimension : 30mm x 50.95mm x 3.45mm
	Weight : <10g
Interface	Mini PCIe interface
Environment	Operating temperature: -30°C to +85°C
	Storage temperature: -40°C to +85°C
Antenna	Supports one antenna interface.
USB	USB2.0
UART	7-wire serial port (without DSR)
	2-wire serial port (only partial query functions are supported)
Reset signal	Supports the external reset signal
Audio	1 x Micphone in
Interfaces	1 x Handset out
Others	1 x W_DISABLE(get into fight mode control pin)
Interfaces	1 x LPG (network state index)

3 Interface Specifications

This chapter introduces the external interfaces and antenna interface of H330S Mini PCIe in detail

3.1 Mini PCIe interfaces

The pins definition of H330S-MiniPCIe-10 as listed below:

Pin #	Pin Name	I/O	Description
1	MICP	I	Audio channel—MIC signal input+
2	VCC	I	Power input
3	MICN	I	Audio channel—MIC signal input-
4	GND	G	GND
5	EARP	O	Audio channel—MIC signal input+
6	NC		—
7	EARN	O	Audio channel—MIC signal output-
8	USIM_VCC	O	USIM card power output 1.8v/3v
9	GND	G	GND
10	USIM_IO	I/O	USIM signal line
11	UART1_RX	I	UART1 data receiving
12	USIM_CLK	O	USIM RTC signal
13	UART1_TX	O	UART1 data sending
14	USIM_RST	O	USIM reset signal
15	GND	G	GND
16	NC		—
17	UART1_RI	O	UART1 ringing signal output
18	GND	G	GND
19	NC		—
20	W_DISABLE	I	Low level is effective, enter airplane mode.
21	GND	G	GND
22	RESET	I	Input of external reset signal
23	UART1_CTS	I	UART1 allows the input of data signal sending.

24	NC		—
25	UART1_RFR	O	UART1 reception ready
26	GND	G	GND
27	GND	G	GND
28	NC		—
29	GND	G	GND
30	NC		—
31	UART1_DTR	O	UART1 terminal ready
32	NC		—
33	UART1_DCD	O	UART1 carrier detect output
34	GND	G	GND
35	GND	G	GND
36	USB_D-	I/O	USB signal-
37	GND	G	GND
38	USB_D+	I/O	USB signal+
39	VCC	I	Power input
40	NC		—
41	VCC	I	Power input
42	LPG	O	Output of network state index signal
43	GND	G	GND
44	UART2_RX	I	UART2 data receiving
45	NC		—
46	UART2_TX	O	UART2 data sending
47	NC		—
48	NC		—
49	NC		—
50	GND	G	GND
51	NC		—
52	VCC	I	Power input

3.2 Antenna interface

H330S-MiniPCle-10 has an antenna interface which adopts the U.FL-R-SMT(01) connection interface of HIROSE and the specifications and PCB packaging are as follows:

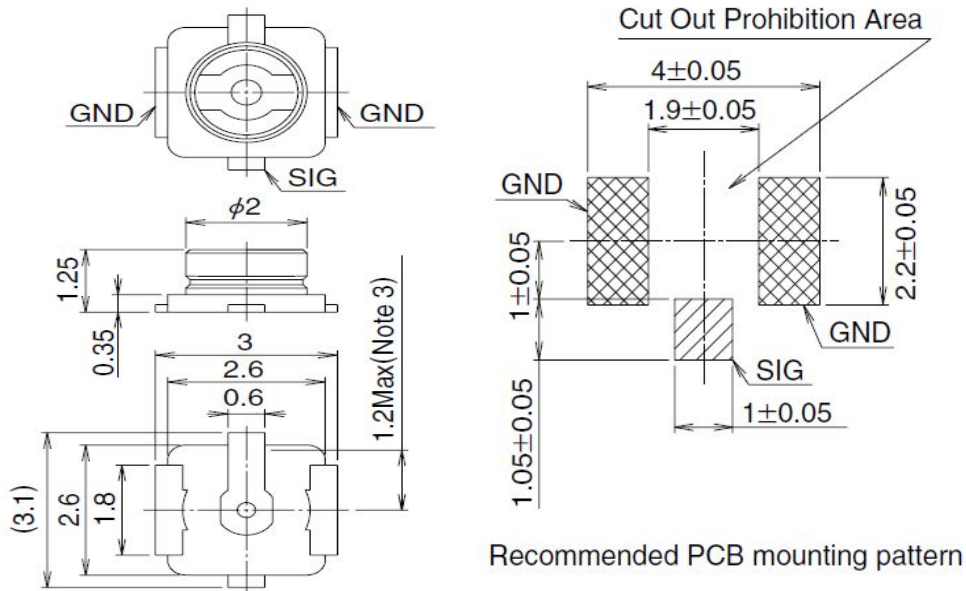

Figure 3-1 Dimension and PCB design

The performance of H330S-MiniPCle-10 as listed below:

Transmitting power (typical value)
Class 4 (2W) : 850/900 MHz, GSM
Class 1 (1W) : 1800/1900 MHz, GSM
Class E2 (0.5W) : 850/900 MHz, EDGE
Class E2 (0.4W) : 1800/1900 MHz, EDGE
Class 3 (0.25W) : 850/900/1900/2100 MHz, WCDMA
Receiving sensitivity (typical value)
UMTS/HSPA: -109dBm
GSM: -108dBm

4 Electrical Characteristics of Interfaces

This chapter introduces the electrical characteristics of H330S MiniPCle-10 mainly.

4.1 Limiting Conditions

Parameters	Description	Minimum Value	Maximum Value	Unit
VCC	Module input voltage	0	4.2	V
VIN	IO input voltage	0	3.6	V

4.2 Environment Temperature

Parameters	Minimum Value	Maximum Value	Unit
Operating temperature	-40	+85	°C
Storage temperature	-40	+85	°C

4.3 Timing Sequence Requirements of Power Supply Voltage

4.3.1 Power-on Time

For the power supply voltage for module, the requirement of setup time of voltage during start-up and power-on is as follows:

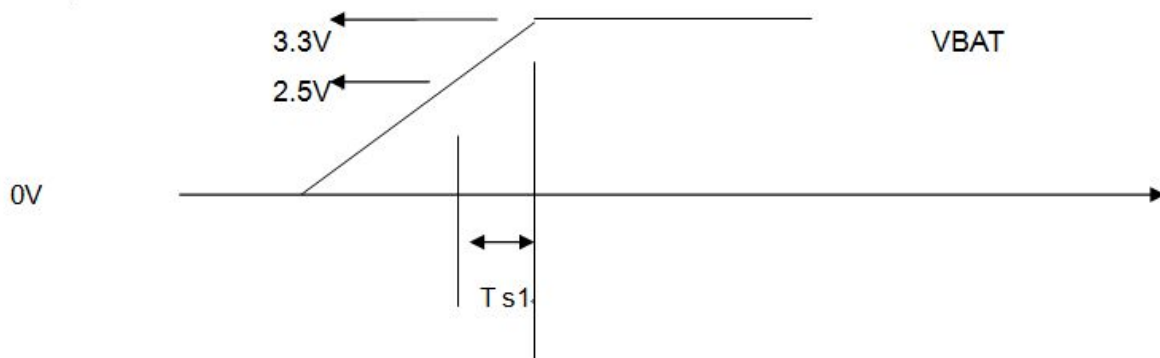

Figure 4- 1 Timing sequence of POWER_ON

	Description of time phase	Requirement
T s1	The interval when the power supply voltage increases to 3.3V from 2.5V.	Less than 5ms

Note: The normal start-up of module will be affected if the increase of power supply voltage takes too long during start-up.

4.3.2 Fall time

For the power supply voltage of module, the fall time of power supply in the corresponding module from voltage reduction to rise is as follows:

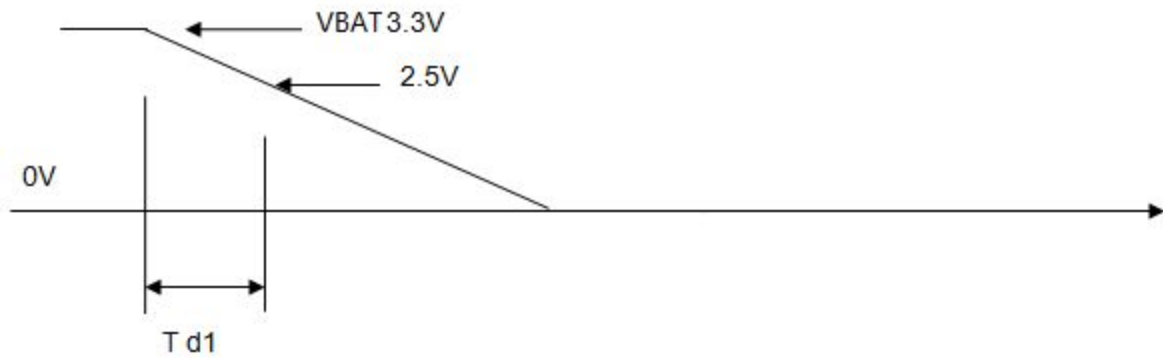

Figure 4- 1 Timing sequence of POWER_OFF

	Description of time phase	Requirement
T d1	The interval when the power supply voltage drop to 3.3V from 2.5V.	Less than 45ms

5 Interface Application

5.1 USB Interface

5.1.1 Description of USB Interface

H330S-MiniPCle-10 supports USB 2.0 and compatible with USB1.1. It requires installing the corresponding USB driver before using.

5.1.2 Application of USB Interface

Reference Circuit Design:

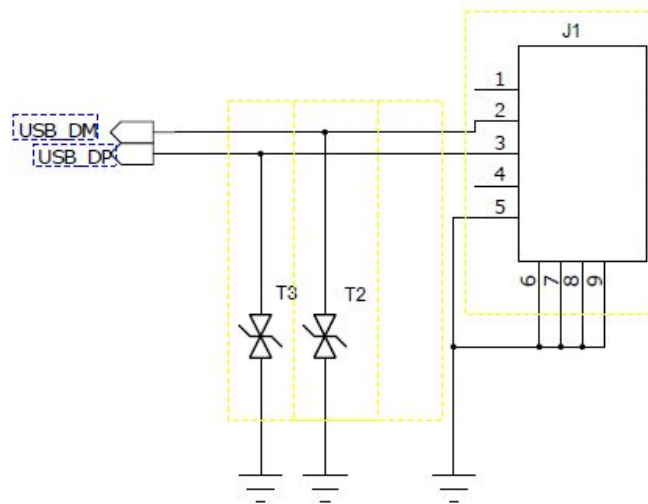

Figure 5- 1 Reference Circuit Design of USB Interface

T2 and T3 shall be TVS with capacitance lower than 1pF. USB_DP and USB_DM are the high-speed differential signal line, and their highest transmission rate is 480Mbps. The following requirements should be followed in designing PCB layout:

- USB_DP and USB_DM signal lines should have the same length, and should be parallel; avoid right angle wiring;
- USB_DP and USB_DM signal lines should be wrapped with GND at the ends.
- USB2.0 differential signal line should be laid at the signal layer closest to the ground layer.
- Ensure impedance matching; impedance is required to be 90ohm.

5.2 USIM Interface

5.2.1 Definition of USIM Card Signal Pins

Pin#	Pin Name	I/O	Function Description
8	USIM_VCC	O	USIM power supply signal
14	USIM_RST	O	USIM Reset signal
12	USIM_CLK	O	USIM RTC signal
10	USIM_IO	I/O	USIM data signal

5.2.2 Application Note of USIM Interface

Reference circuit design of USIM:

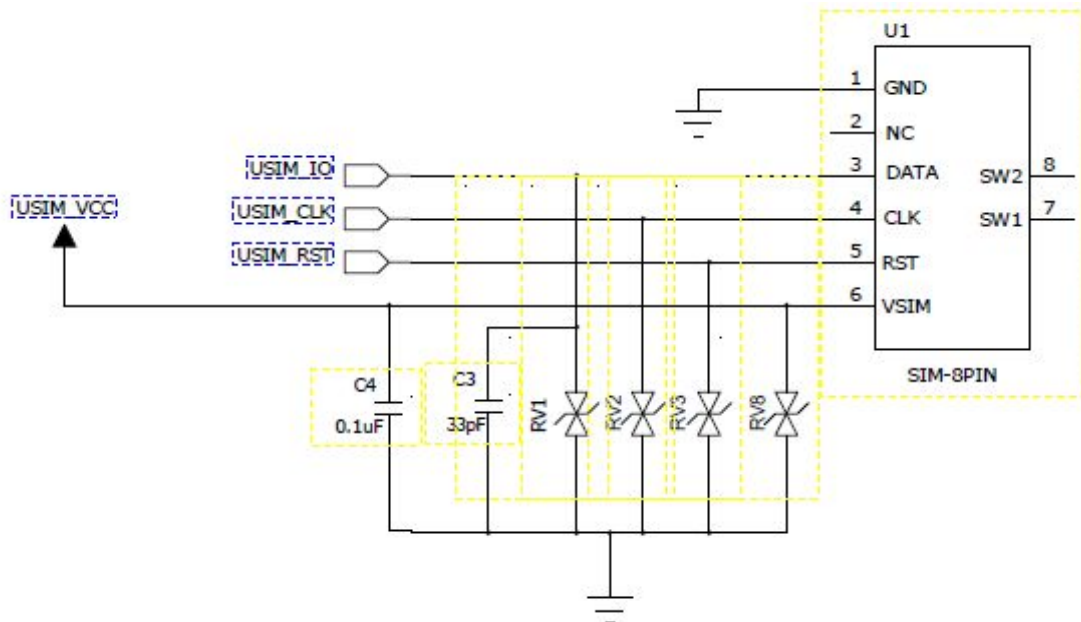

Figure 5-2 USIM Interface Reference Circuit

Note:

- In order to improve EMC performance, the SIM card slot should be close to the module.
- The filter capacitor on the SIM-card signal circuit should be placed close to SIM card pin to the largest extent.
- ESD device (like TVS) shall be added to the SIM-card signal circuit protection. ESD device should be placed close to SIM card pin.

5.3 Analog Audio Interface

5.3.1 Definition of Audio Interface Signals

H330S-MiniPCle-10 provides one audio signal input and one audio signal output.

The definition of audio signal as listed below:

Pin#	Pin Name	I/O	Description
7	EAR-	O	Audio channel earphone signal output -
5	EAR+	O	Audio channel earphone signal output+
1	MIC+	I	Audio channel 1MIC input signal +
3	MIC-	I	Audio channel 1MIC input signal -

5.3.2 Description of Audio Interface Application

Audio input/output signals are differential signals that have good performance in anti-RF-interference. When connecting to the phone handle, it is not necessary to add audio power amplifier.

As to PCB layout, the wires should have the same length, and should be parallel and as short as possible. The wires should be wrapped with ground wire. The input and output signals should be separated by grounding. It would be best to add ESD protection to the audio signal port.

5.3.3 Output Features of Audio Channel

Audio channel is a differential audio interface for calls through phone handle.

Chart 1: level features of MIC input interface

Parameters	Test conditions	Minimum Value	Typical Value	Maximum Value	Unit
Bias voltage	Without load		2.5	2.6	V
Gain	Programmable, stepping gain: 1dB	0		16	dB
Designed load impedance			2.2		Kohm

Chart 2: level features of EAR output interface:

Parameters	Test conditions	Minimum Value	Typical Value	Maximum Value	Unit
Output voltage	Without load			1.4	Vpp
Designed load impedance			32		ohm
DC Bias voltage			1		V

Note: The audio parameter of Audio channel 1 is handle's debugging parameters by default. If the users need use the earphone, then the corresponding audio parameters need debug.

5.4 UART Interface

5.4.1 Definition of UART Interface

H330S-MiniPCle-10 provides two UART for the users. One is the 7-line serial port; the other is the 2-line serial port.





The UART1 (7-line serial port) supports the flow control function and supports all AT commands, but don't support the UART1_DSR. The users can download the software or receive/send AT commands through the UART1. The UART2 (2-line serial port) only supports part of query function.

The definition of UART1 and UART2 signal interface as listed below:

UART1			
Pin#	Pin#	Pin#	Pin#
17	UART1_RI	O	UART1 Ring Indicator
31	UART1_DTR	O	UART1 DCE Ready
33	UART1_DCD	O	UART1 Carrier Detect
23	UART1_CTS	I	UART1 Clear to send
25	UART1_RFR	O	UART1 Receive for Ready
13	UART1_TXD	O	UART1 Data Sending
11	UART1_RXD	I	UART1 Data Receiving
UART2			
Pin#	Pin#	Pin#	Pin#
44	UART2_RXD	I	UART2 Data Receiving
46	UART2_TXD	O	UART2 Data Sending

5.4.2 Application of UART Interface

While the H330S-MiniPCle-10 (DCE) UART1 connect with PC (DTE), the signal direction as listed below:

MCU (DTE) application	Signal Direction	H330S MINI PCIE Module (DCE)
RXD		UART1_TXD
TXD		UART1_RXD
RTS		UART1_CTS
RFR		UART1_RFR
DTR		UART1_DTR

RI		UART1_RI
DCD		UART1_DCD

While H330S-MiniPCle-10 (DCE) UART2 connect to PC (DTE) ,the direction as follows:

MCU (DTE) application	Signal Direction	H330S MINI PCIE Module (DCE)
RXD		UART2_TXD
TXD		UART2_RXD

Note: The high level of UART interface of H330S-MiniPCle-10 wireless module is 3.3V.

5.4.3 Ring Indication

UART1_RI signal is used to indicate the incoming calls and SMS, and dispatch pulses to the host application.

Working modes	Status
Not ringing	Low level
Ringing	1s high level, and 1s low level, repeat this.
No new SMS	Low level
New SMS	150ms pulse

5.5 Reset Signal

H330S-MiniPCle-10 supports external reset function. It is feasible to reset the module back to the original state by the Reset Signal.

When setting the Reset Signal low for 100ms, the module will be reset and restarted. When the user uses the Reset function, the PMU inside the module will not lose power. Restart of PC-side virtual ports will be observed at this time if module is connected to PC ports.

Note: Reset signal is a sensitive signal line. In designing PCB layout, please keep the line away from RF interference, and make it well wrapped with ground wire. And it is advised to add an anti-shaking capacitor at the place close to the module end.

The timing sequence requirements of its pulse are as follows:

Parameter	Condition	Minimum Value	Typical Value	Maximum Value	Unit
Pulse Width		100	300	3000	ms

Recommended design:

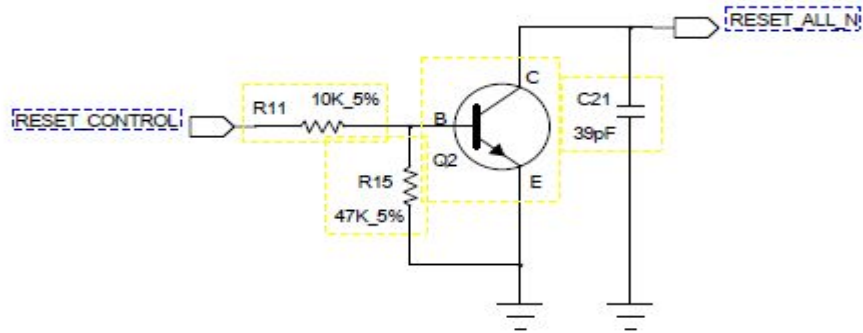

Figure 5-3 Reset Recommended Design

5.6 LPG Signal

LPG signal description as listed below:

Status	Mode
idle(unregistered)	600ms high level, 600ms low level
idle(registered)	75ms high level, 3S low level
Voice communication (Call)	low level
Data communicating	75ms high level, 75ms low level
Sleep (sleep mode)	high level

5.7 W_DISABLE Signal

Status	W_DISABLE Signal	Operating Mode
Normal mode	high level	W_DISABLE high level, module is in normal mode.
Flight mode	low level	Module will enter airplane mode when W_DISABLE is under low level.

