



# Product Technical Specification and User Guide

## AirLink GL8200



**SIERRA**  
WIRELESS®

4116298  
4.3  
March 11, 2016

## Important Notice

Due to the nature of wireless communications, transmission and reception of data can never be guaranteed. Data may be delayed, corrupted (i.e., have errors) or be totally lost. Although significant delays or losses of data are rare when wireless devices such as the Sierra Wireless modem are used in a normal manner with a well-constructed network, the Sierra Wireless modem should not be used in situations where failure to transmit or receive data could result in damage of any kind to the user or any other party, including but not limited to personal injury, death, or loss of property. Sierra Wireless accepts no responsibility for damages of any kind resulting from delays or errors in data transmitted or received using the Sierra Wireless modem, or for failure of the Sierra Wireless modem to transmit or receive such data.

## Safety and Hazards

Do not operate the Sierra Wireless modem in areas where cellular modems are not advised without proper device certifications. These areas include environments where cellular radio can interfere such as explosive atmospheres, medical equipment, or any other equipment which may be susceptible to any form of radio interference. The Sierra Wireless modem can transmit signals that could interfere with this equipment. Do not operate the Sierra Wireless modem in any aircraft, whether the aircraft is on the ground or in flight. In aircraft, the Sierra Wireless modem **MUST BE POWERED OFF**. When operating, the Sierra Wireless modem can transmit signals that could interfere with various onboard systems.

---

*Note: Some airlines may permit the use of cellular phones while the aircraft is on the ground and the door is open. Sierra Wireless modems may be used at this time.*

---

The driver or operator of any vehicle should not operate the Sierra Wireless modem while in control of a vehicle. Doing so will detract from the driver or operator's control and operation of that vehicle. In some states and provinces, operating such communications devices while in control of a vehicle is an offence.

## Limitations of Liability

This manual is provided "as is". Sierra Wireless makes no warranties of any kind, either expressed or implied, including any implied warranties of merchantability, fitness for a particular purpose, or noninfringement. The recipient of the manual shall endorse all risks arising from its use.

The information in this manual is subject to change without notice and does not represent a commitment on the part of Sierra Wireless. SIERRA WIRELESS AND ITS AFFILIATES SPECIFICALLY DISCLAIM LIABILITY FOR ANY AND ALL DIRECT, INDIRECT, SPECIAL, GENERAL, INCIDENTAL, CONSEQUENTIAL, PUNITIVE OR EXEMPLARY DAMAGES INCLUDING, BUT NOT LIMITED TO, LOSS OF PROFITS OR REVENUE OR ANTICIPATED PROFITS OR REVENUE ARISING OUT OF THE USE OR INABILITY TO USE ANY SIERRA WIRELESS PRODUCT, EVEN IF SIERRA WIRELESS AND/OR ITS AFFILIATES HAS BEEN ADVISED OF THE POSSIBILITY OF SUCH DAMAGES OR THEY ARE FORESEEABLE OR FOR CLAIMS BY ANY THIRD PARTY.

Notwithstanding the foregoing, in no event shall Sierra Wireless and/or its affiliates aggregate liability arising under or in connection with the Sierra Wireless product, regardless of the number of events, occurrences, or claims giving rise to liability, be in excess of the price paid by the purchaser for the Sierra Wireless product.

Customer understands that Sierra Wireless is not providing cellular or GPS (including A-GPS) services. These services are provided by a third party and should be purchased directly by the Customer.

**SPECIFIC DISCLAIMERS OF LIABILITY:** CUSTOMER RECOGNIZES AND ACKNOWLEDGES SIERRA WIRELESS IS NOT RESPONSIBLE FOR AND SHALL NOT BE HELD LIABLE FOR ANY DEFECT OR DEFICIENCY OF ANY KIND OF CELLULAR OR GPS (INCLUDING A-GPS) SERVICES.

## Patents

This product may contain technology developed by or for Sierra Wireless Inc.

This product includes technology licensed from QUALCOMM®.

This product is manufactured or sold by Sierra Wireless Inc. or its affiliates under one or more patents licensed from InterDigital Group and MMP Portfolio Licensing.

## Copyright

© 2016 Sierra Wireless. All rights reserved.

## Trademarks

Sierra Wireless®, AirPrime®, AirLink®, AirVantage®, WISMO®, ALEOS® and the Sierra Wireless and Open AT logos are registered trademarks of Sierra Wireless, Inc. or one of its subsidiaries.

Watcher® is a registered trademark of NETGEAR, Inc., used under license.

Windows® and Windows Vista® are registered trademarks of Microsoft Corporation.

Macintosh® and Mac OS X® are registered trademarks of Apple Inc., registered in the U.S. and other countries.

QUALCOMM® is a registered trademark of QUALCOMM Incorporated. Used under license.

Other trademarks are the property of their respective owners.

## Contact Information

Sales Desk:	Phone:	1-604-232-1488
	Hours:	8:00 AM to 5:00 PM Pacific Time
	Contact:	<a href="http://www.sierrawireless.com/sales">http://www.sierrawireless.com/sales</a>
Post:	Sierra Wireless 13811 Wireless Way Richmond, BC Canada V6V 3A4	
Technical Support:	<a href="mailto:support@sierrawireless.com">support@sierrawireless.com</a>	
RMA Support:	<a href="mailto:repairs@sierrawireless.com">repairs@sierrawireless.com</a>	
Fax:	1-604-231-1109	
Web:	<a href="http://www.sierrawireless.com/">http://www.sierrawireless.com/</a>	

Consult our website for up-to-date product descriptions, documentation, application notes, firmware upgrades, troubleshooting tips, and press releases: [www.sierrawireless.com](http://www.sierrawireless.com)

# Document History

Version	Date	Updates
1.0	September 03, 2014	Creation
2.0	March 17, 2015	Updated: <ul style="list-style-type: none"> <li>2.2.1.1 Power Supply</li> <li>Table 29 Handling Resistance Stress Tests</li> </ul>
2.1	April 01, 2015	Updated Figure 3 Mechanical Drawing
2.2	May 04, 2015	Updated section 8 Certification Compliance and Recommended Standards
	June 05, 2015	Updated: <ul style="list-style-type: none"> <li>4.1 Communications Testing</li> <li>6.2.2 Serial Port Shutdown Mode</li> <li>9 Cables and Accessories</li> <li>15 Appendix A: Packaging</li> <li>16 Appendix B: Product Labeling</li> </ul>
		Changed pin 5 of the Micro-Fit connector to "Reserved"
	June 17, 2015	Updated: <ul style="list-style-type: none"> <li>Baud rate to 115,200 bps</li> <li>2.2.1.2.3 2-wire Serial Interface Hardware Design</li> <li>Table 30 Standards Conformity for the GL8200</li> <li>Figure 11 Adaptive Cable for the GL8200</li> <li>Appendix B: Product Labeling</li> </ul>
3.0	September 07, 2015	Updated: <ul style="list-style-type: none"> <li>Table 8 Effects of Power Supply Overload/Underload</li> <li>11.1 Power Supply</li> </ul>
		Deleted 11.2 Overvoltage
4.0	February 22, 2016	Updated 9.1.1 8-pin Micro-Fit Edge
4.1	March 07, 2016	Updated: <ul style="list-style-type: none"> <li>2.2.1 8-pin Micro-Fit Connector</li> <li>Table 31 8-pin Micro-Fit Pin Description of the Adaptive Cable</li> </ul>
4.2	March 09, 2016	Updated Micro-Fit connector pin numbers throughout the document
4.3	March 11, 2016	Updated: <ul style="list-style-type: none"> <li>Table 6 Micro-Fit Connector Pin Description</li> <li>Table 7 Input Power Supply Voltage</li> <li>Table 9 Serial Link Pin Description from the Micro-Fit Connector (CN201)</li> <li>Figure 8 4-wire Serial Link Implementation</li> <li>2.2.1.2.3 2-wire Serial Interface Hardware Design</li> </ul>



# Contents

<b>1. OVERVIEW .....</b>	<b>10</b>
1.1. General Information.....	10
1.1.1. Physical Dimensions .....	10
1.1.2. RF Features .....	11
1.1.3. Interfaces.....	11
1.1.4. Connection Interfaces .....	11
1.1.5. Environmental Compliance .....	11
1.1.5.1. RoHS Compliance .....	11
1.1.5.2. Disposing of the Product .....	11
1.2. Functional Architecture.....	12
1.2.1. RF Functionalities .....	12
1.2.2. Operating System .....	12
1.3. Mechanical Specifications .....	13
1.3.1. Mechanical Drawings .....	13
1.3.2. Product Color .....	14
<b>2. INTERFACES/PERIPHERALS.....</b>	<b>15</b>
2.1. Front Interface .....	15
2.1.1. SIM Interface.....	15
2.1.2. Flash LED.....	16
2.2. Back Interface.....	17
2.2.1. 8-pin Micro-Fit Connector.....	17
2.2.1.1. Power Supply .....	18
2.2.1.2. Serial Link (RS232) .....	18
2.2.2. RF Interface .....	21
2.2.2.1. RF Connections.....	21
2.2.2.2. RF Performances .....	21
2.2.2.3. Antenna Specifications .....	21
<b>3. USING THE GL8200 .....</b>	<b>23</b>
3.1. Getting Started .....	23
3.1.1. Inserting the SIM Card .....	24
3.1.2. Extracting the SIM Card .....	25
3.2. Operational Status.....	25
<b>4. COMMUNICATING WITH THE GL8200 .....</b>	<b>26</b>
4.1. Communications Testing .....	26
4.1.1. Default Serial Interface.....	26
4.1.2. Flow Control Option .....	26
4.2. Checking the PIN Code Status.....	27
4.3. Verify the Received Signal Strength.....	27
4.4. Verify the Network Registration .....	28
4.5. Main AT Commands for the GL8200.....	28

4.6.	Echo Function.....	29
<b>5.</b>	<b>TROUBLESHOOTING THE GL8200 .....</b>	<b>30</b>
5.1.	No Communications with the GL8200 through the Serial Link.....	30
5.2.	Receiving an “ERROR” Message.....	31
5.3.	Receiving a “NO CARRIER” Message .....	31
5.4.	Resetting the GL8200.....	32
<b>6.</b>	<b>POWER CONSUMPTION .....</b>	<b>33</b>
6.1.	Consumption Measurement Procedure.....	33
6.1.1.	Hardware Configuration .....	33
6.1.1.1.	Equipment .....	33
6.1.1.2.	SIM Cards.....	34
6.1.2.	Software Configuration.....	34
6.1.2.1.	Modem Configuration .....	34
6.1.2.2.	Equipment Configuration .....	34
6.2.	Operating Modes .....	35
6.2.1.	Entering Sleep Mode.....	35
6.2.2.	Serial Port Shutdown Mode .....	36
6.3.	Power Consumption Values .....	36
<b>7.</b>	<b>RELIABILITY COMPLIANCE AND RECOMMENDATIONS.....</b>	<b>38</b>
7.1.	Environmental Specifications .....	38
7.1.1.	Function Status Classification .....	38
7.2.	Reliability Prediction Model .....	39
7.2.1.	Life Stress Test .....	39
7.2.2.	Environmental Resistance Stress Tests .....	39
7.2.3.	Corrosive Resistance Stress Test.....	40
7.2.4.	Thermal Resistance Cycle Stress Test.....	40
7.2.5.	Mechanical Resistance Stress Tests .....	41
7.2.6.	Handling Resistance Stress Tests .....	42
<b>8.</b>	<b>CERTIFICATION COMPLIANCE AND RECOMMENDED STANDARDS .....</b>	<b>43</b>
<b>9.</b>	<b>CABLES AND ACCESSORIES .....</b>	<b>44</b>
9.1.	Adaptive Cable .....	44
9.1.1.	8-pin Micro-Fit Edge .....	44
9.1.2.	DB9 Edge .....	45
9.1.3.	2-pin Micro-Fit Edge .....	46
9.2.	DC Cable .....	46
9.3.	Antenna .....	47
<b>10.</b>	<b>MECHANICAL CONSTRAINTS.....</b>	<b>48</b>
10.1.	Micro-Fit Connector .....	48
10.2.	FME RF Connector.....	48

<b>11. PROTECTIONS</b> .....	<b>49</b>
11.1. Power Supply .....	49
11.2. Electrostatic Discharge .....	49
11.3. Miscellaneous .....	49
<b>12. UPGRADE GUIDELINES</b> .....	<b>50</b>
12.1. Operating System Upgrade .....	50
12.2. Firmware Upgrade .....	50
<b>13. REFERENCES</b> .....	<b>51</b>
13.1. Sierra Wireless Reference Documentation .....	51
13.2. General Reference Documentation .....	51
13.3. List of Abbreviations .....	51
<b>14. SAFETY RECOMMENDATIONS (FOR INFORMATION ONLY)</b> .....	<b>54</b>
14.1. RF Safety .....	54
14.1.1. General .....	54
14.1.2. Exposure to RF Energy .....	54
14.1.3. Efficient Terminal Operation .....	54
14.1.4. Antenna Care and Replacement .....	55
14.2. General Safety .....	55
14.2.1. Driving .....	55
14.2.2. Electronic Devices .....	55
14.2.3. Vehicle Electronic Equipment .....	55
14.2.4. Medical Electronic Equipment .....	55
14.2.5. Aircraft .....	56
14.2.6. Children .....	56
14.2.7. Blasting Areas .....	56
14.2.8. Potentially Explosive Atmospheres .....	56
<b>15. APPENDIX A: PACKAGING</b> .....	<b>57</b>
<b>16. APPENDIX B: PRODUCT LABELING</b> .....	<b>58</b>
16.1. Model and MSN Label .....	58
16.2. IMEI and Approval Label .....	58



## List of Figures

Figure 1.	AirLink GL8200 Modem.....	10
Figure 2.	Functional Architecture.....	12
Figure 3.	Mechanical Drawing .....	13
Figure 4.	GL8200 Front View .....	15
Figure 5.	GL8200 Back View.....	17
Figure 6.	Pin Assignment of the 8-pin Micro-Fit Connector.....	17
Figure 7.	5-wire RS232 Serial Link Signals .....	19
Figure 8.	4-wire Serial Link Implementation .....	20
Figure 9.	2-wire Serial Link Implementation .....	20
Figure 10.	Typical Hardware Configuration .....	33
Figure 11.	Adaptive Cable for the GL8200 .....	44
Figure 12.	8-pin Micro-Fit Edge of the Adaptive Cable .....	44
Figure 13.	DB9 Edge of the Adaptation Cable .....	45
Figure 14.	2-pin Micro-Fit Edge of the Adaptive Cable .....	46
Figure 15.	Pin Assignment of the 2-pin Micro-Fit Edge.....	46
Figure 16.	DC Cable .....	46
Figure 17.	Pin Assignment of the DC Cable.....	46
Figure 18.	Two Pizza Boxes in an Outer Box.....	57
Figure 19.	GL8200 in a Pizza Box.....	57
Figure 20.	Model and MSN Label.....	58
Figure 21.	IMEI and Approval Label .....	58



# List of Tables

Table 1.	Box Casing Properties.....	10
Table 2.	Supported Bands/Connectivity.....	12
Table 3.	Available Interface Signals.....	15
Table 4.	SIM Interface Electrical Characteristics.....	16
Table 5.	LED Status.....	16
Table 6.	Micro-Fit Connector Pin Description.....	17
Table 7.	Input Power Supply Voltage.....	18
Table 8.	Effects of Power Supply Overload/Underload.....	18
Table 9.	Serial Link Pin Description from the Micro-Fit Connector (CN201).....	19
Table 10.	FME Antenna Connector of GL8200.....	21
Table 11.	Antenna Specifications.....	21
Table 12.	AT+CPIN Responses.....	27
Table 13.	Received Signal Strength Values.....	27
Table 14.	Network Registration Values.....	28
Table 15.	Main AT Commands for the GL8200.....	28
Table 16.	Solutions for No Connection with the GL8200 through the (2-wire) Serial Link.....	30
Table 17.	Solutions for Receiving a “NO CARRIER” Message.....	31
Table 18.	Extended Error Codes.....	32
Table 19.	List of Recommended Equipment.....	34
Table 20.	Operating Modes.....	35
Table 21.	Power Consumption (Typical Values).....	36
Table 22.	Operating Class Temperature Range.....	38
Table 23.	ISO Failure Mode Severity Classification.....	38
Table 24.	Life Stress Test.....	39
Table 25.	Environmental Resistance Stress Tests.....	39
Table 26.	Corrosive Resistance Stress Test.....	40
Table 27.	Thermal Resistance Cycle Stress Test.....	40
Table 28.	Mechanical Resistance Stress Tests.....	41
Table 29.	Handling Resistance Stress Tests.....	42
Table 30.	Standards Conformity for the GL8200.....	43
Table 31.	8-pin Micro-Fit Pin Description of the Adaptive Cable.....	44
Table 32.	DB9 Connector Pin Description.....	45
Table 33.	2-pin Micro-Fit Connector Pin Description.....	46
Table 34.	DC Cable Pin Description.....	47
Table 35.	Recommended Antenna Description.....	47
Table 36.	Micro-Fit Connector Mechanical Constraints.....	48
Table 37.	FME RF Connector Mechanical Constraints.....	48

# >> 1. Overview

The AirLink GL8200 is a wireless modem that allows users to connect to a wireless network by plugging in a Micro-Fit cable and an RF antenna. It offers data connectivity on GPRS, EDGE, WCDMA, HSDPA and HSUPA networks; and was designed by using the AirPrime HL8548 embedded module.

The following section provides information about the physical attributes and briefly summarizes the modem's features, interfaces and connectors.

## 1.1. General Information

### 1.1.1. Physical Dimensions



Figure 1. AirLink GL8200 Modem

The modem has a complete box casing with the following properties.

Table 1. Box Casing Properties

Dimension	Value
Length	67mm
Width	51.5mm
Thickness	23.7mm
Weight	60.5g

## 1.1.2. RF Features

- GSM/GPRS/EDGE
  - 2 Watts GSM850 and EGSM 900 radio section
  - 1 Watt DCS and PCS radio section
  - Hardware GPRS/EDGE class 33 capable
- WCDMA
  - Penta-band UMTS WCDMA FDD (850 MHz(B5/B6), 900MHz(B8), 1900 MHz(B2), 2100MHz(B1))
  - 23 dBm (+/- 2dBm) Class 3bis

## 1.1.3. Interfaces

- 3V/1V8 SIM interface
- RF interface
- 5-wire Serial link (RS232) interface
- Power supply DC input from 4.75V to 32V
- Flash LED indicator

## 1.1.4. Connection Interfaces

- One SIM connector
- One FME (PLUG) type RF connector
- One 8-pin Micro-Fit connector for serial link (RS232) and power supply

## 1.1.5. Environmental Compliance

### 1.1.5.1. RoHS Compliance

The modem is compliant with RoHS Directive 2011/65/EU which sets limits for the use of certain restricted hazardous substances. This directive states that “from 1st July 2006, new electrical and electronic equipment put on the market does not contain lead, mercury, cadmium, hexavalent chromium, polybrominated biphenyls (PBB) or polybrominated diphenyl ethers (PBDE)”.

### 1.1.5.2. Disposing of the Product

This electronic product is subject to the EU Directive 2012/19/EU for Waste Electrical and Electronic Equipment (WEEE). As such, this product must not be disposed of at a municipal waste collection point. Please refer to local regulations for directions on how to dispose of this product in an environmental friendly manner.



## 1.2. Functional Architecture

The global architecture is shown in the figure below.

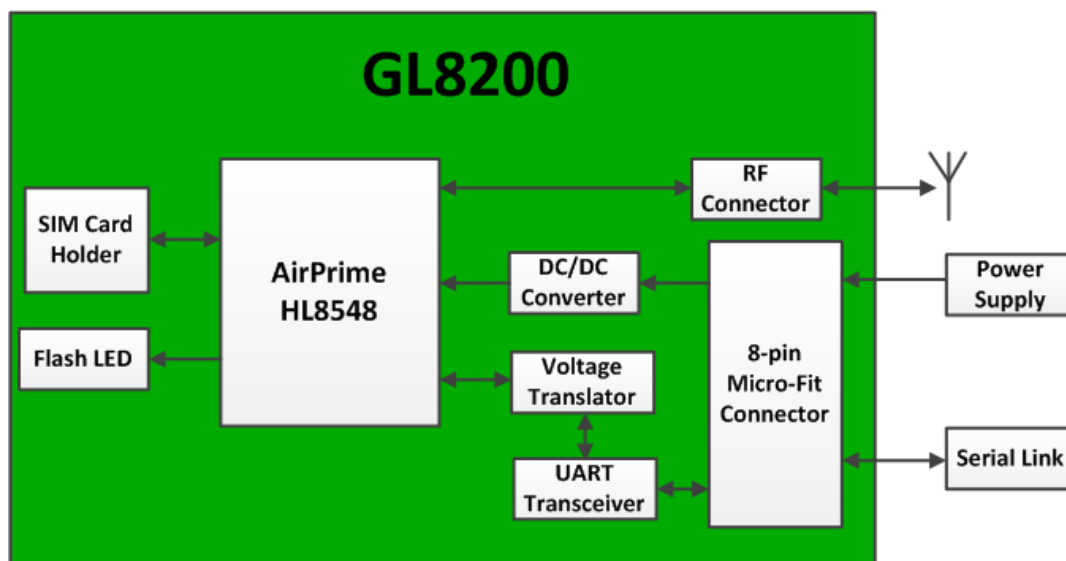

Figure 2. Functional Architecture

### 1.2.1. RF Functionalities

The Radio Frequency (RF) range complies with the 3GPP requirements. The corresponding frequency recommendations for both transmission and reception bands are listed in the table below.

Table 2. Supported Bands/Connectivity

RF Band	Transmit band (Tx)	Receive band (Rx)	Maximum Output Power
UMTS B1	1922 to 1978 MHz	2112 to 2168 MHz	23 dBm (+/- 2dBm) Class 3bis
UMTS B2	1852 to 1908 MHz	1932 to 1988 MHz	23 dBm (+/- 2dBm) Class 3bis
UMTS B5	826 to 847 MHz	871 to 892 MHz	23 dBm (+/- 2dBm) Class 3bis
UMTS B6	832 to 838 MHz	877 to 883 MHz	23 dBm (+/- 2dBm) Class 3bis
UMTS B8	882 to 913 MHz	927 to 958 MHz	23 dBm (+/- 2dBm) Class 3bis
GSM 850	824 to 849 MHz	869 to 894 MHz	2 Watts GSM, GPRS and EDGE
E-GSM 900	880 to 915 MHz	925 to 960 MHz	2 Watts GSM, GPRS and EDGE
DCS 1800	1710 to 1785 MHz	1805 to 1880 MHz	1 Watt GSM, GPRS and EDGE
PCS 1900	1850 to 1910 MHz	1930 to 1990 MHz	1 Watt GSM, GPRS and EDGE

### 1.2.2. Operating System

The operating system of the modem is responsible for the following functions:

- Drives the modem via an AT Command interface over a serial port
- Real Time Clock (RTC) with calendar
- Dual-mode UMTS (WCDMA) / HSDPA / HSUPA / EDGE / GPRS / GSM operation

---

*Note: The GL8200 is not programmable.*



## 1.3.2. Product Color

The GL8200 comes in:

OSAKI BLACK



Muncell 10B 1.5/0.5

DIC 581B

(PANTONE 426C)

C5%M5%Y0or5%K90%

R24G25B26

HTML: #18191A

## 2. Interfaces/Peripherals

This section describes the different connectors, interfaces and peripherals that connect with the modem.

The modem is distributed in the market as a finished product with the following interfaces:

- an 8-pin Micro-Fit Connector
- an FME RF Connector
- a Flash LED Indicator
- a SIM Connector

The interface signals available from the modem are listed in the following table. For more information about these signals, refer to the corresponding chapters.

Table 3. Available Interface Signals

Name	Driven by AT Commands
Serial Link (RS232)	Yes
SIM Interface	Yes
LED Signal	Yes

### 2.1. Front Interface



Figure 4. GL8200 Front View

#### 2.1.1. SIM Interface

The Subscriber Identification Module can be directly inserted in the modem through the SIM door.

The SIM interface controls both 1.8V and 3V SIM cards and it is fully compliant with GSM 11.11 recommendations concerning SIM functions.

The SIM interface is ESD protected. Transient Voltage Suppressor diodes are internally added on the signals connected to the SIM interface in order to prevent any damage from electrostatic discharge.

The SIM uses five SIM signals, namely:

- SIM-VCC, which is the SIM power supply
- SIM-RST, which is reset
- SIM-CLK, is clock
- SIM-IO, as the I/O port
- SIM-DET, for SIM detection

Refer to the following table for the electrical characteristics of the SIM interface.

**Table 4. SIM Interface Electrical Characteristics**

Parameter	Min.	Typ.	Max.	Remarks
SIM Interface Voltage (V) (VCC,CLK,IO,RST)	2.7	3.0	3.15	The appropriate output voltage is auto-detected and selected by software.
	1.65	1.80	1.95	
SIM-DET	1.33	1.80	2.10	High active
SIM-VCC Current (mA)	-	-	10	In sleep mode Max output current = 3mA
SIM-VCC Line Regulation (mV/V)	-	-	50	At Iout_Max
SIM-VCC Power-up Setting Time from power down (us)	-	10	-	

## 2.1.2. Flash LED

The GL8200 has an LED indicator to show the status of the GSM network.

**Table 5. LED Status**

Modem State	LED Status	Modem Status
ON	Permanently lighted	The modem is powered ON, but not registered in the network.
	Slow flash (LED is switched ON for 200ms, OFF for 2s)	The modem is powered ON, and registered in the network.
	Quick flash (LED is switched ON for 200ms, OFF for 600ms)	The modem powered ON, registered on the network, and communication is in progress.
OFF	OFF	The modem is either switched OFF or the FLASH-LED has been disabled by the user.

The Flash LED can be

- deactivated by the AT command **AT+KSYNC=0**
- activated by the AT command **AT+KSYNC=2, 4**

For more information about AT commands applicable to the GL8200, please refer to the commands marked as supported by HL8548x in document [2] AirPrime HL6 and HL8 Series AT Commands Interface Guide.

## 2.2. Back Interface

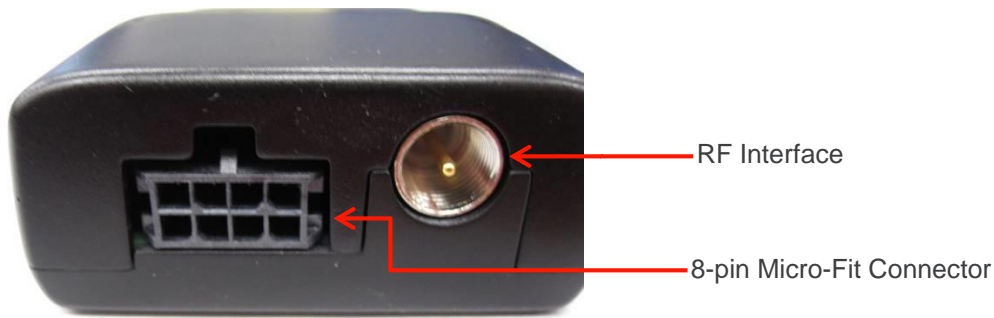

Figure 5. GL8200 Back View

### 2.2.1. 8-pin Micro-Fit Connector

The 8-pin Micro-Fit connector is used for the following connections:

- External DC power supply connection with voltage from 4.75V to 32V
- Serial link (RS232) interface

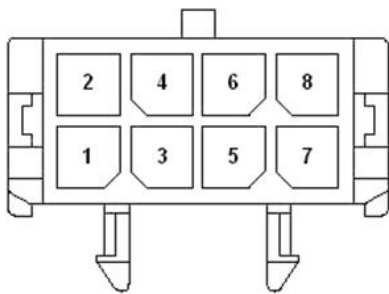

Figure 6. Pin Assignment of the 8-pin Micro-Fit Connector

Table 6. Micro-Fit Connector Pin Description

Pin #	Signal	I/O	I/O Type	Voltage	Description
1	RS232-CTS	O	RS-232	5.5V	Clear To Send
2	RS232-RTS	I	RS-232	5.5V	Request To Send
3	RS232-RXD	O	RS-232	5.5V	Receive Serial Data
4	RS232-TXD	I	RS-232	5.5V	Transmit Serial Data
5	RS232-DTR	I	RS-232	5.5V	Data Terminal Ready
6	GND	-	GND	GND	Ground
7	VIN-VBUS	I	Power Supply	4.75V – 32V	4.75V to 32V DC input
8	-	-	-	-	Reserved

**Note:** Pins 1 – 5 are used by the serial link interface. It is strictly prohibited to connect them to any power supply at the risk of damaging the GL8200.

### 2.2.1.1. Power Supply

The GL8200 is supplied by an external DC voltage (VIN-VBUS) that ranges from 4.75V to 32V at 2.2A. This input is available on the modem from the 8-pin Micro-Fit connector.

Table 7. Input Power Supply Voltage

Pin Number	Signal	Description
6	GND	Ground connection
7	VIN-VBUS	4.75V to 32V DC input

Note that the correct operation of the GL8200 in communication mode is not guaranteed if input voltage (VIN-VBUS) falls below 4.75V.

The following table describes the consequences of having the GL8200 go either over or under the specified voltage range.

Table 8. Effects of Power Supply Overload/Underload

If the voltage	Then
Falls below 4.75V	Wireless communication is not guaranteed.
Is over 32V (transient peaks)	External protection should be implemented on the GL8200.
Is over 32V (continuous over voltage)	External protection should be implemented on the GL8200.

*Note: The minimum input voltage specified here is the GL8200 input. Be mindful of the input voltage decrease caused by the power cable. When using the cable that comes with the GL8200, this input drop is at around 800mV at 4.75V and 220mV at 32V.*

*The power supply must withstand a current peak of 2.8A in 4.75V input voltage. Refer to Table 21 Power Consumption (Typical Values) for more current information.*

### 2.2.1.2. Serial Link (RS232)

The modem's serial link, RS232, performs the voltage level adaptation (V24/CMOS) between the GL8200 (DCE) and external applications (DTE).

The RS232 interface is internally protected against electrostatic surges on its lines by ESD protection.

The RS232 interface has the following filtering guarantees:

- EMI/RFI protection on both the input and the output
- Signal smoothing

Signals available on the RS232 serial link are as follows:

- TX data (RS232-TXD)
- RX data (RS232-RXD)
- Request To Send (RS232-RTS)
- Clear To Send (RS232-CTS)
- Data Terminal Ready (RS232-DTR)

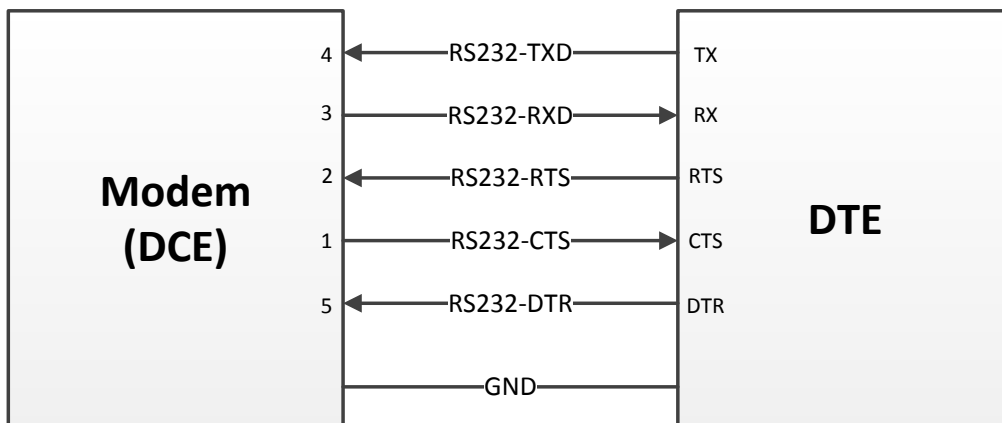

Figure 7. 5-wire RS232 Serial Link Signals

### 2.2.1.2.1. Pin Description

Table 9. Serial Link Pin Description from the Micro-Fit Connector (CN201)

Pin #	Signal*	I/O**	I/O Type	Reset State	Description
1	RS232-CTS	O	RS-232	Z	Clear To Send
2	RS232-RTS	I	RS-232	Z	Request To Send
3	RS232-RXD	O	RS-232	1	Receive Serial Data
4	RS232-TXD	I	RS-232	Z	Transmit Serial Data
5	RS232-DTR	I	RS-232	Z	Data Terminal Ready
6	GND	-	GND		Ground

\* According to PC (DTE) view.

\*\* According to modem (DCE) view, from which the direction of the signal is defined.

The RS232 interface has been designed to allow flexibility in the use of the serial interface signals. However, the use of TX and RX signals are mandatory; while the use of CTS, RTS and DTR signals are optional.

*Note: The modem is designed to operate with Hardware Flow Control. It is recommended to use RS232-RTS and RS232-CTS for hardware flow control in order to avoid data corruption during transmission.*

*The modem also implements the Serial Port Shutdown feature with the DTR signal. It is recommended to use RS232-DTR signal to benefit from the current consumption improvement performed by this feature. For more information about the Serial Port Shutdown, refer to section 6.2.2 Serial Port Shutdown Mode.*

### 2.2.1.2.2. 4-wire Serial Interface Hardware Design

The signals used in this interface hardware design are as follows:

- RS232-TXD
- RS232-RXD
- RS232-CTS
- RS232-RTS

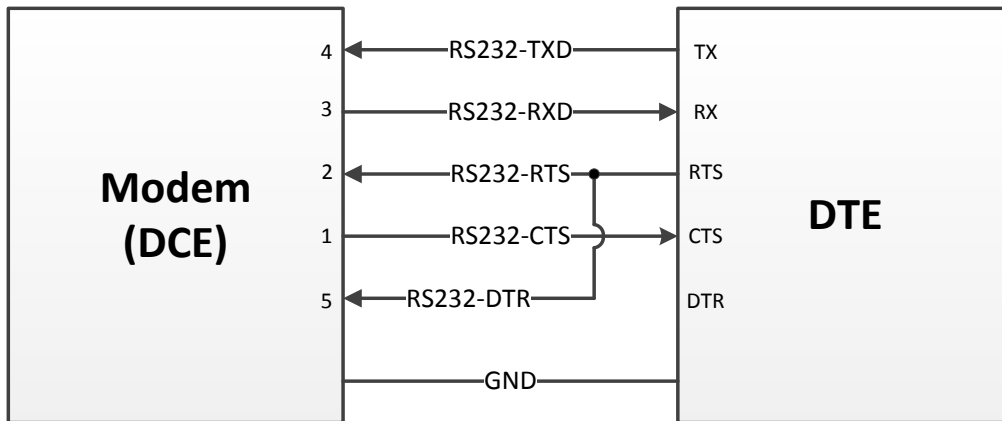

Figure 8. 4-wire Serial Link Implementation

**Note:** The RS232-DTR signal must be managed following the V24 protocol signaling if the Sleep Mode and Serial Port Shutdown features are to be used.

### 2.2.1.2.3. 2-wire Serial Interface Hardware Design

This is the default serial interface configuration when the module is shipped. The signals used in this interface hardware design are as follows:

- RS232-TXD
- RS232-RXD

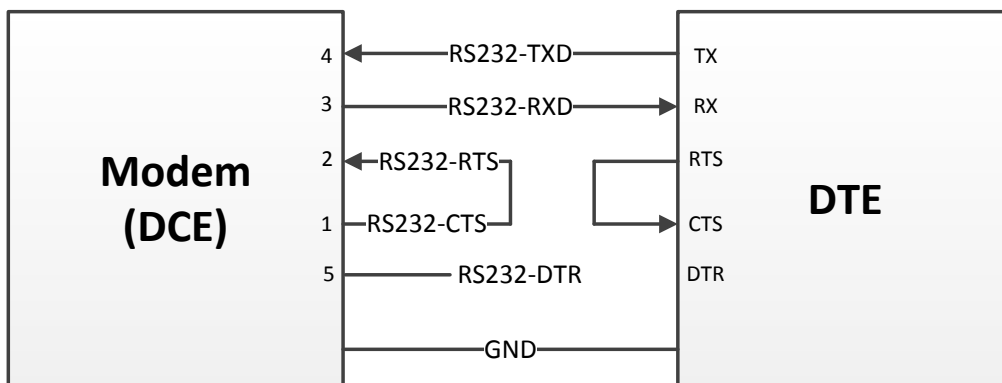

Figure 9. 2-wire Serial Link Implementation

**Note:** When reverting to a 2-wire serial interface implementation from either a 5-wire or 4-wire implementation, the modem must be configured using AT commands `AT+KGPIO=7,0` and `AT+KSLEEP=2` before the 2-wire serial interface is re-implemented.

The RS232-DTR signal must be managed following the V24 protocol signaling if the Sleep Mode and Serial Port Shutdown features are to be used.

The RS232-CTS and RS232-RTS signals are not used in this configuration. If needed, AT commands `AT&K3` and `AT&W0` can be used to enable the flow control function on the embedded module.

For more information about AT commands applicable to the GL8200, please refer to the commands marked as supported by HL8548 in document [2] AirPrime HL6 and HL8 Series AT Commands Interface Guide.

## 2.2.2. RF Interface

The antenna connector allows the transmission of radio frequency (RF) signals from the device to an external customer supplied antenna. The connector is an FME Coaxial Connector (male).

The nominal impedance of the antenna interface is 50Ω.

Table 10. FME Antenna Connector of GL8200

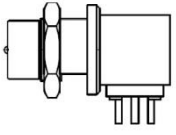
Supplier	Description	Vendor Part Number	
Amphenol CNT	FME Coaxial Connector, PCB Mounted, 50Ω, DC-3GHz, MIL-STD-348	FME-JYWHD-2	

### 2.2.2.1. RF Connections

A wide variety of cables fitted with FME connectors is offered by Amphenol CNT.

### 2.2.2.2. RF Performances

RF performances are compliant with the ETSI recommendation GSM05.05. Listed below are the main parameters for both the Receiver and the Transmitter.

The main parameters for the Receiver are:

- GSM850/E-GSM900 Reference Sensitivity = -109dBm (typical)
- DCS1800/PCS1900 Reference Sensitivity = -108dBm (typical)
- UMTS (WCDMA) B1/B2/B5/B6/B8 Reference Sensitivity = -110dBm (typical)

The main parameters for the Transmitter are:

- Maximum output power of GSM850/E-GSM: 33dBm +/- 2dB at ambient temperature
- Maximum output power of DCS1800/PCS1900: 30dBm +/- 2dB at ambient temperature
- Maximum output power of UMTS (WCDMA) B1/B2/B5/B6/B8: 23 dBm (+/- 2dBm) Class 3bis

### 2.2.2.3. Antenna Specifications

The antenna should fulfill the requirements listed in the table below.

The optimum operating frequency will depend on the application. A penta-band antenna will work in the following frequency bands and should have the following characteristics.

Table 11. Antenna Specifications

Characteristics	GSM850 and WCDMA B5/B6	EGSM900 and WCDMA B8	DCS1800	PCS1900 and WCDMA B2	WCDMA B1
<b>TX Frequency</b>	824 to 849 MHz	880 to 915 MHz	1710 to 1785 MHz	1850 to 1910 MHz	1920 to 1980 MHz
<b>RX Frequency</b>	869 to 894 MHz	925 to 960 MHz	1805 to 1880 MHz	1930 to 1990 MHz	2110 to 2170 MHz

Characteristics		GSM850 and WCDMA B5/B6	EGSM900 and WCDMA B8	DCS1800	PCS1900 and WCDMA B2	WCDMA B1
Impedance		50Ω				
VSWR	Rx max	1.5:1				
	Tx max	1.5:1				
Typical radiated gain		0dBi in one direction at least				

---

*Note: Both mechanical and electrical antenna adaptations are key issues in the design of the terminal.*

*It is strongly recommended to work with an antenna manufacturer to either develop an antenna adapted to the application or to adapt an existing solution to the application.*

---

## >> 3. Using the GL8200

### 3.1. Getting Started

To setup the GL8200, follow the procedures shown below.

1. Insert the SIM card into the SIM card socket. (Refer to section 3.1.1 Inserting the SIM Card and 3.1.2 Extracting the SIM Card for more details on how to insert and extract the SIM card from the GL8200.)



2. Connect the antenna to the FME RF connector.



3. Plug the power supply cable into the GL8200 and switch on the external power supply source.



---

**Note:** For automotive applications, it is recommended to connect the VIN-VBUS line of the GL8200 directly to the positive terminal of the battery.

---

### 3.1.1. Inserting the SIM Card

In order to insert the SIM card into the GL8200, follow the procedure shown below.

1. Prepare the SIM card in the correct position as shown in the figure.



2. Slide the SIM card into the SIM holder.



3. Use a tool to help push the SIM card into the SIM holder. Push the SIM card all the way in until you hear a clicking sound.



### 3.1.2. Extracting the SIM Card

In order to extract the SIM card from the GL8200, follow the procedure shown below.

1. Use a tool to further push the SIM card into the SIM holder. Push until you hear a clicking sound.



2. The SIM card should spring out a little bit after the clicking sound.



3. Extract the SIM card from the GL8200.



## 3.2. Operational Status

The GL8200's operational status is defined by an LED, which is located next to the SIM connector on the modem's panel. Refer to section 2.1.2 Flash LED for more information.



## 4. Communicating with the GL8200

After setting up the GL8200, communications can be established by directly sending AT commands to the device using terminal software such as HyperTerminal for MS Windows. The following subsections describe how this is done.

### 4.1. Communications Testing

#### 4.1.1. Default Serial Interface

The default serial interface is 2-wire. To perform a communications test after the GL8200 has been setup, do the following:

- Connect the RS232 link between the external application (DTE) and the GL8200 (DCE).
- Configure the RS232 port of the DTE as follows:
  - Bits per second: 115,200 bps
  - Data bits: 8
  - Parity: None
  - Stop bits: 1
  - Flow control: None
- Using a communication software such as HyperTerminal, enter:  
**AT**↵
- When communications have been established, the GL8200 will respond with an “OK”, which is displayed in the HyperTerminal window.

If communications cannot be established with the GL8200, do the following:

- Check the RS232 connection between the application (DTE) and the GL8200 (DCE).
- Check the configuration of the port COM used on the DTE

#### 4.1.2. Flow Control Option

To activate hardware flow control in 5-wire and 4-wire serial interfaces, do the following:

- Configure the RS232 port of the DTE as follows:
  - Bits per second: 115,200 bps
  - Data bits: 8
  - Parity: None
  - Stop bits: 1
  - Flow control: hardware
- Using a communication software such as HyperTerminal, enter:  
**AT&K3**↵ and **AT&W0**↵

For more information about AT commands applicable to the GL8200, please refer to the commands marked as supported by HL8548 in document [2] AirPrime HL6 and HL8 Series AT Commands Interface Guide.

## 4.2. Checking the PIN Code Status

To check if a pin code has been entered, do the following:

- Using a communication software such as HyperTerminal, enter the AT command **AT+CPIN?**
- Refer to the table below for the meaning of the AT command response.

Table 12. AT+CPIN Responses

AT+CPIN Responses	Description
+CPIN: READY	PIN Code has been entered
+CPIN: SIM PIN	PIN Code has not been entered

For more information about AT commands applicable to the GL8200, please refer to the commands marked as supported by HL8548x in document [2] AirPrime HL6 and HL8 Series AT Commands Interface Guide.

## 4.3. Verify the Received Signal Strength

The GL8200 establishes a call only if the received signal is sufficiently strong. To verify the received signal strength, do the following:

- Using a communication software such as HyperTerminal, enter the AT command **AT+CSQ**. The response returned has the following format:  
**+CSQ: <rssi>, <ber>** with:  
     <rssi> = received signal strength indication  
     <ber> = channel bit error rate
- Verify the <rssi> value returned using the table below.

Table 13. Received Signal Strength Values

Value of Received Signal Strength Indication (<rssi>)	Interpretation of the Received Signal Strength
0 – 10	Insufficient*
11 – 31	Sufficient*
32 – 98	Not defined
99	No measure available

\* Based on general observations.

For more information about AT commands applicable to the GL8200, please refer to the commands marked as supported by HL8548x in document [2] AirPrime HL6 and HL8 Series AT Commands Interface Guide.

## 4.4. Verify the Network Registration

To verify the GL8200's network registration, ensure that a valid SIM card has been inserted into the GL8200 SIM card holder (when using Embedded SIM, verify that the device has been registered by the network provider) and do the following:

- Using a communication software such as HyperTerminal, enter the following AT commands:

**AT+CPIN="xxxx"** (to enter PIN code xxxx)

**AT+CREG?** (to ascertain the registration status)

The response returned has the following format:

**+CREG: <mode>,<stat>** where:

**<mode>** = unsolicited registration message configuration

**<stat>** = registration state

- Verify the state of registration according to the returned values given in the table below.

Table 14. Network Registration Values

Returned Values <mode>,<stat>	Network Registration
+CREG: 0,0	No (not registered)
+CREG: 0,1	Yes (registered, home network)
+CREG: 0,5	Yes (registered, roaming)

For more information about AT commands applicable to the GL8200, please refer to the commands marked as supported by HL8548x in document [2] AirPrime HL6 and HL8 Series AT Commands Interface Guide.

If the GL8200 is not registered on the network, perform the following procedures:

- Check the connection between the GL8200 and the antenna.
- Verify the signal strength to determine the received signal strength (refer to section 4.3 Verify the Received Signal Strength for more information).

## 4.5. Main AT Commands for the GL8200

The table below lists the main AT commands required for starting the GL8200.

Table 15. Main AT Commands for the GL8200

Description	AT Commands	Response	Notes
Enter PIN code	<b>AT+CPIN="xxxx"</b> (xxxx = PIN code)	OK	PIN Code is accepted.
		<b>+CME ERROR: 16</b>	Incorrect PIN Code (with +CMEE = 1 mode)*
		<b>+CME ERROR: 3</b>	PIN code has already been entered (with +CMEE = 1 mode)*

Description	AT Commands	Response	Notes
Network registration checking	<b>AT+CREG?</b>	<b>+CREG: 0,1</b>	The GL8200 is registered on the network.
		<b>+CREG: 0,2</b>	The GL8200 is not registered on the network, registration is being attempted.
		<b>+CREG: 0,0</b>	The GL8200 is not registered on the network, registration is not being attempted.
Receiving an incoming call	<b>ATA</b>	<b>OK</b>	Answer the call.
Initiate a call	<b>ATD&lt;phone number&gt;;</b> (Do not forget the « ; » at the end for « voice » call)	<b>OK</b>	Communications is established.
		<b>+CME ERROR: 11</b>	PIN code was not entered (with <b>+CMEE = 1</b> mode).
		<b>+CME ERROR: 3</b>	AOC credit is exceeded or communications is already established.
Initiate an emergency call	<b>ATD112 ;</b> (Do not forget the « ; » at the end for « voice » call)	<b>OK</b>	Communications is established.
Communication loss		<b>NO CARRIER</b>	
Hang up	<b>ATH</b>	<b>OK</b>	
Store the parameters in EEPROM	<b>AT&amp;W</b>	<b>OK</b>	The configuration settings are stored in non-volatile memory (EEPROM).

\* The command **AT+CMEE=1** switches to a mode enabling more complete error diagnostics.

For more information about AT commands applicable to the GL8200, please refer to the commands marked as supported by HL8548x in document [2] AirPrime HL6 and HL8 Series AT Commands Interface Guide.

## 4.6. Echo Function

If no echo is displayed when entering an AT command, it could mean either of the following:

- The "local echo" parameter of your communication software such as HyperTerminal, is disabled.
- The GL8200 echo function is disabled.

To enable the GL8200 echo function, enter **ATE1**.

When sending AT commands to the GL8200 through a communication software such as HyperTerminal, it is recommended to:

- Disable the "local echo" parameter of your communication software
- Enable the GL8200 echo function (**ATE1** command)

In a machine-to-machine communication with the GL8200, it is recommended to disable the GL8200 echo function (**ATE0** command) in order to avoid useless CPU processing.

For more information about AT commands applicable to the GL8200, please refer to the commands marked as supported by HL8548x in document [2] AirPrime HL6 and HL8 Series AT Commands Interface Guide.



## 5. Troubleshooting the GL8200

This section of the document describes possible problems that might be encountered when using the GL8200 and their corresponding solutions.

To read about other troubleshooting information, refer to the [Sierra Wireless Source](#).

### 5.1. No Communications with the GL8200 through the Serial Link

If the GL8200 does not answer to AT commands through the serial link, refer to the table below for possible causes and their corresponding solutions.

Table 16. Solutions for No Connection with the GL8200 through the (2-wire) Serial Link

If the GL8200 returns	Then ask	Action
Nothing	Is the GL8200 powered correctly?	Make sure that the external power supply is connected to the GL8200 and provides a voltage within the range of 4.75V to 32V.
	Is the serial cable connected at both sides?	Check the serial cable connection.
	Does the serial cable correctly follow the pin assignments as shown in section 2.2.1 8-pin Micro-Fit Connector?	Connect the cable by following the pin assignments as given in section 2.2.1 8-pin Micro-Fit Connector.
Nothing or non-significant characters	Is the communication program properly configured on the PC?	Ensure that the settings of the communication program are compatible with the settings of the GL8200.  The GL8200 factory settings are: <ul style="list-style-type: none"><li>• Data bits = 8</li><li>• Parity = none</li><li>• Stop bits = 1</li><li>• Baud = 115200 bps</li><li>• Flow control = none</li></ul>
	Is there another program interfering with the communication program (i.e. conflict on communication port access)?	Close the interfering program.

## 5.2. Receiving an “ERROR” Message

The GL8200 returns an "ERROR" message (in reply to an AT command) in the following cases:

- The AT command syntax is incorrect. In this case, check the command syntax applicable to the HL8548x as specified in document [2] AirPrime HL6 and HL8 Series AT Commands Interface Guide.
- The AT command syntax is correct, but was transmitted using the wrong parameters:
  - Enter the **AT+CMEE=1** command in order to change the error report method to the verbose method, which includes the error codes.
  - Re-enter the AT command which previously caused the reception of an "ERROR" message in order to get the Mobile Equipment error code.

When the verbose error report method is enabled, the response of the GL8200 in case of error is either:

- **+CME ERROR: <error result code>**
- or
- **+CMS ERROR: <error result code>**

For more information on error result code description and further details on the **AT+CMEE** command that are applicable to the GL8200, please refer to the commands marked as supported by HL8548x in document [2] AirPrime HL6 and HL8 Series AT Commands Interface Guide.

---

**Tip:** *It is strongly recommended to always enable the verbose error report method to get the Mobile Equipment error code (enter the **AT+CMEE=1** command).*

---

## 5.3. Receiving a “NO CARRIER” Message

If the GL8200 returns a "NO CARRIER" message upon an attempted call (voice or data), refer to the table below for possible causes and their corresponding solutions.

Table 17. Solutions for Receiving a “NO CARRIER” Message

If the GL8200 returns	Then ask	Action
"NO CARRIER"	Is the received signal strong enough?	Refer to section 4.3 Verify the Received Signal Strength to verify the strength of the received signal.
	Is the GL8200 registered on the network?	Refer to section 4.4 Verify the Network Registration to verify the network registration.
	Is the antenna properly connected?	Refer to section 2.2.2.3 Antenna Specifications for antenna requirements.
"NO CARRIER" (when trying to issue a voice communication)	Is the semicolon (;) entered immediately after the phone number in the AT command?	Ensure that the semicolon (;) is entered immediately after the phone number in the AT command.  e.g. <b>ATD#####;</b>

If the GL8200 returns	Then ask	Action
"NO CARRIER" (when trying to issue a data communication)	Is the SIM card configured for data/fax calls?	Configure the SIM card for data/fax calls. (Ask your network provider if necessary).
	Is the selected bearer type supported by the called party?	Ensure that the selected bearer type is supported by the called party.
	Is the selected bearer type supported by the network?	Ensure that the selected bearer type is supported by the network. If still unsuccessful, try selecting the bearer type using the AT command: <b>AT+CBST=0,0,3</b>

If the GL8200 returns a "NO CARRIER" message, you may retrieve the extended error code by using the AT command **AT+CEER**. Refer to the table below for the interpretation of extended error codes.

Table 18. Extended Error Codes

Error Code	Diagnosis	Hint
1	Unallocated phone number	
16	Normal call clearing	
17	User busy	
18	No user responding	
19	User alerting, no answer	
21	Call rejected	
22	Number changed	
31	Normal, unspecified	
50	Requested facility not subscribed	Check your subscription. (Is data subscription available?)
68	ACM equal or greater than ACMmax	The credit of your pre-paid SIM card has expired.
252	Call barring on outgoing calls	
253	Call barring on incoming calls	
3, 6, 8, 29, 34, 38, 41, 42, 43, 44, 47, 49, 57, 58, 63, 65, 69, 70, 79, 254	Network causes	For more information about AT commands applicable to the GL8200, please refer to the commands marked as supported by HL8548x in document [2] AirPrime HL6 and HL8 Series AT Commands Interface Guide or call your network provider.

For all other codes and their corresponding details applicable to the GL8200, refer to the commands marked as supported by the HL8548x in document [2] AirPrime HL6 and HL8 Series AT Commands Interface Guide.

## 5.4. Resetting the GL8200

Resetting the GL8200 could be triggered by the AT command **AT+CFUN=1,1**, or it could be done by simply unplugging and then re-plugging the power supply (VIN-VBUS).

## >> 6. Power Consumption

### 6.1. Consumption Measurement Procedure

This chapter describes the procedure for consumption measurement which is used to obtain the modem's consumption specifications.

The modem consumption specification values are measured for all operating modes available on this product. For more information about the different operating modes, refer to section 6.2 Operating Modes.

Consumption results are highly dependent on the hardware configuration used during measurement and the following chapter describes the hardware configuration settings that should be used to obtain optimum consumption measurements.

#### 6.1.1. Hardware Configuration

The following hardware configuration includes both the measurement equipment and the modem.

##### 6.1.1.1. Equipment

Three devices are used to perform consumption measurement:

- A communication tester
- A current measuring power supply
- A computer, to control the modem and to save measurement data

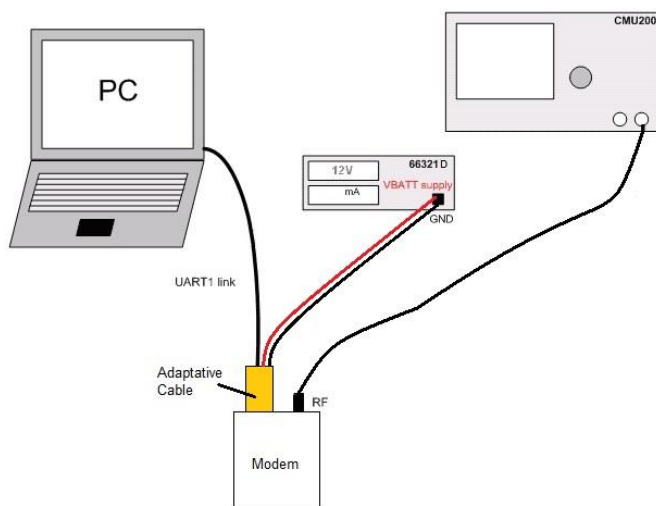

Figure 10. Typical Hardware Configuration

The communication tester is a CMU 200 from Rhode & Schwartz. This tester offers all required GSM/GPRS and WCDMA network configurations and allows a wide range of network configurations to be set.

The 66321D power supply is used to supply the modem, and it could also be used to measure the total current drain by the device. The “current measuring power supply” is also connected and controlled by the computer (GPIO control not shown in the previous figure).

Note that a SIM must be inserted during all consumption measurements.

The following table lists the recommended equipment to use for the consumption measurement.

**Table 19. List of Recommended Equipment**

Device	Manufacturer	Part Number	Notes/Description
Communication Tester	Rhode & Schwartz	CMU 200	GSM Quad Band + WCDMA (B1/B2/B5/B6/B8)
Current measuring power supply	Agilent	66321D	Used for VIN-VBUS

### 6.1.1.2. SIM Cards

Consumption measurement may be performed with either 3-Volt or 1.8-Volt SIM cards. However, all specified consumption values are for a 3-Volt SIM card.

---

*Note: The SIM card's voltage is supplied by the modem power supply. Consumption measurement results may vary depending on the SIM card.*

---

## 6.1.2. Software Configuration

This section describes the modem settings and software configuration for the equipment used.

### 6.1.2.1. Modem Configuration

The software configuration is done by selecting the operating mode to use in performing the measurement. Refer to section 6.2 Operating Modes for more information.

Refer to the following list for the available operating modes on the modem:

- ACTIVE Mode
- SLEEP Mode
- Communication Mode
- Transfer Mode class 10 (3Rx/2Tx) (in GPRS mode)
- HSDPA (B1/B2/B5/B6/B8)
- HSUPA (B1/B2/B5/B6/B8)

### 6.1.2.2. Equipment Configuration

The communication tester is set according to the operating mode. Paging during idle modes, Tx burst power, RF band and GSM/DCS/PCS/GPRS/WCDMA may be selected on the communication tester.

## 6.2. Operating Modes

Power consumption levels of the modem also vary depending on the operating mode used.

Refer to the table below for the different kinds of operating modes available.

Table 20. Operating Modes

Mode	Description
OFF Mode	Not Supported. When VIN-VBUS power is supplied to the modem, it will be automatically powered ON.
Alarm Mode	Not Supported. The ON/OFF switch is always LOW in this application.
ACTIVE Mode	Default mode. No functional restrictions.
SLEEP Mode	When the modem has a location update with a live network but with no GSM/GPRS/WCDMA connection, while the serial link interface is NOT available.
Communication Mode	When the modem supporting a GSM/WCDMA voice codec connection with a live network with DTMF support.
Transfer Mode	When the modem has a GPRS data transfer connection with a live network.
HSDPA	Maximum output power based on TS34.121 Section 5.2AA
HSUPA	Maximum output power based on TS34.121 Section 5.2B

### 6.2.1. Entering Sleep Mode

AT command **AT+KSLEEP** enables the sleep mode configuration below.

#### **AT+KSLEEP=0**

- The modem is active when DTR signal is active (low electrical level).
- When DTR is deactivated (high electrical level), the modem enters sleep mode after a while.
- On DTR activation (low electrical level), the modem wakes up.

#### **AT+KSLEEP=1**

- The modem determines when it enters sleep mode (when no more tasks are running).
- "0x00" character on the serial link wakes the modem up.

#### **AT+KSLEEP=2**

- The modem never enters sleep mode.

In sleep mode, the modem reduces its power consumption and remains waiting for the wake-up signals either from the network (i.e. read paging block depending on the DRX value of the network) or the operating system (i.e. timers wake up timers activated) or the host controller (i.e. character on serial link or DTR signal).

For more details about the **AT+KSLEEP** command, please refer to document [2] AirPrime HL6 and HL8 Series AT Commands Interface Guide.

## 6.2.2. Serial Port Shutdown Mode

The modem could be configured to shut down the serial link interface while there is no traffic on the serial link channel by the following AT command:

- Enabling Serial Port Shutdown Mode
  - **AT+KGPIOCFG=7,0,2** //set GPIO7 as an output
  - **AT+KGPIO=7,1** //set GPIO7 output high
  
- Disabling Serial Port Shutdown Mode
  - **AT+KGPIOCFG=7,0,2** //set GPIO7 as an output
  - **AT+KGPIO=7,0** //set GPIO7 output low

For more information about AT commands applicable to the GL8200, please refer to the commands marked as supported by HL8548x in document [2] AirPrime HL6 and HL8 Series AT Commands Interface Guide.

The Serial Port Shutdown Mode will be immediately activated after the AT command set. To wake the modem up from this mode, just simply set the DTR pin to HIGH.

---

*Note:* A 4-wire serial interface can only support this feature if DTR is managed. A 2-wire serial interface, on the other hand, cannot support this feature. Attempting to enable it will lead to termination of communication with the modem.

---

## 6.3. Power Consumption Values

These consumption values were obtained by performing measurements on samples at a temperature of 25°C with the assumption of a 50Ω RF output.

Three DC inputs (VIN-VBUS) were used to measure the consumption: VinMIN (4.75V), VinTYP (12V) and VinMAX (32V). Both the average current and maximum current peaks were also measured.

Note that power consumption performance is also software related.

---

*Note:* TX = the current peak is the RF transmission burst (Tx burst)  
RX = the current peak is the RF reception burst (Rx burst)

---

Table 21. Power Consumption (Typical Values)

Working Modes	Parameters	I <sub>average</sub>			Unit
		Vin = 32V	Vin = 12V	Vin = 4.75V	
ACTIVE Mode	GSM DRX9 (Rx burst occurrence ~2s)	8.11	16.58	30.62	mA
	GSM DRX2 (Rx burst occurrence ~0,5s)	8.12	16.68	30.84	mA
	WCDMA DRX9	8.07	16.41	31.00	mA
	WCDMA DRX6	8.12	16.54	31.70	mA

Working Modes	Parameters	I <sub>average</sub>			Unit
		V <sub>in</sub> = 32V	V <sub>in</sub> = 12V	V <sub>in</sub> = 4.75V	
SLEEP Mode	Paging 9 (Rx burst occurrence ~2s)	2.48	2.73	3.99	mA
	Paging 2 (Rx burst occurrence ~0,5s)	2.54	2.89	4.29	mA
	WCDMA DRX9	2.49	2.67	3.92	mA
	WCDMA DRX6	2.61	3.01	4.51	mA
Communication Mode	850/900 MHz – PCL5 (TX power 33dBm)	44.5	106.9	267.9	mA
	850/900 MHz – PCL19 (TX power 5dBm)	13.8	28.5	58.1	mA
	1800/1900 MHz – PCL0 (TX power 30dBm)	31.6	72.4	173.9	mA
	1800/1900 MHz – PCL15 (TX power 0dBm)	13.7	27.9	57.1	mA
Transfer Mode class 10 (3Rx/2Tx)	850/900 MHz – gam. 3 (TX power 33dBm)	77.7	189.3	486.6	mA
	850/900 MHz – gam. 17 (TX power 5dBm)	18.6	39.0	82.3	mA
	1800/1900 MHz – gam. 3 (TX power 30dBm)	52.2	123.7	304.5	mA
	1800/1900 MHz – gam. 18 (TX power 0dBm)	18.5	38.4	81.0	mA
WCDMA communication mode (RMC, TS34.121 Section 5.2)	Band 1	98.6	232.3	566.3	mA
	Band 2	85.4	200.8	495.5	mA
	Band 5 / 6	76.0	180.6	436.5	mA
	Band 8	97.0	232.4	580.8	mA
HSDPA (TS34.121 Section 5.2AA)	Band 1	108.7	247.8	669.7	mA
	Band 2	105.8	242.8	654.3	mA
	Band 5 / 6	101.4	222.5	600.3	mA
	Band 8	122.5	288.2	803.7	mA
HSUPA (TS34.121 Section 5.2B)	Band 1	106.4	243.3	663.3	mA
	Band 2	105.9	241.4	651.3	mA
	Band 5 / 6	97.7	225.2	607.7	mA
	Band 8	119.9	269.1	795.0	mA
Maximum Peak current	GSM900 / GSM850	-	-	1.8	A
	DCS / PCS	-	-	1.7	A

# 7. Reliability Compliance and Recommendations

## 7.1. Environmental Specifications

The modem is compliant with the following operating classes. The table below lists the ideal temperature range of the environment.

Table 22. Operating Class Temperature Range

Conditions	Temperature Range
Operating/Class A	-20 °C to +55°C
Operating/Class B	-30 °C to +75°C
Storage	-40 °C to +80°C

### 7.1.1. Function Status Classification

The classes reported below comply with the Annex “ISO Failure Mode Severity Classification”, ISO Standard 7637, and Section 1.

---

*Note: The word “function” as used here concerns only the function performed by the modem.*

---

Table 23. ISO Failure Mode Severity Classification

Class	Definition
CLASS A	The modem remains fully functional during and after environmental exposure; and shall meet the minimum requirements of 3GPP or appropriate wireless standards.
CLASS B	The modem remains fully functional during and after environmental exposure; and shall exhibit the ability to establish a voice, SMS or DATA call at all times even when one or more environmental constraint exceeds the specified tolerance. Unless otherwise stated, full performance should return to normal after the excessive constraint(s) have been removed.

## 7.2. Reliability Prediction Model

### 7.2.1. Life Stress Test

The following tests the product performance.



Table 24. Life Stress Test

Designation	Condition
<b>Performance Test</b> 	Standard: N/A
	Special conditions: <ul style="list-style-type: none"> <li>• Temperature:                             <ul style="list-style-type: none"> <li>▪ Class A: -20°C to +55°C</li> <li>▪ Class B: -30°C to +75°C</li> </ul> </li> <li>• Rate of temperature change: 3°C/min</li> <li>• Recovery time: 20 mins</li> </ul>
	Operating conditions: Powered
	Duration: Varies

### 7.2.2. Environmental Resistance Stress Tests

The following tests the modem’s resistance to extreme temperature.

Table 25. Environmental Resistance Stress Tests

Designation	Condition
<b>Cold Test</b> 	Standard: IEC 680068-2-1, Test Ad
	Special conditions: <ul style="list-style-type: none"> <li>• Temperature: -30°C</li> <li>• Rate of temperature change: 1°C/min</li> <li>• Recovery time: 3 hours</li> </ul>
	Operating conditions: Powered
	Duration: 72 hours
<b>Resistance to Heat</b> 	Standard: IEC 680068-2-2, Test Bb
	Special conditions: <ul style="list-style-type: none"> <li>• Temperature: 80°C</li> <li>• Rate of temperature change: 1°C/min</li> </ul> Recovery time: 3 hours
	Operating conditions: Powered
	Duration: 50 days

### 7.2.3. Corrosive Resistance Stress Test

The following tests the modem’s resistance to corrosive atmosphere.

Table 26. Corrosive Resistance Stress Test

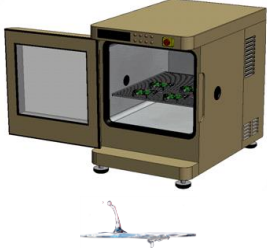
Designation	Condition
<b>Humidity Test</b> 	Standard: IEC 60068-2-3, Test Ca
	Special conditions: <ul style="list-style-type: none"> <li>• Temperature: 65°C</li> <li>• RH: 95%</li> <li>• Rate of temperature change: 3°C/min</li> <li>• Recovery time: 3 hours</li> </ul>
	Operating conditions: Powered
	Duration: 10 days

### 7.2.4. Thermal Resistance Cycle Stress Test

The following tests the modem resistance to extreme temperature cycling.

Table 27. Thermal Resistance Cycle Stress Test

Designation	Condition
<b>Thermal Shock Test</b> 	Standard: IEC 60068-2-14, Test Na
	Special conditions: <ul style="list-style-type: none"> <li>• Upper temperature: 85°C</li> <li>• Lower temperature: -40°C</li> <li>• Rate of temperature change: 30s</li> <li>• Number of cycles: 300</li> <li>• Duration of exposure: 20 minutes</li> <li>• Recovery time: 3 hours</li> </ul>
	Operating conditions: Un-powered
	Duration: 9 days

## 7.2.5. Mechanical Resistance Stress Tests

The following tests the modem's resistance to vibrations and mechanical shocks.

Table 28. Mechanical Resistance Stress Tests

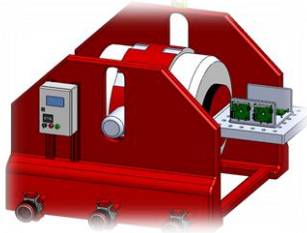
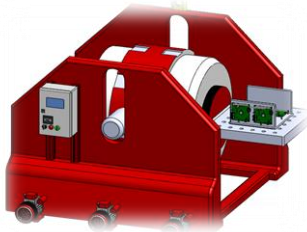
Designation	Condition
<p><b>Sinusoidal Vibration Test SVT</b></p> 	<p>Standard: IEC 60068-2-6, Test Fc</p> <p>Special conditions:</p> <ul style="list-style-type: none"> <li>• Frequency range: 16Hz to 1000Hz                             <ul style="list-style-type: none"> <li>▪ Displacement: <math>\pm 0.35\text{mm}</math> (peak-peak)</li> </ul> </li> <li>• Frequency range: 16Hz to 62Hz                             <ul style="list-style-type: none"> <li>▪ Acceleration: 5G</li> </ul> </li> <li>• Frequency range: 62Hz to 200Hz                             <ul style="list-style-type: none"> <li>▪ Acceleration: 3G</li> </ul> </li> <li>• Frequency range: 200Hz to 1000Hz                             <ul style="list-style-type: none"> <li>▪ Acceleration: 1G</li> </ul> </li> <li>• Sweep rate: 1 octave/min</li> <li>• Test duration: 20 cycles</li> <li>• Sweep directions: X, Y and Z</li> </ul> <p>Operating conditions: Un-powered</p> <p>Duration: 48 hours</p>
<p><b>Random Vibration Test RVT</b></p> 	<p>Standard: IEC 60068-2-64</p> <p>Special conditions:</p> <ul style="list-style-type: none"> <li>• Frequency range:                             <ul style="list-style-type: none"> <li>▪ <math>0.1\text{ g}^2/\text{Hz}</math> at 10Hz</li> <li>▪ <math>0.01\text{ g}^2/\text{Hz}</math> at 250Hz</li> <li>▪ <math>0.005\text{ g}^2/\text{Hz}</math> at 1000Hz</li> <li>▪ <math>0.005\text{ g}^2/\text{Hz}</math> at 2000Hz</li> </ul> </li> <li>• Peak factor: 3</li> <li>• Duration per axis: 1 hr</li> <li>• Number of axis: 3 (X, Y and Z)</li> </ul> <p>Operating conditions: Un-powered</p> <p>Duration: 24 hours</p>

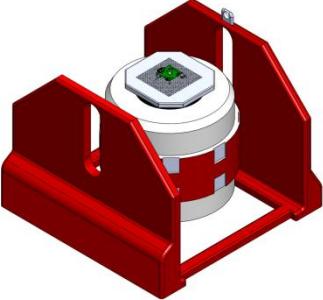
Designation	Condition
<b>Mechanical Shock Test MST</b> 	Standard: IEC 60068-2-27, Test Ea
	Special conditions: <ul style="list-style-type: none"> <li>• Shock Test 1:                             <ul style="list-style-type: none"> <li>▪ Wave form: Half Sine</li> <li>▪ Peak acceleration: 30G</li> <li>▪ Duration: 11ms</li> <li>▪ Number of shocks: 8 per direction</li> <li>▪ Number of directions: 6 (<math>\pm X, \pm Y, \pm Z</math>)</li> </ul> </li> <li>• Shock Test 2:                             <ul style="list-style-type: none"> <li>▪ Wave form: Half Sine</li> <li>▪ Peak acceleration: 100G</li> <li>▪ Duration: 6ms</li> <li>▪ Number of shocks: 3 per direction</li> <li>▪ Number of directions: 6 (<math>\pm X, \pm Y, \pm Z</math>)</li> </ul> </li> </ul>
	Operating conditions: Un-powered
	Duration: 72 hours

### 7.2.6. Handling Resistance Stress Tests

The following tests the modem’s resistance to handling malfunctions and damage.

Table 29. Handling Resistance Stress Tests

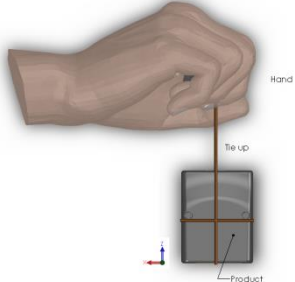
Designation	Condition
<b>ESD Test</b> 	Standard: IEC 61000-4-2
	Special conditions: <ul style="list-style-type: none"> <li>• Contact discharges: 10 positive and 10 negative applied (Voltage: <math>\pm 2kV, \pm 4kV, \pm 6kV</math>)</li> <li>• Air discharges: 10 positive and 10 negative applied (Voltage: <math>\pm 2kV, \pm 4kV, \pm 8kV</math>)</li> </ul>
	Operating conditions: Powered
	Duration: 72 hours
<b>Free Fall Test FFT</b> 	Standard : IEC 60068-2-32, Test Ed
	Special conditions: <ul style="list-style-type: none"> <li>• Drop: 2 samples for each direction</li> <li>• Equivalent drop height: 1m</li> <li>• Number of directions: 6 (<math>\pm X, \pm Y, \pm Z</math>)</li> <li>• Number of drops/face: 2</li> </ul>
	Operating conditions: Un-powered
	Duration: 24 hours



## 8. Certification Compliance and Recommended Standards

The GL8200 is compliant with the following requirements.

Table 30. Standards Conformity for the GL8200

Domain	Applicable Standard
Safety standard	EN 60950-1:2006 +A11:2009 +A1:2010 +A12:2011 AS/NZS 60950.1:2003 Amdt 1:2006 Amdt 2:2008 Amdt 3:2008
Health standard (EMF Exposure Evaluation)	EN 62311 (ed. 2008)
Efficient use of the radio frequency spectrum	EN 301 511 (v9.0.2) EN 301 908-1 (v6.2.1) EN 301 908-2 (v6.2.1) AS/CA S042.1:2010 AS/CA S042.4-2011 AS/ACIF S042.3:2005
EMC	EN 301 489-1 (v1.9.2) EN 301 489-3 (v1.6.1) EN 301 489-7 (v1.3.1) EN 301 489-24 (v1.5.1)

## 9. Cables and Accessories

### 9.1. Adaptive Cable

The adaptive cable provides a serial interface and is used as the power source of the GL8200. It has three edges/plugs.

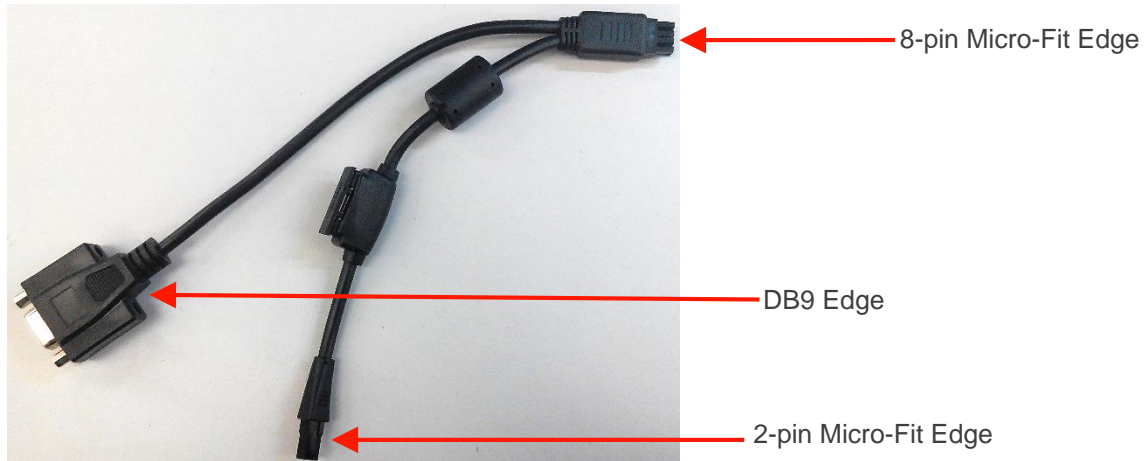

Figure 11. Adaptive Cable for the GL8200

#### 9.1.1. 8-pin Micro-Fit Edge

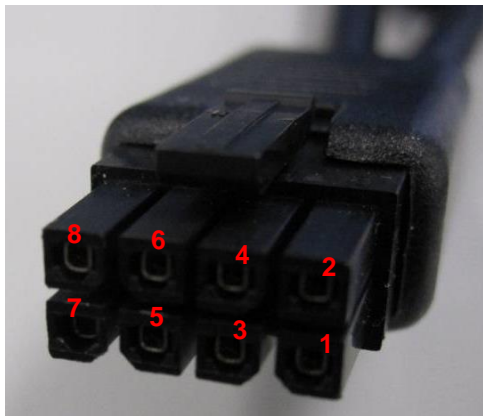

Figure 12. 8-pin Micro-Fit Edge of the Adaptive Cable

Refer to the following table for the pin description of the 8-pin Micro-Fit Edge of the Adaptive cable.

Table 31. 8-pin Micro-Fit Pin Description of the Adaptive Cable

Pin Number	Signal	Description
1	RS232-CTS	Main RS232 Clear To Send
2	RS232-RTS	Main RS232 Request To Send

Pin Number	Signal	Description
3	RS232-RXD	Main RS232 Receive Serial Data
4	RS232-TXD	Main RS232 Transmit Serial Data
5	RS232-DTR	Main RS232 Data Terminal Ready
6	GND	Ground Connection
7	Vin	Power Supply with a 4.75 – 32V DC input
8	GND	Ground Connection

Refer to Table 6 Micro-Fit Connector Pin Description for more information about the pin assignments and description.

### 9.1.2. DB9 Edge



Figure 13. DB9 Edge of the Adaptation Cable

Refer to the following table for the pin description of the DB9 Edge of the Adaptation cable.

Table 32. DB9 Connector Pin Description

Pin Number	Signal	Description
1	Not Connected	
2	RS232 – RXD	Output Data to DTE
3	RS232 – TXD	Input Date from DTE
4	RS232 – DTR	Input Signal from DTE
5	GND	Ground Connection
6	Not Connected	
7	RS232 – RTS	Flow Control Signal from DTE
8	RS232 – CTS	Flow Control Signal to DTE
9	Not Connected	

### 9.1.3. 2-pin Micro-Fit Edge

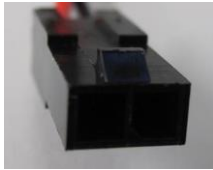

Figure 14. 2-pin Micro-Fit Edge of the Adaptive Cable

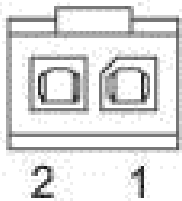

Figure 15. Pin Assignment of the 2-pin Micro-Fit Edge

Refer to the following table for the pin description of the 2-pin Micro-Fit Edge of the Adaptive cable.

Table 33. 2-pin Micro-Fit Connector Pin Description

Pin Number	Signal	Description
1	GND	Ground Connection
2	Vin	4.75V to 32V

## 9.2. DC Cable

This cable supplies the power source for the GL8200, and is used with the Adaptive cable.



Figure 16. DC Cable

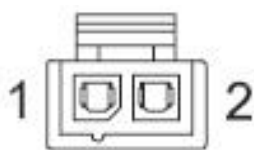

Figure 17. Pin Assignment of the DC Cable

Table 34. DC Cable Pin Description

Pin Number	Signal	Description
1	GND	Black color
2	Vin	Red color

## 9.3. Antenna

Sierra Wireless recommends using antennas from PULSE for use with the GL8200. Refer to the following table for the specifications of the specific antenna recommended.

Table 35. Recommended Antenna Description

Attribute	Value
Item Number	W1903
Frequency	850/900/1800/1900/2100MHz
Maximum Gain (peak)	2.5dBi
VSWR	< 2:1
Polarization	Vertical
Impedance	50Ω

# 10. Mechanical Constraints

## 10.1. Micro-Fit Connector

The following table lists the mechanical constraints that must be taken into account when using the 8-pin Micro-Fit connector.

Table 36. Micro-Fit Connector Mechanical Constraints

Description	Mechanical Limit	Notes
Connector Mate and Unmate Forces	MINIMUM withdrawal force: 3.7N (0.8lbf)	This is the least amount of force needed to unplug the cable from the 8-pin Micro-Fit connector.
	MAXIMUM insertion force: 8.0N (1.8lbf)	This is the maximum amount of force that should be used when inserting a male connector into the 8-pin Micro-Fit connector. Using force greater than this might damage the Micro-Fit connector.
Terminal Retention Force (in housing)	MINIMUM retention force: 24.5N (5.5lbf)	This is the least amount of force needed to keep the power supply cable connected to the 8-pin Micro-Fit connector.
Terminal Insertion Force (into housing)	MAXIMUM insertion force: 14.7N (3.3lbf)	This is the maximum amount of force that should be used when pushing in the power supply cable into the 8-pin Micro-Fit connector. Using force greater than this might damage the Micro-Fit connector.

## 10.2. FME RF Connector

The following table lists the mechanical constraints that must be taken into account when using the FME RF connector.

Table 37. FME RF Connector Mechanical Constraints

<b>Mating Force</b>	M8XP .75 thd.
---------------------	---------------

# 11. Protections

## 11.1. Power Supply

Sierra Wireless recommends having a 1000mA/250V slow break fuse bonded to the power supply cable which can protect the modem's internal electronic components from over-current consumption.

## 11.2. Electrostatic Discharge

The GL8200 withstands ESD according to IEC 1000-4-2 requirements for all accessible parts of the GL8200 except the RF part, which only protects:

- +/-8kV of air discharge
- +/-4kV of contact discharge

## 11.3. Miscellaneous

The GL8200 is guaranteed to have filtering for:

- EMI/RFI protection on both the input and the output
- Signal smoothing

## 12. Upgrade Guidelines

### 12.1. Operating System Upgrade

The GL8200's operating system is stored in flash memory and can be easily upgraded.

The operating system file can be downloaded into the GL8200 using FLASH tools.

Listed below are the serial signals required to proceed the firmware upgrading:

- TXD
- RXD
- RTS
- CTS
- GND

The operating system file can also be downloaded onto the GL8200 using the DOTA (download over the air) feature. For more information about AT commands applicable to the GL8200, please refer to the commands marked as supported by HL8548x in document [2] AirPrime HL6 and HL8 Series AT Commands Interface Guide.

### 12.2. Firmware Upgrade

The firmware upgrade procedure is used to update the firmware embedded in the GL8200.

This procedure consists of downloading the firmware into internal memories through the RS232 serial link available on the Micro-fit 8-pin connector.

## >> | 13. References

For more details, several reference documents can be consulted. The Sierra Wireless documents referenced herein are provided in the Sierra Wireless documentation package; however, the general reference documents which are not Sierra Wireless owned are not provided in the documentation package.

### 13.1. Sierra Wireless Reference Documentation

Refer to your software package to determine the current version of software being used and for applicable manuals. Latest revisions and other documentation can be downloaded from [the Source](#) if needed.

- [1] AirPrime HL8548 and HL8548-G Product Technical Specification  
Reference: 4114663
- [2] AirPrime HL6 and HL8 Series AT Commands Interface Guide  
Reference: 4114680

### 13.2. General Reference Documentation

- [3] ISO 7816-3 Standard

### 13.3. List of Abbreviations

Abbreviation	Definition
AC	Alternative Current
ADC	Analog to Digital Converter
A/D	Analog to Digital conversion
AF	Audio-Frequency
AT	Attention (prefix for modem commands)
AUX	Auxiliary
CAN	Controller Area Network
CB	Cell Broadcast
CEP	Circular Error Probable
CLK	Clock
CMOS	Complementary Metal Oxide Semiconductor
CS	Coding Scheme
CTS	Clear To Send
DAC	Digital to Analogue Converter
dB	Decibel
DC	Direct Current
DCD	Data Carrier Detect
DCE	Data Communication Equipment

<b>Abbreviation</b>	<b>Definition</b>
DCS	Digital Cellular System
DR	Dynamic Range
DSR	Data Set Ready
DTE	Data Terminal Equipment
DTR	Data Terminal Ready
EFR	Enhanced Full Rate
E-GSM	Extended GSM
EMC	Electromagnetic Compatibility
EMI	Electromagnetic Interference
EMS	Enhanced Message Service
EN	Enable
ESD	Electrostatic Discharges
FIFO	First In First Out
FR	Full Rate
FTA	Full Type Approval
GND	Ground
GPI	General Purpose Input
GPC	General Purpose Connector
GPIO	General Purpose Input Output
GPO	General Purpose Output
GPRS	General Packet Radio Service
GPS	Global Positioning System
GSM	Global System for Mobile communications
HR	Half Rate
I/O	Input / Output
JTAG	Joint Test Action Group
LED	Light Emitting Diode
LNA	Low Noise Amplifier
MAX	Maximum
MIC	Microphone
MIN	Minimum
MMS	Multimedia Message Service
MO	Mobile Originated
MT	Mobile Terminated
na	Not Applicable
NF	Noise Factor
NMEA	National Marine Electronics Association
NOM	Nominal
NTC	Negative Temperature Coefficient
OTA	Over the air
PA	Power Amplifier
Pa	Pascal (for speaker sound pressure measurements)
PBCCH	Packet Broadcast Control Channel

<b>Abbreviation</b>	<b>Definition</b>
PC	Personal Computer
PCB	Printed Circuit Board
PDA	Personal Digital Assistant
PFM	Power Frequency Modulation
PSM	Phase Shift Modulation
PWM	Pulse Width Modulation
RAM	Random Access Memory
RF	Radio Frequency
RFI	Radio Frequency Interference
RHCP	Right Hand Circular Polarization
RI	Ring Indicator
RST	Reset
RTC	Real Time Clock
RTCM	Radio Technical Commission for Maritime services
RTS	Request To Send
RX	Receive
SCL	Serial Clock
SDA	Serial Data
SIM	Subscriber Identification Module
SMS	Short Message Service
SPI	Serial Peripheral Interface
SPL	Sound Pressure Level
SPK	Speaker
SW	Software
PSRAM	Pseudo Static RAM
TBC	To Be Confirmed
TDMA	Time Division Multiple Access
TP	Test Point
TVS	Transient Voltage Suppressor
TX	Transmit
TYP	Typical
UART	Universal Asynchronous Receiver-Transmitter
UMTS	Universal Mobile Telecommunications System
USB	Universal Serial Bus
USSD	Unstructured Supplementary Services Data
VSWR	Voltage Standing Wave Ratio
WCDMA	Wideband Code Division Multiple Access



## 14. Safety Recommendations (For Information Only)

For the efficient and safe operation of your GSM device, please read the following information carefully.

### 14.1. RF Safety

#### 14.1.1. General

Your GSM terminal is based on the GSM standard for cellular technology. The GSM standard is spread all over the world. It covers Europe, Asia and some parts of America and Africa. This is the most used telecommunication standard.

Your GSM terminal is actually a low power radio transmitter and receiver. It sends out and receives radio frequency energy. When you use your GSM application, the cellular system which handles your calls controls both the radio frequency and the power level of your cellular modem.

#### 14.1.2. Exposure to RF Energy

There has been some public concern about possible health effects of using GSM terminals. Although research on health effects from RF energy has focused on the current RF technology for many years, scientists have begun research regarding newer radio technologies, such as GSM. After existing research had been reviewed, and after compliance to all applicable safety standards had been tested, it has been concluded that the product was fitted for use.

If you are concerned about exposure to RF energy there are things you can do to minimize exposure. Obviously, limiting the duration of your calls will reduce your exposure to RF energy. In addition, you can reduce RF exposure by operating your cellular terminal efficiently by following the below guidelines.

#### 14.1.3. Efficient Terminal Operation

For your GSM terminal to operate at the lowest power level, consistent with satisfactory call quality:

If your terminal has an extendible antenna, extend it fully. Some models allow you to place a call with the antenna retracted. However your GSM terminal operates more efficiently with the antenna fully extended.

Do not hold the antenna when the terminal is « IN USE ». Holding the antenna affects call quality and may cause the modem to operate at a higher power level than needed.

### **14.1.4. Antenna Care and Replacement**

Do not use the GSM terminal with a damaged antenna. If a damaged antenna comes into contact with the skin, a minor burn may result. Replace a damaged antenna immediately. Consult your manual to see if you may change the antenna yourself. If so, use only a manufacturer-approved antenna. Otherwise, have your antenna repaired by a qualified technician.

Use only the supplied or approved antenna. Unauthorized antennas, modifications or attachments could damage the terminal and may contravene local RF emission regulations or invalidate type approval.

## **14.2. General Safety**

### **14.2.1. Driving**

Check the laws and the regulations regarding the use of cellular devices in the area where you have to drive as you always have to comply with them. When using your GSM terminal while driving, please:

- give full attention to driving,
- pull off the road and park before making or answering a call if driving conditions so require.

### **14.2.2. Electronic Devices**

Most electronic equipment, for example in hospitals and motor vehicles is shielded from RF energy. However RF energy may affect some improperly shielded electronic equipment.

### **14.2.3. Vehicle Electronic Equipment**

Check your vehicle manufacturer representative to determine if any on-board electronic equipment is adequately shielded from RF energy.

### **14.2.4. Medical Electronic Equipment**

Consult the manufacturer of any personal medical devices (such as pacemakers, hearing aids, etc...) to determine if they are adequately shielded from external RF energy.

Turn your terminal OFF in health care facilities when any regulations posted in the area instruct you to do so. Hospitals or health care facilities may be using RF monitoring equipment.

## 14.2.5. Aircraft

Turn your terminal OFF before boarding any aircraft.

- Use it on the ground only with crew permission
- Do not use it in the air

To prevent possible interference with aircraft systems, Federal Aviation Administration (FAA) regulations require you to have permission from a crew member to use your terminal while the aircraft is on the ground. To prevent interference with cellular systems, local RF regulations prohibit using your modem while airborne.

## 14.2.6. Children

Do not allow children to play with your GSM terminal. It is not a toy. Children could hurt themselves or others (by poking themselves or others in the eye with the antenna, for example). Children could damage the modem, or make calls that increase your modem bills.

## 14.2.7. Blasting Areas

To avoid interfering with blasting operations, turn your unit OFF when in a « blasting area » or in areas posted: « turn off two-way radio ». Construction crew often use remote control RF devices to set off explosives.

## 14.2.8. Potentially Explosive Atmospheres

Turn your terminal OFF when in any area with a potentially explosive atmosphere. It is rare, but your modem or its accessories could generate sparks. Sparks in such areas could cause an explosion or fire resulting in bodily injuries or even death.

Areas with a potentially explosive atmosphere are often, but not always, clearly marked. They include fuelling areas such as petrol stations; below decks on boats; fuel or chemical transfer or storage facilities; and areas where the air contains chemicals or particles, such as grain, dust, or metal powders.

Do not transport or store flammable gas, liquid, or explosives, in the compartment of your vehicle which contains your terminal or accessories.

Before using your terminal in a vehicle powered by liquefied petroleum gas (such as propane or butane) ensure that the vehicle complies with the relevant fire and safety regulations of the country in which the vehicle is to be used.

## >> 15. Appendix A: Packaging

GL8200 modems come in an outer box that contains two pizza boxes.

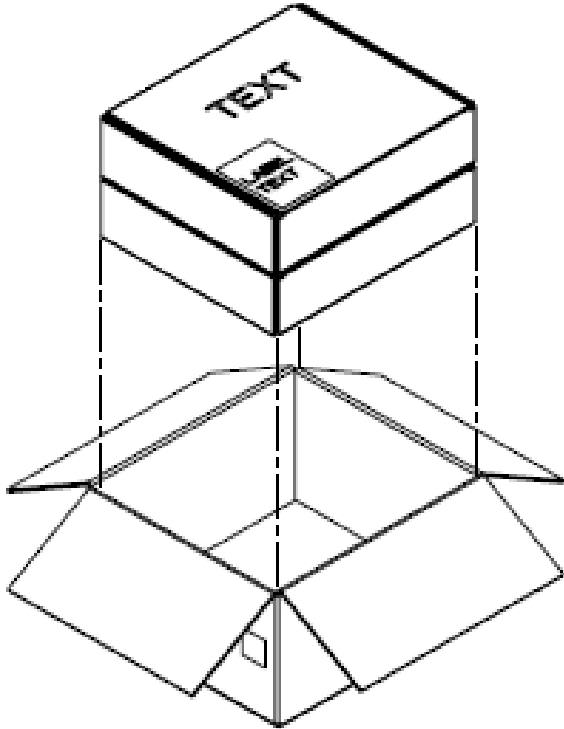

Figure 18. Two Pizza Boxes in an Outer Box

One pizza box contains 50 sets of adaptive cables and DC cables; while the other pizza box is foam-partitioned and contains 50 GL8200 modems.

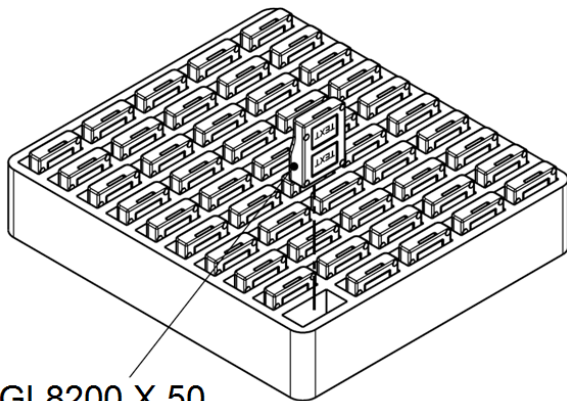

Figure 19. GL8200 in a Pizza Box

## ➤➤ | 16. Appendix B: Product Labeling

Two product labels are available at the back of the GL8200.

### 16.1. Model and MSN Label

The Model and MSN label provides the following information:

- Product name: GL8200
- CE marking with certification number
- Serial number, 2D barcode
- WEEE logo

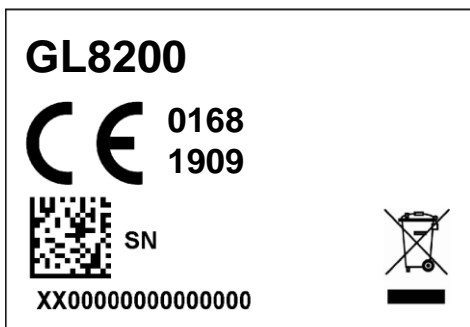

Figure 20. Model and MSN Label

### 16.2. IMEI and Approval Label

The IMEI and Approval label provides the following information:

- IMEI number, 2D barcode
- ICCID number, 2D barcode
- FCC ID
- IC ID
- Company name (Sierra Wireless)
- Operator name

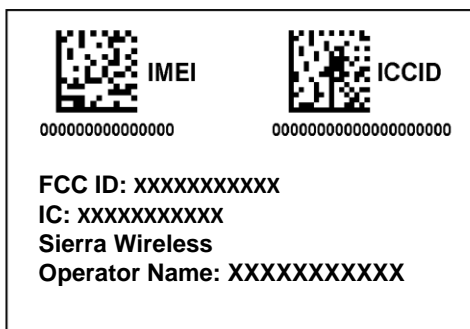

Figure 21. IMEI and Approval Label



**SIERRA**  
WIRELESS®