

Specification for Approval

Product Name: 80W High Bay Driver

G6-080M260A12T (II)

Product Model: G6-080M260T (II)

G6-080V260T (II)

Rev. A.2

Address: Xi Li Song bai Road 1061, Nanshan District, Shenzhen City, Guangdong Province, P.R. China

Post Code: 518108

TEL: 0755-27657000

FAX: 0755-27657908

E-mail: info@mosopower.com

Web site: <http://www.mosopower.com>

Prepared By	Checked By	Approved By

Specification for Approval

Product Name: 80W High Bay Driver

G6-080M260A12T (II)

Product Model: G6-080M260T (II)

G6-080V260T (II)

Rev. A.2

CUSTOMER AUTHORIZED SIGNATURE		
Tested By	Checked By	Approved By
(Company seal) Return one copy to MOSO with approved signature and company seal		

Address: Xi Li Song bai Road 1061, Nanshan District, Shenzhen City, Guangdong Province, P.R. China

Post Code: 518108

TEL: 0755-27657000 FAX: 0755-27657908

E-mail: info@mosopower.com Web site: http://www.mosopower.com

Tested By	Checked By	Approved By

ECN History

A.1	First edition	2023-12-21
A.2	Updated DIP switch diagram and mechanical outline	2024-01-29

Description

G6T-(II) series is specially designed for industrial lighting applications. It is constant current LED driver that operates from 90-305Vac with 0-10V and PWM dimming function. Internal potentiometer and dip switch can adjust power and color temperature. Such round integrated structure enables the driver to have a better heat dissipation, significantly improving reliability and extending product lifetime. To ensure trouble-free operations, protection is provided against input surge, output over voltage, short circuit, and over temperature.



Product Features

- Universal input voltage: 90~305Vac;
- Non-isolated constant current design, Efficiency up to 94%;
- Dip switch adjustable power and color temperature;
- 12V/0.2A auxiliary power supply;
- 3 in 1 dimmable: 0-10Vdc/PWM/Resistor;
- Standby Power Consumption <0.5W;
- Surge protection: DM: 6KV,CM: 6KV;
- Protection: SCP/OVP/OTP;
- Ingress protection rating: IP65;
- Warranty: 5 years.

Application

Suitable for industrial lighting.

Models

Model	Input Voltage (Vac)	MAX Output Power (W)	Output Voltage (Vdc)	Output Current Adjustable Range (A)	Default Current (A)	Eff. (Typ.)	PF(Typ.)	THD(Typ.)
G6-080M260A12T (II)	90~305	80	180~260	0.20~0.37	0.33	94%	0.97	10%
G6-080M260T (II)	90~305	80	180~260	0.20~0.37	0.33	94%	0.97	10%
G6-080V260T (II)	90~305	80	180~260	0.20~0.37	0.33	94%	0.97	10%

Notes:

[1].A12 means with 12V/0.2A auxiliary power supply; V means basic model without dimming; M means with 3-in-1 dimming

[2].All specifications are measured at 25°C ambient temperature, input voltage 230Vac, and the typical value tested at full load, if no specific note.

Optional Model Features

Model	Dim to off 0-10V/PWM /Resistor	1-10V/PWM /Resistor	Adjustable power (single DIP)	Adjustable power/ color temperature (double DIP)	Stepless dimming	Notes
G6-080M260A12T (II)	√	-	optional	optional	optional	Standard: afterglow, Without afterglow (optional)
G6-080M260T (II)	-	√	optional	optional	-	M version default dimming does not turn off
G6-080V260T (II)	-	-	optional	optional	-	V means basic model without dimming

Input Specifications

Parameter	Min.	Typ.	Max.	Notes
Input Voltage Range	90Vac	-	305Vac	
Rated Input Voltage	100Vac	-	277Vac	Refer to Output Power vs. Input Voltage Curve
Input Frequency AC	47Hz	50/60Hz	63Hz	
Max Input Current	-	-	1.0A	120Vac&100% load
Max Input Power	-	-	100W	120Vac&100% load
Leakage	-	-	0.70mA	IEC 60598-1; 240Vac/50Hz
Inrush Current	-	-	100A	220Vac, 100% load
Standby Power Consumption	-	-	0.5W	230Vac, dimming off, no load on auxiliary power supply; (For A12 version)
Power Factor	0.95	0.97	-	230Vac, 50/60Hz, 100% load
	0.90	-	-	120-277Vac, 50/60Hz, 80%-100% load
THD	-	8%	10%	230Vac, 50/60Hz, 100% load
	-	-	20%	120-277Vac, 50/60Hz, 70%-100% load
MCB(B16)	-	17	-	230Vac; 100% load

Output Specifications

Parameter	Min.	Typ.	Max.	Notes
Output Voltage Range	180Vdc	-	260Vdc	
Open Circuit Voltage	-	-	310Vdc	
Output Current Adjustable Range	0.20A	-	0.37A	
Full Power Current Range	0.31A	-	0.37A	216-260Vdc
Dip Switch Adjustable Power		0.33A		Max, 240Vdc, 100% load
		0.27A		Middle, 240Vdc, 80% load
		0.20A		Min, 240Vdc, 60% load
Current Accuracy	-8%	-	+8%	
Total Output Current Ripple (pk-pk)	-	10%	15%	20MHz BW full load& LED load the LED load ripple is slightly different for different LEDs
Startup Overshoot Current	-	-	10%	120-277Vac full load condition, LED load
Auxiliary Source output voltage	10.8V	12V	13.8V	For A12 version
Auxiliary Source output current	-	-	200mA	
Line Regulation	-5%	-	+5%	25°C±10°C ambient temperature, input voltage changes from 120Vac to 277Vac
Load Regulation	-5%	-	+5%	25°C±10°C ambient temperature, 230Vac input, load changes from 70% to 100%
Turn-on Delay Time	-	-	1.0s	120-277Vac, 100% load

General Specification

Parameter	Min.	Typ.	Max.	Notes
Efficiency @120Vac	91%	92%	-	0.33A, 240Vdc; 25°C ambient temperature, no load of auxiliary source
Efficiency @230Vac	92%	94%	-	0.33A, 240Vdc; 25°C ambient temperature, no load of auxiliary source
Efficiency @277Vac	92%	94%	-	0.33A, 240Vdc; 25°C ambient temperature, no load of auxiliary source
MTBF	-	200Khours	-	25°C±10 ambient temperature, 230Vac, 80% load (MIL-HDBK-217/SR-332)
Lifetime	-	50Khours	-	230Vac&100% load, Tc 75°C, refer to lifetime vs. case temperature curve
Operating Temperature Ta	-40°C	-	+50°C	
Operating Case Temperature for Safety Tc_s	-40°C	-	+90°C	
Operating Case Temperature for Warranty Tc_w	-40°C	-	+75°C	5 years warranty shell temperature Humidity: 10%-90% RH
Storage Temperature Ta	-40°C	-	+85°C	Humidity: 5%-95% RH
Altitude	-60m	-	4000m	
Over Temperature Protection Tc	90°C	95°C	100°C	Decreases output current, returning to normal after over temperature is removed
Short Circuit Protection	-	-	15W	Constant current mode. The output shall return to normal when the fault condition is removed.
Output Over Voltage Protection	-	-	5W	When the output voltage of the product exceeds the limit range, it will enter the protection state. When the fault is removed, the product will automatically return to normal.
Dimensions (Φ*H)mm	Φ127*H59			
Net Weight	570±50g/PCS			
Package (L*W*H)	490*370*169 mm; 10PCS/Ctn., GW: 7Kg			

Dimming

Parameter	Min.	Typ.	Max.	Notes
Absolute Maximum Voltage	-	10V	15V	On the Vdim (+) Pin
Source Current on Vdim (+)Pin	-	100uA	200uA	
Dimming Range	10% I _{o max}	-	100% I _{set}	I _{set} =0.20-0.37A
Suggest Dimming Input 0-10V	0V	-	10V	
Turn-on voltage	0.8V	-	1.1V	For A12 version
Turn-off voltage	0.6V	-	0.9V	
PWM in High Level	9.7V	-	10.3V	
PWM in Low Level	0V	-	0.3V	
PWM in Frequency Range	1KHz	-	2KHz	
PWM in Duty Cycle	1%	-	99%	
Turn-on duty cycle	8%	-	11%	For A12 version
Turn-off duty cycle	6%	-	9%	
Resistor Range	0	-	100KΩ	

Safety Specifications

Parameter	UL	TUV	Note
Dielectric Strength (Input-Ground)	1600Vac	1500Vac	60s, Current not exceeding 5mA input L/N short-circuit
Grounding Resistance	≤0.1Ω		UL:25°C±10°C Ambient Temperature, pass 30A Current, 120s. TUV:25°C±10°C Ambient Temperature, pass 25A Current, 60s.
Insulation Resistance	≥10MΩ		Input-PE, 500Vdc/60s/25°C

Notes: The voltage resistance requirement of aluminum substrate is greater than 2KVac.

Safety Compliance

Safety Category	Safety normative standards	Certification	Notes
CCC	GB19510.1, GB19510.14	√	
CE	EN61347-1, EN61347-2-13, EN62493	√	
ENEC	EN61347-1, EN61347-2-13, EN62384	√	
CB	IEC61347-1, IEC61347-2-13	√	
BIS	IS 15885(PART 2/SEC 13)		
UL	UL 8750	√	
CUL	CSA C22.2 No.250.13	√	
KC	K61347-1, K61347-2-13		
PSE	J61347-1, J61347-2-13		
SAA	AS/NZS IEC 61347.2.13	√	
SAA	AS/NZS 61347.1	√	

EMC Compliance

EMC Category	Standards	Approved	Notes
CCC	GB/T 17743, GB 17625.1	√	
CE	EN 55015	√	
CE	EN 61000-3-2, EN 61000-3-3	√	
CE	EN61000-4-2,3,4,5,6,11	√	
CE	EN 61547	√	
KC	K61547		
KC	K00015		
PSE	J55015		
FCC	FCC part 15	√	Class B
Surge Shock Immunity	ANSI/C82.77-5-2017		
	IEC/EN 61000-4-5	√	
Ringing Wave	IEC/EN 61000-4-12		
	ANSI/IEEE C62.41.2		

RoHS

Our products comply with reference to RoHS Directive (EU) 2015/863 amending 2011/65/EU.

Inrush Current Waveform

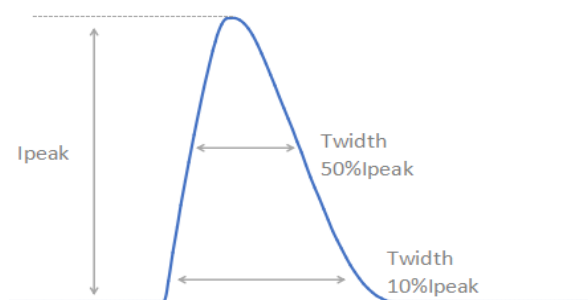

V_{in}	I_{peak}	$T(@10\% \text{ of } I_{peak})$	$T(@50\% \text{ of } I_{peak})$
220Vac	75A	-	108 μ s

Output Voltage vs. Output Current

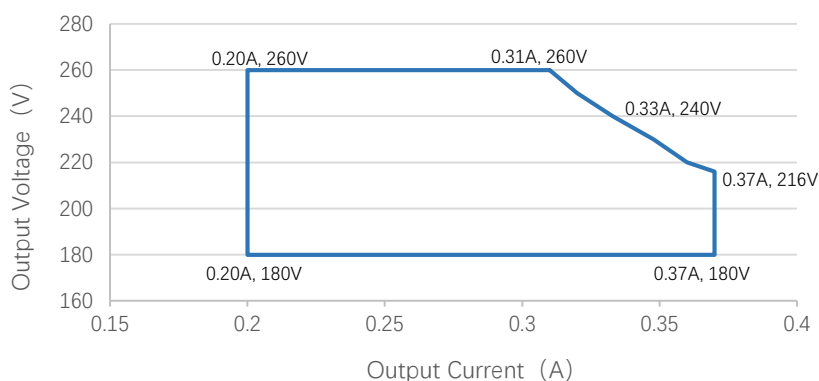

Output Power vs. Input Voltage

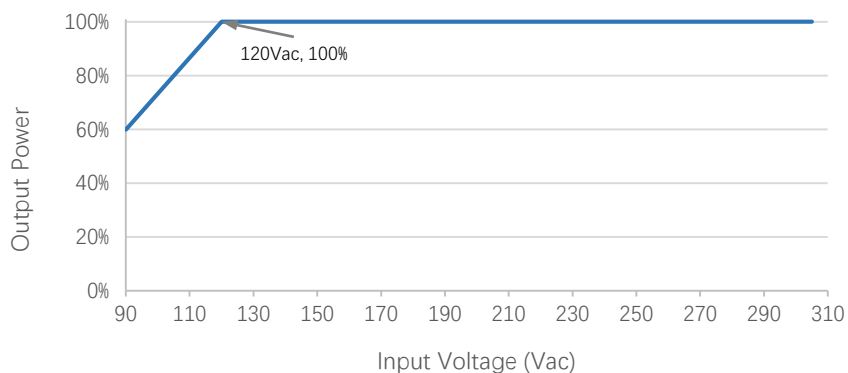

Efficiency vs. Load

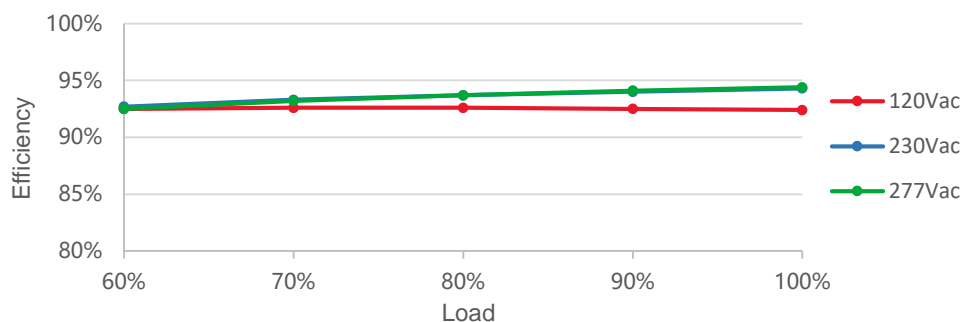

PF vs. Load

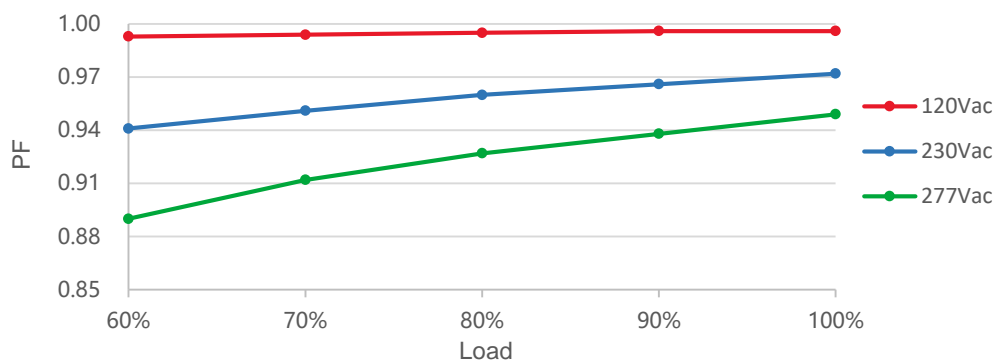

THD vs. Load

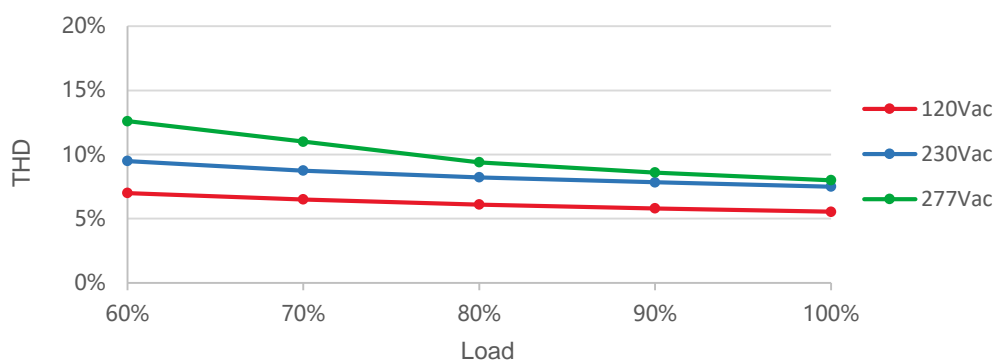

Output Power vs. Case Temperature

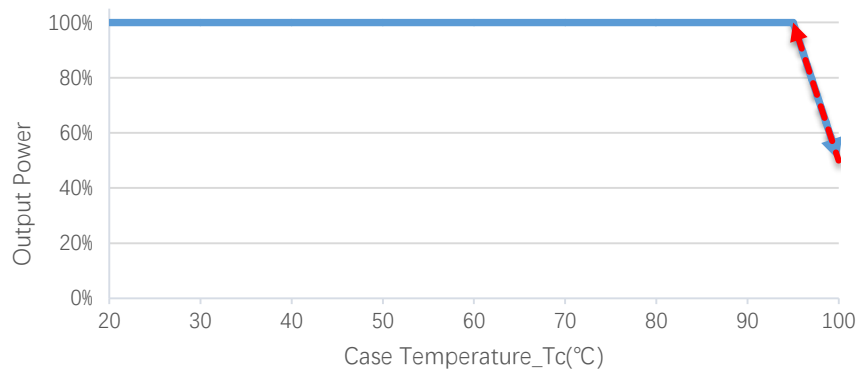

Lifetime vs. Case Temperature

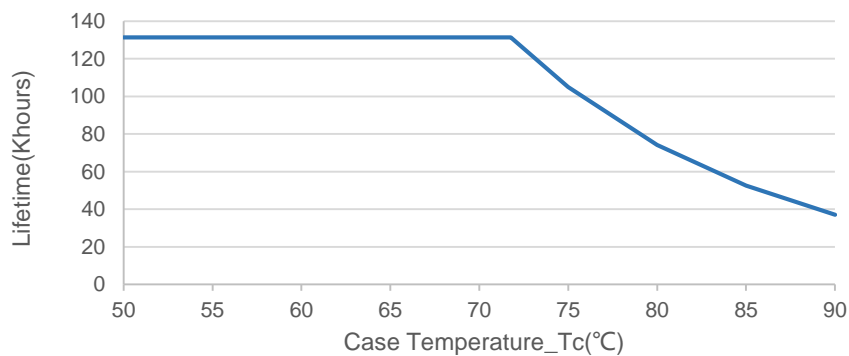

0-10V/PWM/ Resistor Dimming

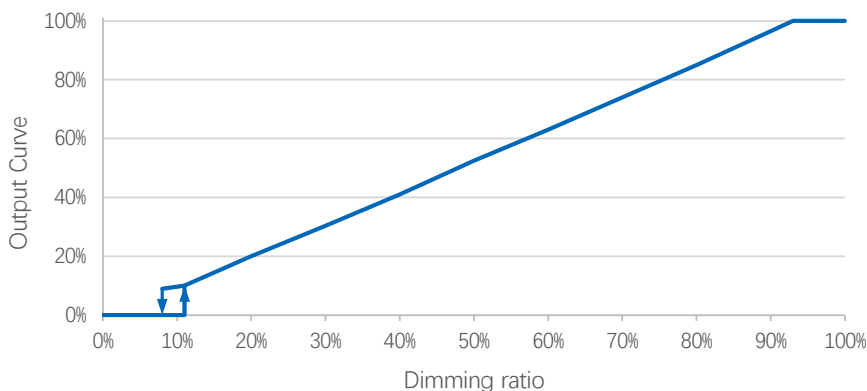

Notes: A12 version default dim to off.

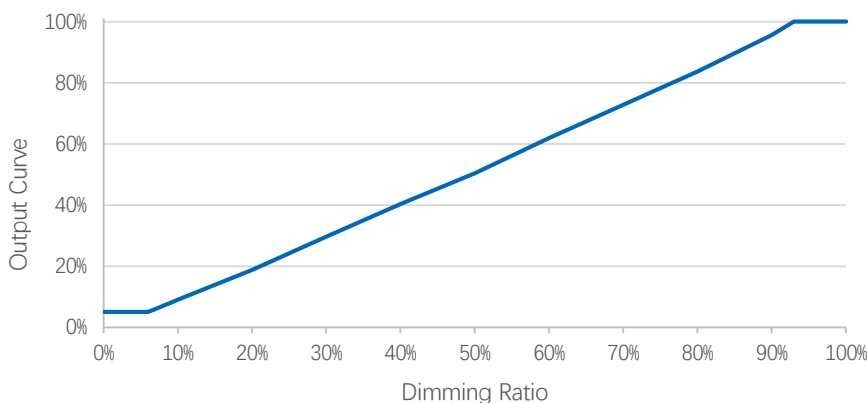

Notes: M version default dimming does not turn off.

Dip Switch Diagram

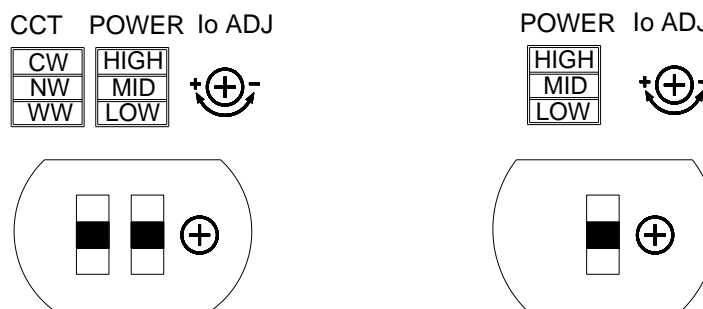

Function	Description		
Color Temperature	Cool colors(CW)	Mixed colors(NW)	Warm colors(WW)
Power	HIGH (100%) : 0.33A(80W)	MID (80%) : 0.27A(64W)	LOW (60%) : 0.20A(48W)

Notes: Using the dip switch when adjusting the color temperature or power, please operate it after the input is powered off.

Mechanical Outline

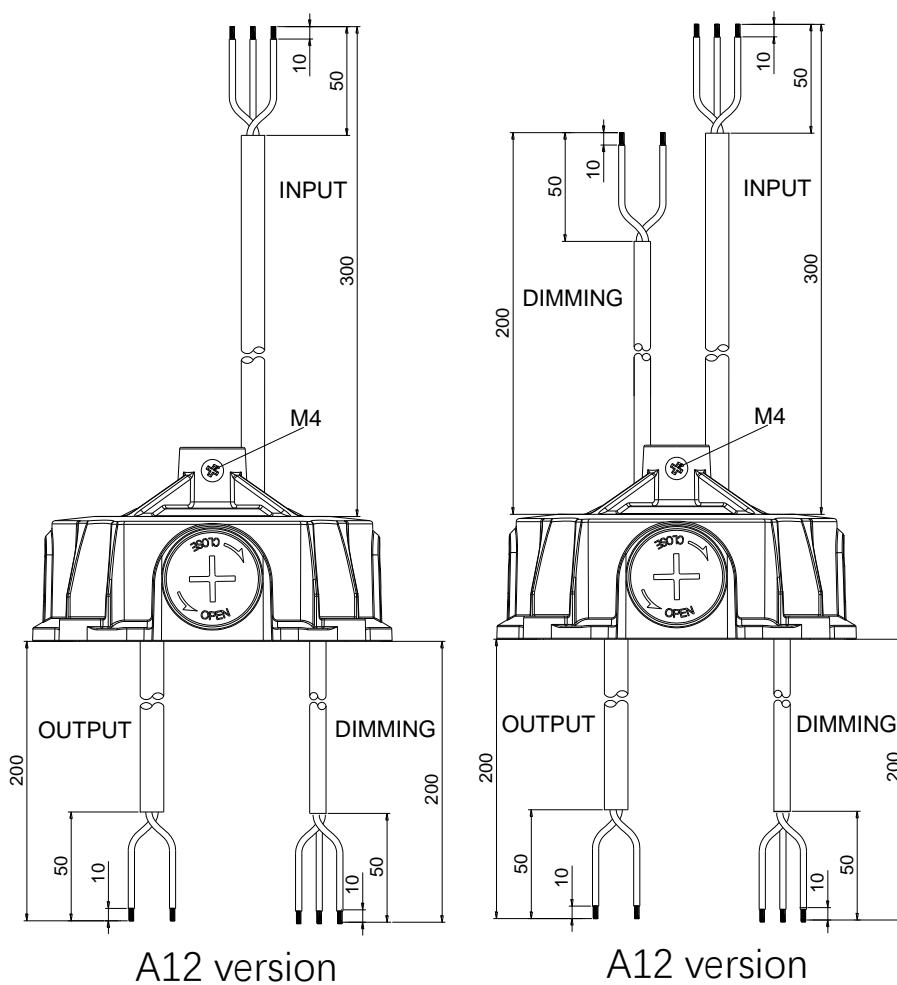
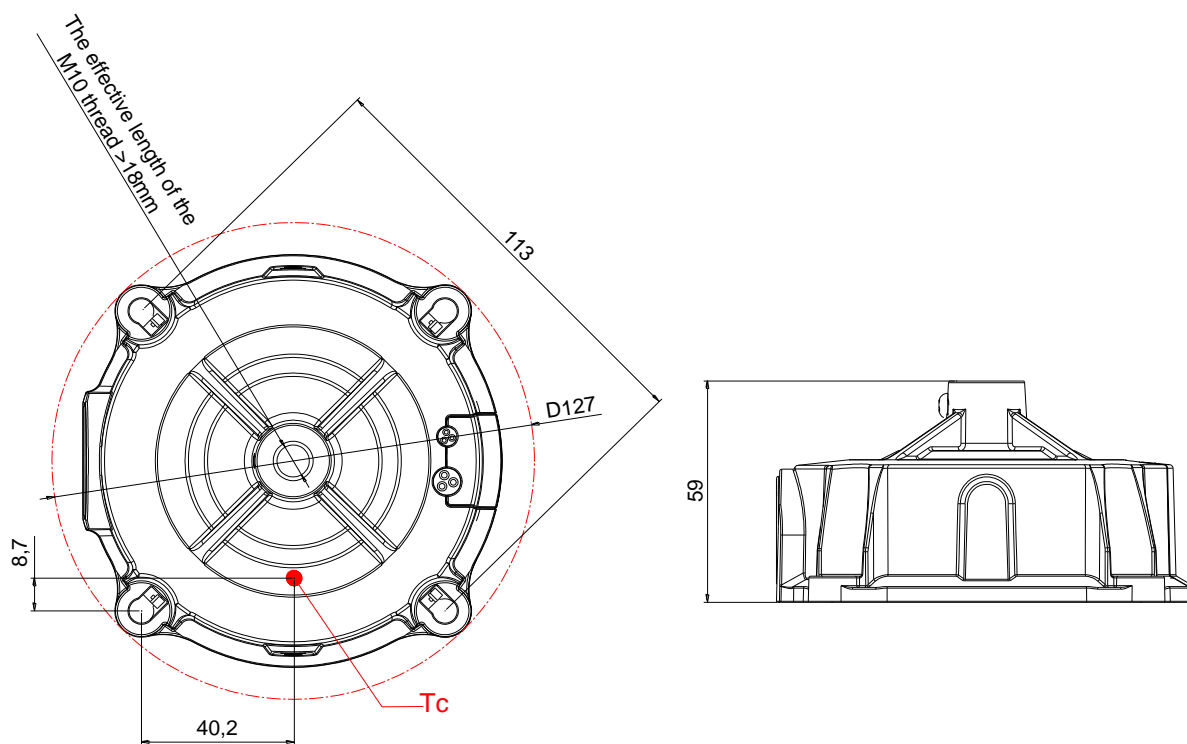

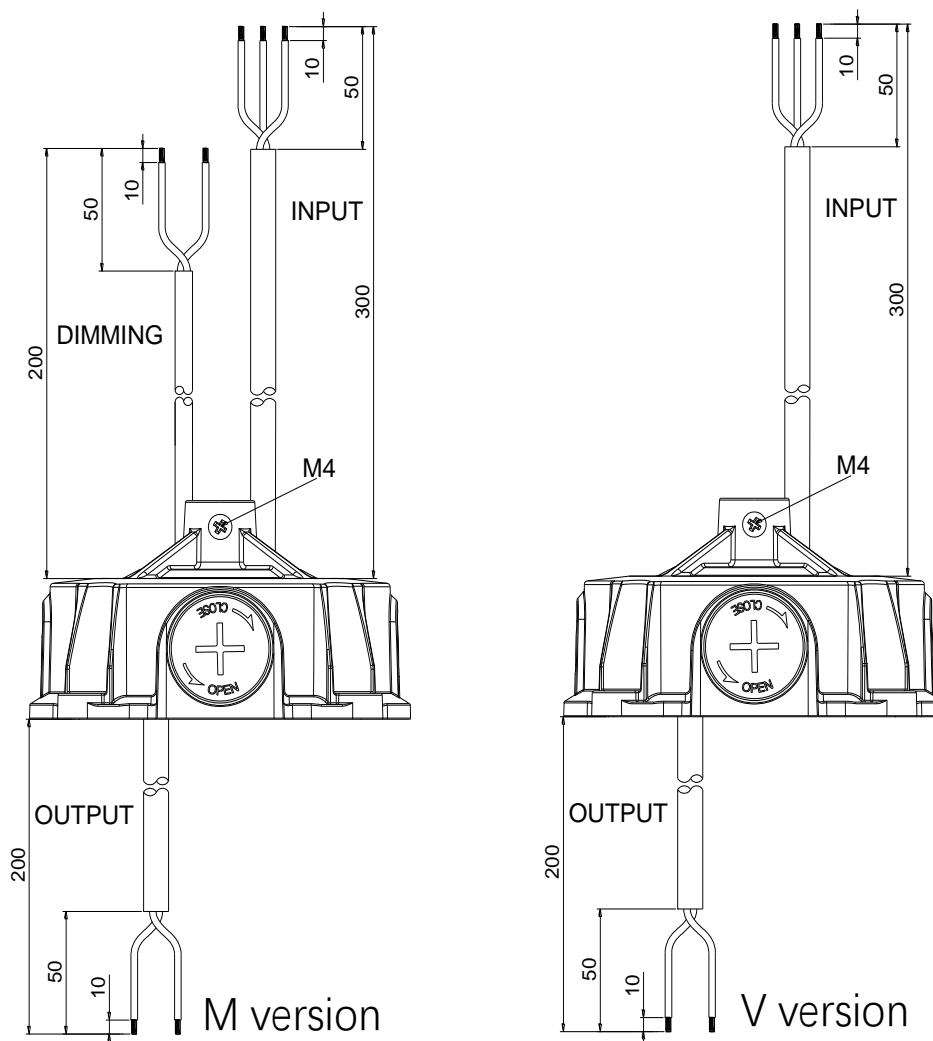

Specifications

Input	CCC+VDE H05RN-F 3*1.0 mm ² Outside Diameter: 7.2mm L=300±20mm Strip 50±3mm, Tinning 10±1mm; L: brown, N: blue, G: yellow/green	CCC/CE
	UL SJTW 18AWG+3C Outside Diameter: 7.8mm L=300±20mm, Strip 50±3mm Tinning 10±1mm; L: black, N: white, G: green	UL
Output	CCC+VDE H05RN-F 2x1.0mm ² Outside Diameter: 6.8mm L=200±20mm Strip 50±3mm, Tinning 10±1mm; LED+: brown, LED-: blue	CCC/CE
	CCC+VDE H05RN-F 3x1.0mm ² Outside Diameter: 7.8mm L=200±20mm Strip 50±3mm, Tinning 10±1mm; LED+: brown, LED1-: blue, LED2-: black	CCC/CE (double DIP)
	UL SJTW 18AWG+2C Outside Diameter: 7.8mm L=200±20mm, Strip 50±3mm, Tinning 10±1mm; LED+: red, LED-: black	UL
	UL SJTW 18AWG+3C Outside Diameter: 7.8mm L=200±20mm, Strip 50±3mm, Tinning 10±1mm; LED+: red, LED1-: black, LED2-: pink	UL(double DIP)
Dimming	UL 2733 22AWG+2C Outside Diameter: 5.45mm L=200±20mm, Strip 50±3mm, Tinning 10±1mm; DIM+: purple, DIM-: pink	M version
	UL 21996 22AWG+3C Outside Diameter: 5.0mm L=200±20mm, Strip 50±3mm, Tinning 10±1mm; DIM+: purple, DIM-: pink/12V-, black and white: 12V+	A12 version