





SPECIFICATION FOR APPROVAL

DESCRIPTION : SMD Inductor
 SPECIFICATION : PIST-332K 3.3MH
 PART NO. : FWSMDPI-332K
 ISSUE DATE : 18 September 2015

MANUFACTURER APPROVAL		
PREPARED	CHECKED	APPROVED
 <p>工程部 2015.09.18 夏晓凯</p>	 <p>工程部 2015.09.18 朱衍</p>	 <p>工程部 2015.09.18 潘玉财</p>

CUSTOMER APPROVAL		
RECEIPT	CHECKED	APPROVED

Haining Ferriwo Electronics Co., Ltd.	
Address: 4/F, Kechuang Mansion, 128 Shuanglian Rd., Haining Economic Development Zone, Haining, Zhejiang 314400, China	
TEL: +86-573-87088701	FAX: +86+573-87081130
www.ferriwo.com	sales@ferriwo.com

SPECIFICATION

1. PHYSICAL DIMENSION(UNIT: m/m):

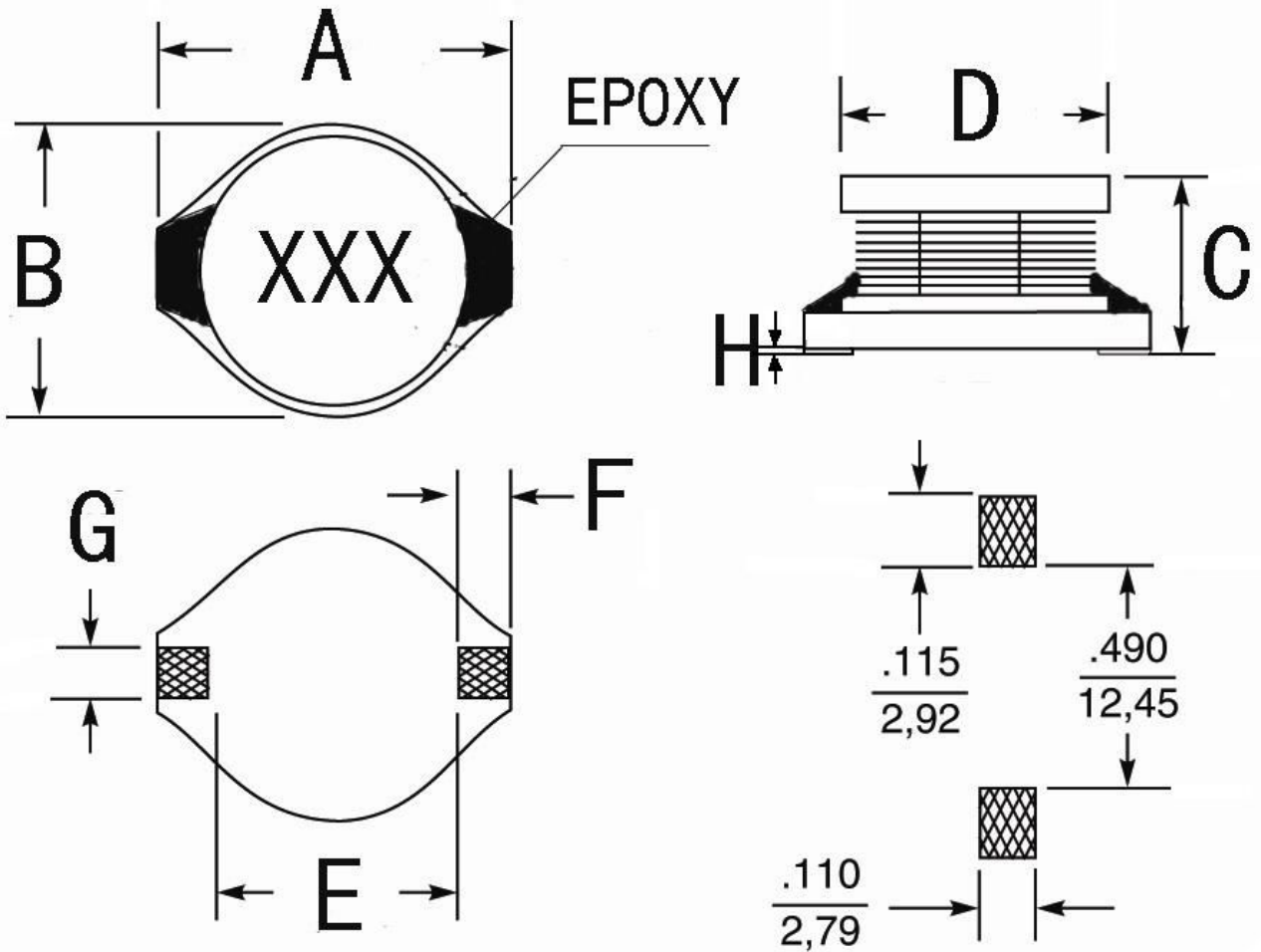

- ※DIMENSIONS WITHOUT TOLERANCE ARE APPROX
- ※DIMENSION DOES NOT INCLUDE SOLDER USED ONCOILS

LEAD FREE

DIM	A	B	C	D	E	F	G	H				
	+/-0.5	MAX	MAX	REF	+/-0.25	REF	REF	+/-0.05				
SPEC	18.03	15.5	12	12.5	12.95	2.54	2.54	0.15				

	DESCRIPTION	SMD INDUCTOR
	Customer P/N	PIST-332K 3.30MH
	FERRIWO P/N	FWSMDPI-332K

SPEC. NO.	PS-2001-006	PREPARED		APPROVED	
-----------	-------------	----------	--	----------	--

2.WINDING TABLE:

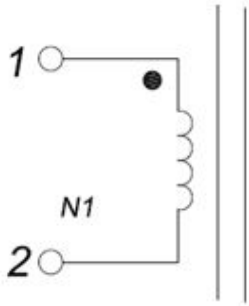

3.GENERAL SPECIFICATION:

PeakTemp:260°C max

Max time above230° C:50secmax

Max time above200° C:70secmax

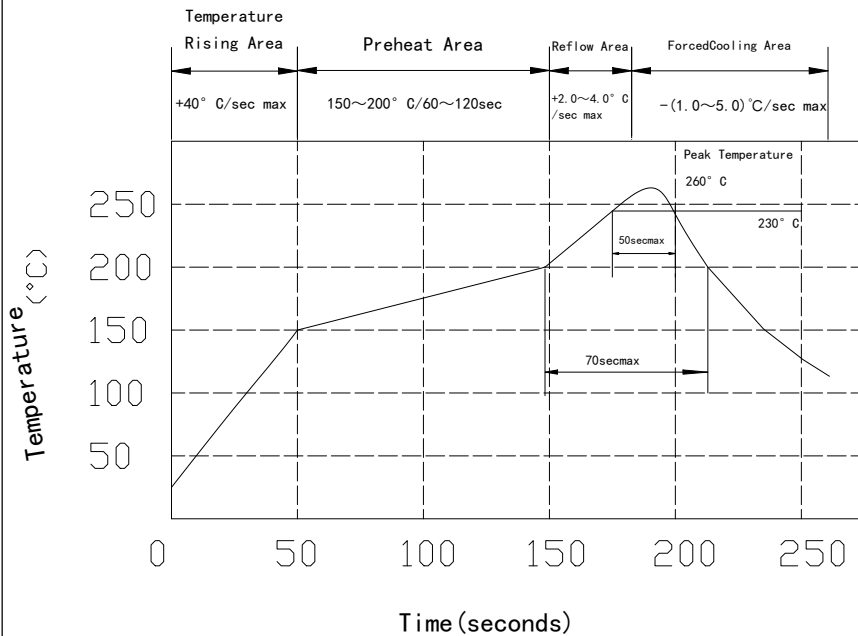

1. Tested at 100KHz,0.1Vrms,0 Adc.
2. DC current at which the inductance drops 10%max from its value without current.
- 3.Average current for 40°C temperature rise from 25°C.
- 4.Electrical specifications at:25°C
- 5.Storage temp range:-40°C----+125°C
- 6.Operating temp range:-40°C----+85°C

LEAD FREE

	DESCRIPTION	SMD INDUCTOR			
	Customer P/N	PIST-332K 3.30MH			
	FERRIWO P/N	FWSMDPI-332K			
SPEC. NO.	PS-2001-006	PREPARED		APPROVED	

SPECIFICATION

4. ELECTRONICAL CHARACTERISTIC:

TEST CONDITION : TEMPERATURE AT 25°C

HUMIDITY AT 65 ±5% RH

TEST ITEM	TEST CONDITION	RESULT
INDUCTANCE CH-3250	@1.0KHz,0.25V (1~2)	3.3mH±20%
D.C.R CH-502	(1~2)	4.0 Ω MAX
IDC CH-3250	(1~2)	1.0A MAX

LEAD FREE



DESCRIPTION

SMD INDUCTOR

Customer P/N

PIST-332K 3.30MH

FERRIWO P/N

FWSMDPI-332K

SPEC. NO.

PS-2001-006

PREPARED



APPROVED



5. PACKAGE:

Packaging Information

Reel Dimension Tape Dimension

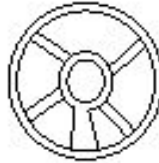
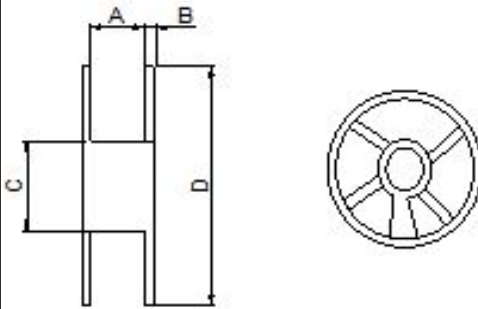

STYLE	A(mm)	B(mm)	C(mm)	D(mm)
13"×32	32.5	2.3±0.1	100	330

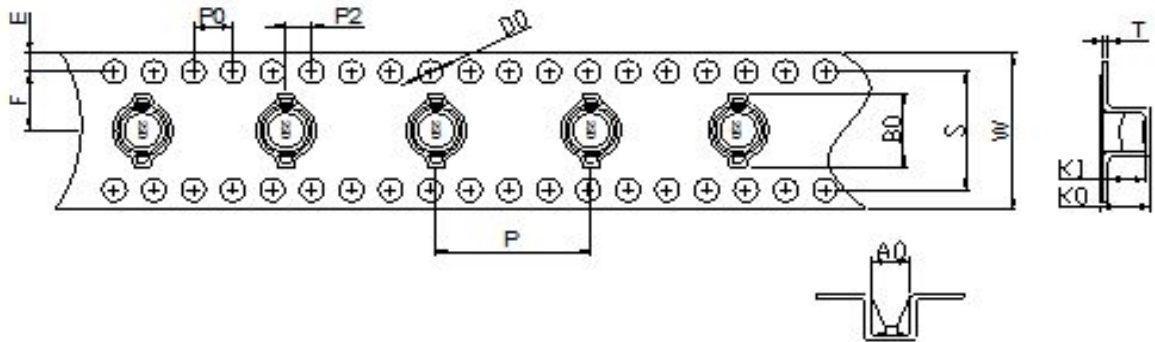

STYLE	W	E	F	P	P0	P2	D0
32mm	32.0±0.3	1.75±0.1	14.2±0.1	20.0±0.1	4.0±0.1	2.0±0.1	1.5±0.1
	T	A0	B0	K0	K1	S	
	0.40±0.05	15.4±0.1	18.8±0.1	7.5±0.1	7.3±0.1	28.4±0.1	

Packaging Quantity

SERIES	1 REEL	INNER CARTON			MIDDLE CARTON			OUTER CARTON		
	QTY(PCS)	REEL	QTY(PCS)	SIZE(cm)	REEL	QTY(PCS)	SIZE(cm)	REEL	QTY(PCS)	SIZE(cm)
SFP5022F	250	2	500	345×340×70				4	1000	360×350×156

Tearing off Force

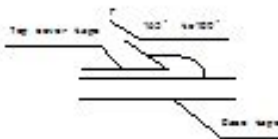

The force for tearing off cover tape is 5 to 120 grams in the arrow direction under the following conditions

Room Temp (°C)	Room Humidity (%)	Room aim (hpa)	Room Speed mm/min
5-35	45-85	860-1060	300

LEAD FREE

FERRIWO

DESCRIPTION	SMD INDUCTOR
Customer P/N	PIST-332K 3.30MH
FERRIWO P/N	FWSMDPI-332K

SPEC. NO.

PS-2001-006

PREPARED



APPROVED

