

SPECIFICATION

1. PHYSICAL DIMENSION(UNIT: m/m):

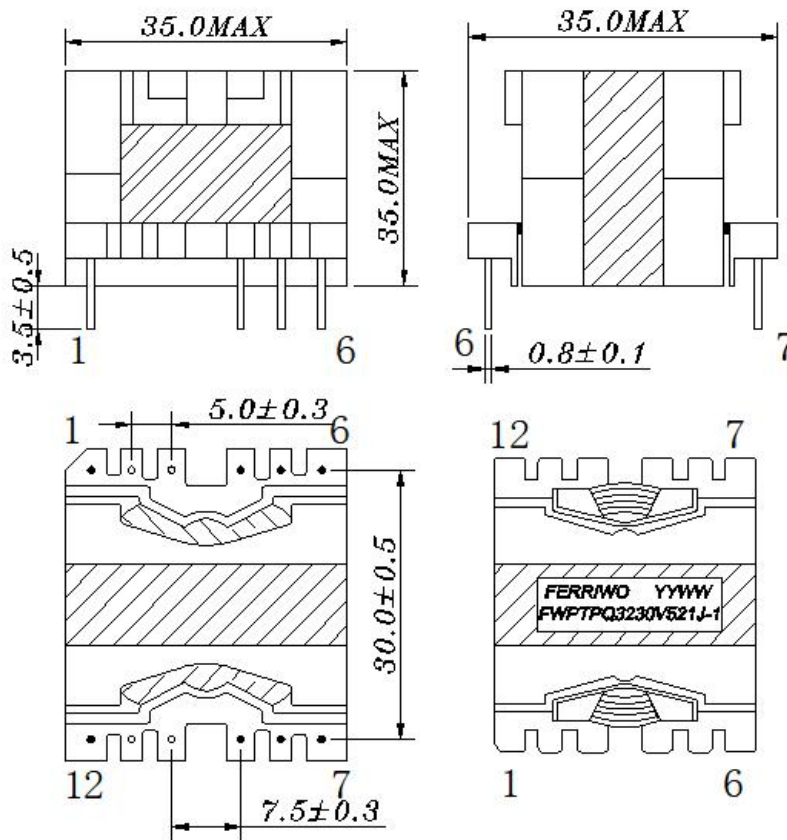



NOTE: Pin2,3,10,11 cut off

*.Core fix tape 3Ts .

*.The Label is placed on the product(see the picture above).

LEAD FREE

DIM	A	B	C	D	E	F	G	H				
SPEC												
						DESCRIPTION			CHOKE			
						Customer P/N			PQ1000			
						FERRIWO P/N			FWPTPQ3230V521J-1			
SPEC. NO.	PS-2023-021				PREPARED			APPROVED				

SPECIFICATION

2.WINDING TABLE:

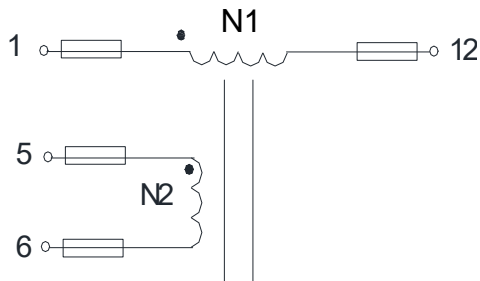

3.WINDING:

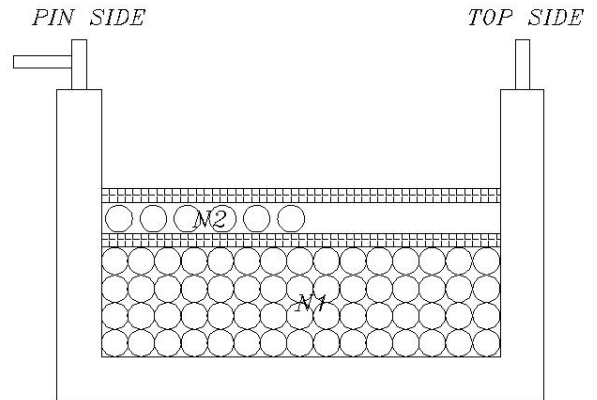

4.WINDING TABLE:

Winding NO.	Margin Tape	PIN	Wire & Wire Copper	Turns	Winding Type	Tape Layer	Tube
N1		1~12	USTC-0.07 ϕ x 80P	66.5Ts	CLOSE	2Ts	S=F:20mm
N2		5~6	USTC-0.08 ϕ x 20P	5Ts	SPREAD	2Ts	S=F:18mm

NOTE:

- 1. Products should be vacuum impregnation
- *VARNISH RATIO: 1:1
- *VACUUM TIME: 15~20minutes
- *BAKED TEMPERATURE : 120°C±10°C, 1~1.5hours

LEAD FREE

	DESCRIPTION	CHOKE			
	Customer P/N	PQ1000			
	FERRIWO P/N	FWPTPQ3230V521J-1			
SPEC. NO.	PS-2023-021	PREPARED		APPROVED	

SPECIFICATION

5. ELECTRONICAL CHARACTERISTIC:

TEST CONDITION : TEMPERATURE AT 25°C

HUMIDITY AT 65 ±5% RH

TEST ITEM	TEST CONDITION	RESULT
INDUCTANCE CH-3250	@1KHz,0.3V (1~12)	520uH±5%

LEAD FREE

DESCRIPTION

CHOKE

Customer P/N

PQ1000

FERRIWO P/N

FWPTPQ3230V521J-1

SPEC. NO.

PS-2023-021

PREPARED



APPROVED



SPECIFICATION

6. MATERIAL LIST :

ITEM	MATERIAL	SUPPLIER OR MANUFACTURER	TEMPRATING	
1	CORE PQ3230	FW95 OR EQUIVALENT	HAINING FERRIWO ELECTRONICS CO., LTD.	
2	BOBBIN FWB3220-Y	PHENOLIC OR EQUIVALENT	SUMITOMO BAKELITE CO., LTD. UL NO E41429	150°C
3	WIRE	2UEW-F	PACIFIC ELECTRIC WIRE&CABLE(SHENZHEN) CO. LTD UL NO E84081	155°C
4	TAPE	CT280	YAHUA STICKING TAPE CO.,LTD UL NO E165111	130°C
5	VARNISH	R-1038	JOHN C DOLPH CO BC-346A UL NO E317427	130°C
6	FLUX	TF9100	LINAN GUITONG CHEMICAL TECHNICAL CO.,LTD	
7	TIN	Sn99.3Cu0.7	HAINING ZHUCHANG METAL FOIL CO;LTD	

LEAD FREE



DESCRIPTION

CHOKE

Customer P/N

PQ1000

FERRIWO P/N

FWPTPQ3230V521J-1

SPEC. NO.

PS-2023-021

PREPARED



APPROVED

