





**SPECIFICATION FOR APPROVAL**

DESCRIPTION : \_\_\_\_\_ Transformer \_\_\_\_\_  
 SPECIFICATION : \_\_\_\_\_ EFD30-085-700 \_\_\_\_\_  
 PART NO. : \_\_\_\_\_ FWPTEFD31H461J \_\_\_\_\_  
 ISSUE DATE : \_\_\_\_\_ June 2, 2023 \_\_\_\_\_

<b>MANUFACTURER APPROVAL</b>		
<b>PREPARED</b>	<b>CHECKED</b>	<b>APPROVED</b>
		

<b>CUSTOMER APPROVAL</b>		
<b>RECEIPT</b>	<b>CHECKED</b>	<b>APPROVED</b>

<b>Haining Ferriwo Electronics Co., Ltd.</b>	
Address: Block 13, Caohejing Technology Park, No.8, Haining Avenue, Haining, Zhejiang, China	
TEL: +86-573-87088701	FAX: +86+573-87081130
www.ferriwo.com	sales@ferriwo.com



# SPECIFICATION

## 1. PHYSICAL DIMENSION(UNIT: m/m):

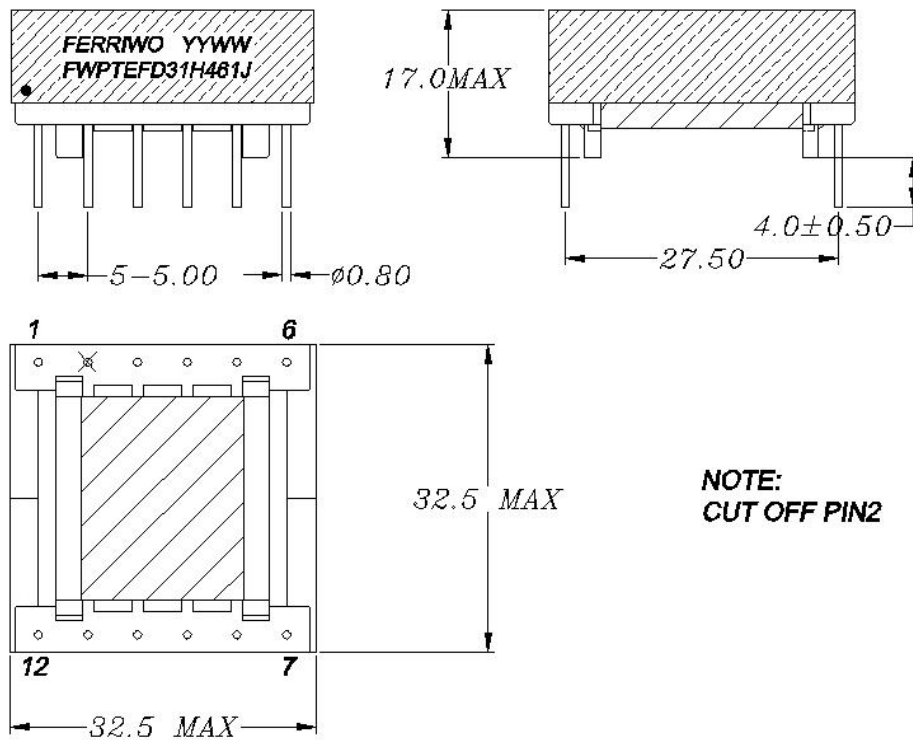

**NOTE:  
CUT OFF PIN2**

**LEAD FREE**

- \*.Core fix tape 2Ts tape .
- \*.The Label is placed on the product(see the picture above).
- \*.Marked the **PIN #1** by black dot!

DIM	A	B	C	D	E	F	G	H				
SPEC												
						DESCRIPTION		TRANSFORMER				
						Customer P/N		EFD30-085-700				
						FERRIWO P/N		FWPTEFD25H461J				
SPEC. NO.	PS-2023-034				PREPARED			APPROVED				

# SPECIFICATION

## 2. SCHEMATIC DIAGRAM:

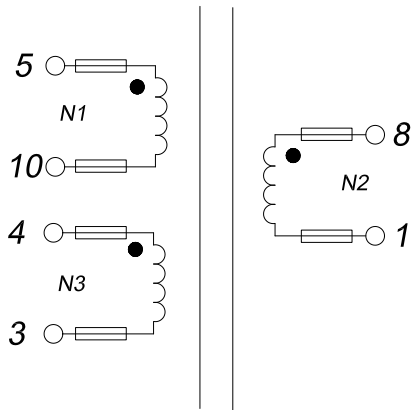

## 3. CROSS SECTION:

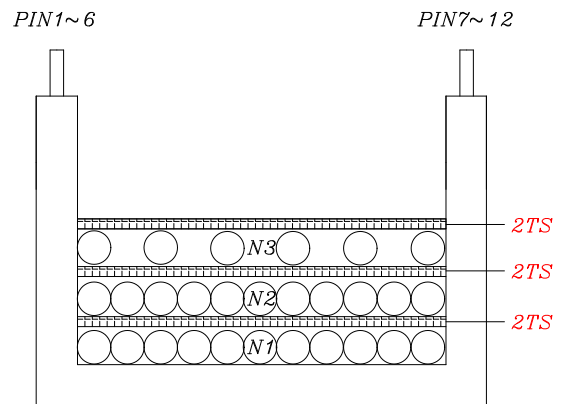

## 4. WINDING TABLE:

Winding NO.	Margin Tape	PIN	Wire & Wire Copper	Turns	Winding Type	Tape Layer	Tube
N1		5-10	0.35 $\phi$ x1P	48Ts	CLOSE	2Ts	S=F:10mm
N2		8-1	0.35 $\phi$ x2P	24Ts	CLOSE	2Ts	S=F:10mm
N3		4-3	0.35 $\phi$ x1P	6Ts	SPREAD	2Ts	S=F:10mm

### NOTE:

1. Products should be vacuum varnish.

\*VARNISH RATIO:1:2

\*VACUUM TIME:15~20minutes

\*BAKED TEMPERATURE:120°C±10°C, 1~1.5huors

**LEAD FREE**

**FERRIWO**

DESCRIPTION

TRANSFORMER

Customer P/N

EFD30-085-700

FERRIWO P/N

FWPTEFD25H461J

SPEC. NO.

PS-2023-034

PREPARED



APPROVED



# SPECIFICATION

## 5. ELECTRONICAL CHARACTERISTIC:

TEST CONDITION : TEMPERATURE AT 25°C  
HUMIDITY AT 65 ±5% RH

TEST ITEM	TEST CONDITION	RESULT
INDUCTANCE CH-3250	@1KHz,0.3V (5~10)	461uH±5%
LEAKAGE INDUCTANCE CH-3250	@1KHz,0.3V (5~10)	15.0μH MAX SHORT PIN 1,8
HI-POT TEST CH-9052	@ 2mA 3SEC (AC)	N1,N3<->N2 3.0 KV; N1<->N3 1.5 KV;

NOMINAL RATED POWER - 40 VA

**LEAD FREE**



DESCRIPTION	TRANSFORMER
Customer P/N	EFD30-085-700
FERRIWO P/N	FWPTEFD25H461J

SPEC. NO.	PS-2023-034	PREPARED		APPROVED	
-----------	-------------	----------	--	----------	--

# SPECIFICATION

5/5

## 6. MATERIAL LIST :

ITEM		MATERIAL	SUPPLIER OR MANUFACTURER	TEMPRATING
1	CORE EFD31/30/9	FW95 OR EQUIVALENT	HAINING FERRIWO ELECTRONICS CO., LTD.	
2	BOBBIN EFD30 (6+6)	PHENOLIC OR EQUIVALENT	CHANG CHUN PLASTICS CO., LTD. UL NO E59481	150°C
3	WIRE	2UEW-F	PACIFIC ELECTRIC WIRE&CABLE(SHENZHEN) CO. LTD UL NO E84081	155°C
4	TAPE	CT280	YAHUA STICKING TAPE CO.,LTD UL NO E165111	130°C
5	VARNISH	BC-346A	JOHN C DOLPH CO BC-346A UL NO E317427	130°C
6	TUBE	TEFLON TUBE	GREAT HOLDING INDUSTRIAL CO.,LTD UL NO E156256	200°C
7	FLUX	TF9100	LINAN GUITONG CHEMICAL TECHNICAL CO.,LTD	
8	TIN	Sn99.3Cu0.7	HAINING ZHUCHANG METAL FOIL CO;LTD	

**LEAD FREE**



DESCRIPTION

TRANSFORMER

Customer P/N

EFD30-085-700

FERRIWO P/N

FWPTEFD25H461J

SPEC. NO.

PS-2023-034

PREPARED



APPROVED

