





SPECIFICATION FOR APPROVAL

DESCRIPTION : Transformer
 SPECIFICATION : EFD30-150-350
 PART NO. : FWPTEFD31H441J
 ISSUE DATE : June 2, 2023

MANUFACTURER APPROVAL		
PREPARED	CHECKED	APPROVED
		

CUSTOMER APPROVAL		
RECEIPT	CHECKED	APPROVED

Haining Ferriwo Electronics Co., Ltd.	
Address: Block 13, Caohejing Technology Park, No.8, Haining Avenue, Haining, Zhejiang , China	
TEL: +86-573-87088701	FAX: +86+573-87081130
www.ferriwo.com	sales@ferriwo.com

SPECIFICATION

1. PHYSICAL DIMENSION(UNIT: m/m):

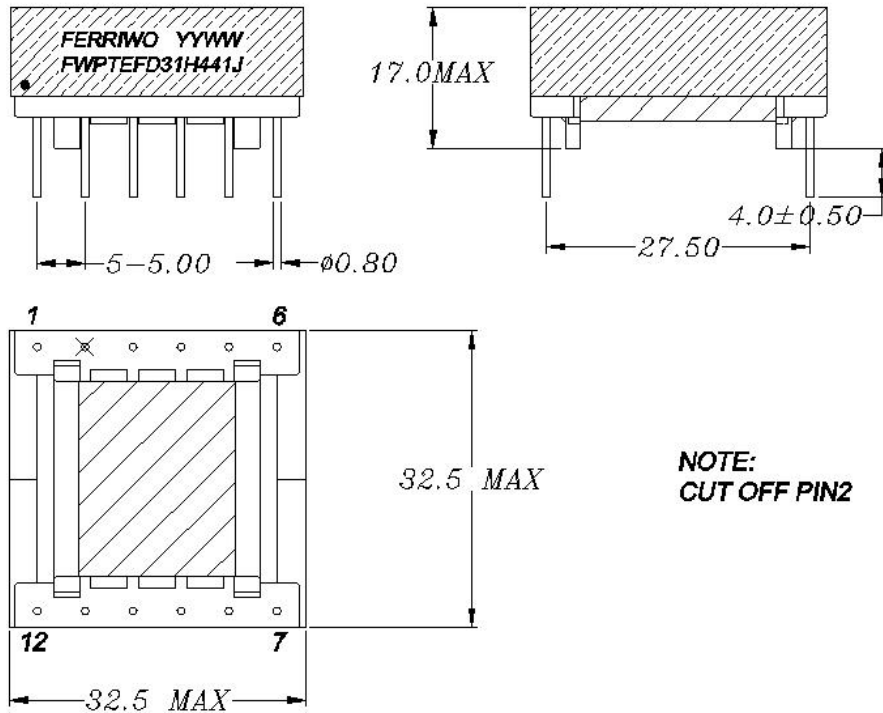

LEAD FREE

- *.Core fix tape 2Ts tape .
- *.The Label is placed on the product(see the picture above).
- *.Marked the **PIN #1** by black dot!

DIM	A	B	C	D	E	F	G	H				
SPEC												
						DESCRIPTION		TRANSFORMER				
						Customer P/N		EFD30-150-350				
						FERRIWO P/N		FWPTEFD25H441J				
SPEC. NO.	PS-2023-035				PREPARED			APPROVED				

SPECIFICATION

2. SCHEMATIC DIAGRAM:

3. CROSS SECTION:

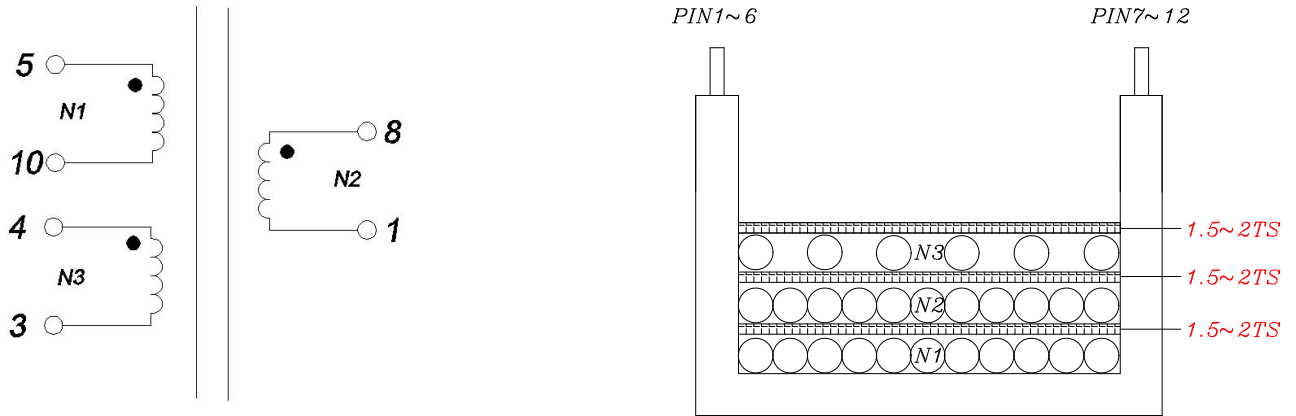

4. WINDING TABLE:

Winding NO.	Margin Tape	PIN	Wire & Wire Copper	Turns	Winding Type	Tape Layer	Tube
N1		5-10	0.35 ϕ x1P	47Ts	CLOSE	1.5~2Ts	
N2		8-1	0.31 ϕ x1P	47Ts	CLOSE	1.5~2Ts	
N3		4-3	0.31 ϕ x1P	6Ts	SPREAD	1.5~2Ts	

NOTE:

- 1. Products should be vacuum varnish.
- *VARNISH RATIO:1:2
- *VACUUM TIME:15~20minutes
- *BAKED TEMPERATURE:120°C±10°C, 1~1.5huors

LEAD FREE

	DESCRIPTION	TRANSFORMER			
	Customer P/N	EFD30-150-350			
	FERRIWO P/N	FWPTEFD25H441J			
SPEC. NO.	PS-2023-035	PREPARED		APPROVED	

SPECIFICATION

5. ELECTRONICAL CHARACTERISTIC:

TEST CONDITION : TEMPERATURE AT 25°C
HUMIDITY AT 65 ±5% RH

TEST ITEM	TEST CONDITION	RESULT
INDUCTANCE CH-3250	@1KHz,0.3V (5~10)	442uH±5%
LEAKAGE INDUCTANCE CH-3250	@1KHz,0.3V (5~10)	17.5μH MAX SHORT PIN 1,8
HI-POT TEST CH-9052	@ 2mA 3SEC (AC)	N1,N3<->N2 1.5 KV; N1<->N3 1.0 KV;

NOMINAL RATED POWER - 40 VA

LEAD FREE



DESCRIPTION	TRANSFORMER
Customer P/N	EFD30-150-350
FERRIWO P/N	FWPTEFD25H441J

SPEC. NO.	PS-2023-035	PREPARED		APPROVED	
-----------	-------------	----------	--	----------	--

SPECIFICATION

6. MATERIAL LIST :

ITEM	MATERIAL	SUPPLIER OR MANUFACTURER	TEMPRATING	
1	CORE EFD31/30/9	FW95 OR EQUIVALENT	HAINING FERRIWO ELECTRONICS CO., LTD.	
2	BOBBIN EFD30 (6+6)	PHENOLIC OR EQUIVALENT	CHANG CHUN PLASTICS CO., LTD. UL NO E59481	150°C
3	WIRE	2UEW-F	PACIFIC ELECTRIC WIRE&CABLE(SHENZHEN) CO. LTD UL NO E84081	155°C
4	TAPE	CT280	YAHUA STICKING TAPE CO.,LTD UL NO E165111	130°C
5	VARNISH	BC-346A	JOHN C DOLPH CO BC-346A UL NO E317427	130°C
6	FLUX	TF9100	LINAN GUITONG CHEMICAL TECHNICAL CO.,LTD	
7	TIN	Sn99.3Cu0.7	HAINING ZHUCHANG METAL FOIL CO;LTD	

LEAD FREE



DESCRIPTION	TRANSFORMER
Customer P/N	EFD30-150-350
FERRIWO P/N	FWPTEFD25H441J

SPEC. NO.

PS-2023-035

PREPARED



APPROVED

