



**SPECIFICATION FOR APPROVAL**

DESCRIPTION: TRANSFORMER  
 SPECIFICATION: EFD2501-1  
 PART NO: FWPTEFD25H751J-1  
 ISSUE DATE: 13 August 2022

MANUFACTURER APPROVAL		
PREPARED	CHECKED	APPROVED

CUSTOMER APPROVAL		
PREPARED	CHECKED	APPROVED

**Haining Ferriwo Electronics Co.,Ltd.**

Address:Block 13, Caohejing Technology Park, No.8,  
 Haining Avenue, Haining, Zhejiang 314400, China

TEL:+86-0573-87088701      FAX:+86-0573-87081130

www.ferriwo.com      sales@ferriwo.com



# SPECIFICATION

## 1. PHYSICAL DIMENSION(UNIT: m/m):

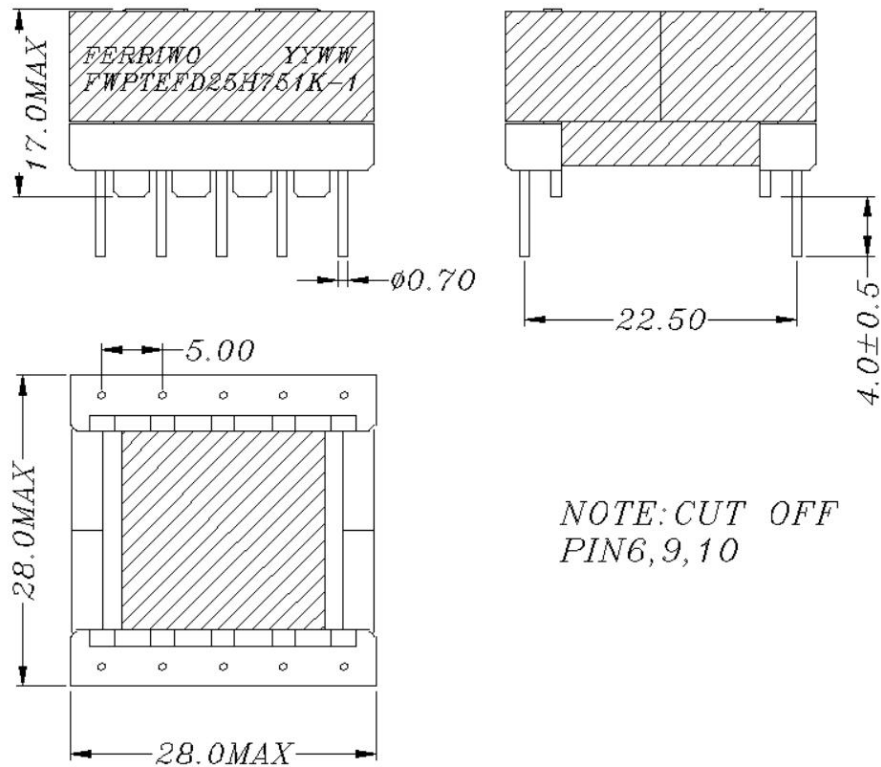

NOTE: CUT OFF  
PIN6, 9, 10

**LEAD FREE**

\*.Core fix tape 3Ts .

\*.The Label is placed on the product(see the picture above).

DIM	A	B	C	D	E	F	G	H				
SPEC												

	DESCRIPTION	TRANSFORMER
	Customer P/N	EFD2501-1
	FERRIWO P/N	FWPTEFD25H751J-1

SPEC. NO.	PS-2022-028	PREPARED		APPROVED	
-----------	-------------	----------	--	----------	--

# SPECIFICATION

## 2.WINDING TABLE:

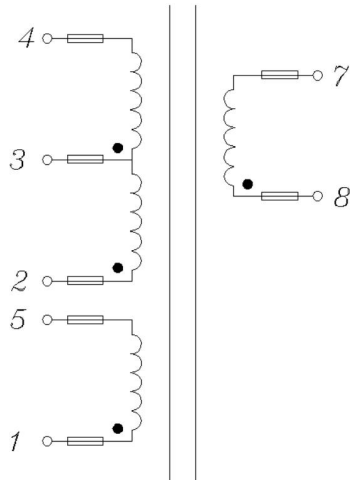

## 3.WINDING:

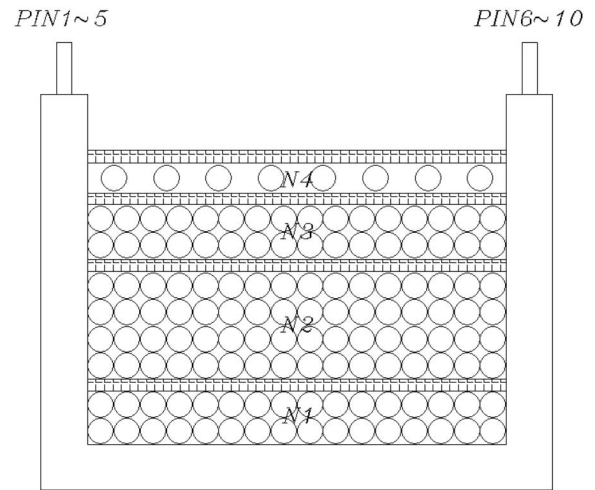



## 4.WINDING TABLE:

Winding NO.	Margin Tape	PIN	Wire &Wire Copper	Turns	Winding Type	Tape Layer	Tube
N1		2~3	0.1 $\phi$ x 10P	43Ts	CLOSE	2Ts	S=F $\geq$ 10mm
N2		8~7	0.1 $\phi$ x 25P	33Ts	CLOSE	2Ts	S=F $\geq$ 10mm
N3		3~4	0.1 $\phi$ x 10P	43Ts	CLOSE	2Ts	S=F $\geq$ 10mm
N4		1~5	0.2 $\phi$ x 1P	8Ts	SPREAD	2Ts	S=F $\geq$ 10mm

### NOTE:

- 1. Products should be vacuum impregnation
- \*VARNISH RATIO: 1:1
- \*VACUUM TIME: 15~20minutes
- \*BAKED TEMPERATURE : 120°C $\pm$ 10°C, 1~1.5hours

**LEAD FREE**

	DESCRIPTION	TRANSFORMER			
	Customer P/N	EFD2501-1			
	FERRIWO P/N	FWPTEFD25H751J-1			
SPEC. NO.	PS-2022-028	PREPARED		APPROVED	

# SPECIFICATION

## 5. ELECTRONICAL CHARACTERISTIC:

TEST CONDITION : TEMPERATURE AT 25°C

HUMIDITY AT 65 ±5% RH

TEST ITEM	TEST CONDITION	RESULT
INDUCTANCE CH-3250	@1KHz,1V (2~4)	750uH±5%
HI-POT TEST CH-9052	@ 2mA 3SEC (AC)	PRI<->SEC 1.5 KV;

NOMINAL RATED POWER - 100 VA

**LEAD FREE**



DESCRIPTION

TRANSFORMER

Customer P/N

EFD2501-1

FERRIWO P/N

FWPTEFD25H751J-1

SPEC. NO.

PS-2022-028

PREPARED



APPROVED



# SPECIFICATION

## 6. MATERIAL LIST :

ITEM		MATERIAL	SUPPLIER OR MANUFACTURER	TEMPRATING
1	CORE EFD25	FW95 OR EQUIVALENT	HAINING FERRIWO ELECTRONICS CO., LTD.	
2	BOBBIN	PHENOLIC OR EQUIVALENT	SUMITOMO BAKELITE CO., LTD. UL NO E41429	150°C
3	WIRE	2UEW-F	PACIFIC ELECTRIC WIRE&CABLE(SHENZHEN) CO. LTD UL NO E84081	155°C
4	TUBE	TEFLON TUBE	GREAT HOLDING INDUSTRIAL CO.,LTD UL NO E156256	200°C
5	TAPE	CT280	YAHUA STICKING TAPE CO.,LTD UL NO E165111	130°C
6	VARNISH	R-1038	JOHN C DOLPH CO BC-346A UL NO E317427	130°C
7	FLUX	TF9100	LINAN GUITONG CHEMICAL TECHNICAL CO.,LTD	
8	TIN	Sn99.3Cu0.7	HAINING ZHUCHANG METAL FOIL CO;LTD	

**LEAD FREE**



DESCRIPTION

TRANSFORMER

Customer P/N

EFD2501-1

FERRIWO P/N

FWPTEFD25H751J-1

SPEC. NO.

PS-2022-028

PREPARED



APPROVED

