



SPECIFICATION FOR APPROVAL

DESCRIPTION: TRANSFORMER
 SPECIFICATION: EFD25-90-500
 PART NO: FWPTEFD25H721K
 ISSUE DATE: 10 January 2023

MANUFACTURER APPROVAL		
PREPARED	CHECKED	APPROVED

CUSTOMER APPROVAL		
PREPARED	CHECKED	APPROVED

Haining Ferriwo Electronics Co.,Ltd.

Address:Block 13, Caohejing Technology Park, No.8,
 Haining Avenue, Haining, Zhejiang 314400, China

TEL:+86-0573-87088701 FAX:+86-0573-87081130

www.ferriwo.com sales@ferriwo.com

SPECIFICATION

1. PHYSICAL DIMENSION(UNIT: m/m):

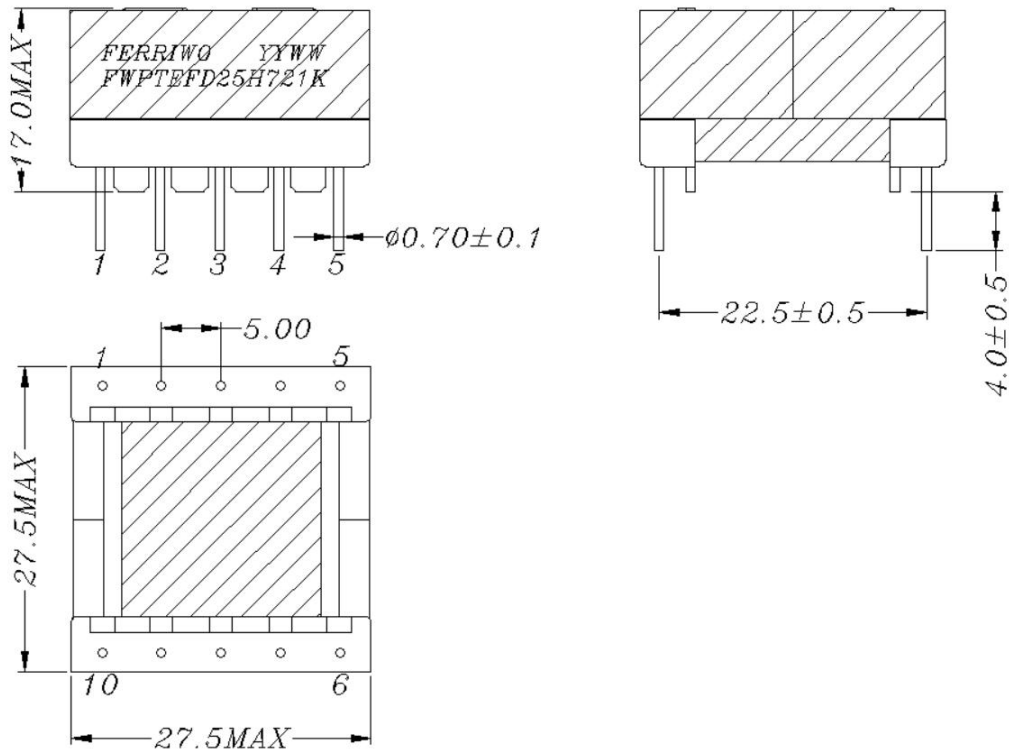

LEAD FREE

*.Core fix tape 3Ts .

*.The Label is placed on the product(see the picture above).

DIM	A	B	C	D	E	F	G	H				
SPEC												

	DESCRIPTION	TRANSFORMER
	Customer P/N	EFD25-90-500
	FERRIWO P/N	FWPTefd25H721K

SPEC. NO.	PS-2023-001	PREPARED		APPROVED	
-----------	-------------	----------	--	----------	--

SPECIFICATION

2.WINDING TABLE:

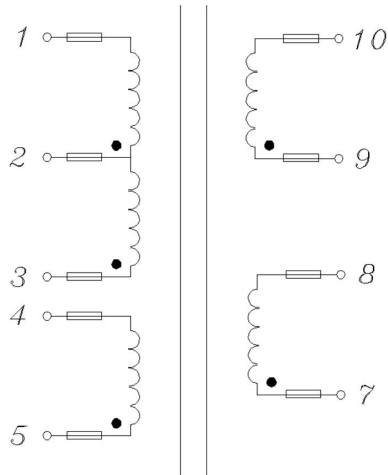

3.WINDING:

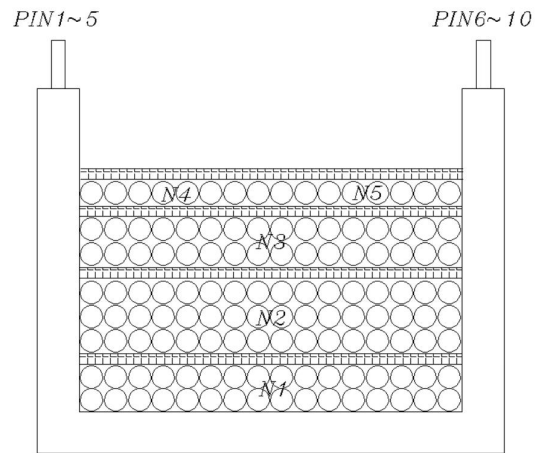

4.WINDING TABLE:

Winding NO.	Margin Tape	PIN	Wire &Wire Copper	Turns	Winding Type	Tape Layer	Tube
N1		3~2	0.1 ϕ x 10P	44Ts	CLOSE	2Ts	S=F \geq 10mm
N2		7~8	0.1 ϕ x 20P	52Ts	CLOSE	2Ts	S=F \geq 10mm
N3		2~1	0.1 ϕ x 10P	44Ts	CLOSE	2Ts	S=F \geq 10mm
N4		5~4	0.2 ϕ x 1P	14Ts	CLOSE	0Ts	S=F \geq 10mm
N5		9~10	0.2 ϕ x 1P	13Ts		2Ts	S=F \geq 10mm

NOTE:

- 1. Products should be vacuum impregnation
- *VARNISH RATIO: 1:1
- *VACUUM TIME: 15~20minutes
- *BAKED TEMPERATURE : 120°C \pm 10°C , 1~1.5hours

LEAD FREE



DESCRIPTION	TRANSFORMER
Customer P/N	EFD25-90-500
FERRIWO P/N	FWPTEFD25H721K

SPEC. NO.	PS-2023-001	PREPARED		APPROVED	
-----------	-------------	----------	--	----------	--

SPECIFICATION

5. ELECTRONICAL CHARACTERISTIC:

TEST CONDITION : TEMPERATURE AT 25°C

HUMIDITY AT 65 ±5% RH

TEST ITEM	TEST CONDITION	RESULT
INDUCTANCE CH-3250	@1KHz,0.3V (3~1)	720uH±10%
HI-POT TEST CH-9052	@ 2mA 3SEC (AC)	PRI<->SEC 1.5 KV; COIL<->CORE 1.5 KV;

NOMINAL RATED POWER - 100 VA

LEAD FREE



DESCRIPTION

TRANSFORMER

Customer P/N

EFD25-90-500

FERRIWO P/N

FWPTEFD25H721K

SPEC. NO.

PS-2023-001

PREPARED



APPROVED



SPECIFICATION

6. MATERIAL LIST :

ITEM	MATERIAL	SUPPLIER OR MANUFACTURER	TEMPRATING	
1	CORE EFD26	FW95 OR EQUIVALENT	HAINING FERRIWO ELECTRONICS CO., LTD.	
2	BOBBIN	PHENOLIC OR EQUIVALENT	SUMITOMO BAKELITE CO., LTD. UL NO E41429	150°C
3	WIRE	2UEW-F	PACIFIC ELECTRIC WIRE&CABLE(SHENZHEN) CO. LTD UL NO E84081	155°C
4	TUBE	TEFLON TUBE	GREAT HOLDING INDUSTRIAL CO.,LTD UL NO E156256	200°C
5	TAPE	CT280	YAHUA STICKING TAPE CO.,LTD UL NO E165111	130°C
6	VARNISH	R-1038	JOHN C DOLPH CO BC-346A UL NO E317427	130°C
7	FLUX	TF9100	LINAN GUITONG CHEMICAL TECHNICAL CO.,LTD	
8	TIN	Sn99.3Cu0.7	HAINING ZHUCHANG METAL FOIL CO;LTD	

LEAD FREE



DESCRIPTION

TRANSFORMER

Customer P/N

EFD25-90-500

FERRIWO P/N

FWPTEFD25H721K

SPEC. NO.

PS-2023-001

PREPARED



APPROVED

