



**SPECIFICATION FOR APPROVAL**

DESCRIPTION : Transformer  
 SPECIFICATION : EFD25-15.5mH  
 PART NO. : FWPTEFD25H153N  
 ISSUE DATE : 29 December 2021

MANUFACTURER APPROVAL		
PREPARED	CHECKED	APPROVED
工程部 夏晓凯 2021.12.29	工程部 潘玉财 2021.12.29	工程部 王永生 2021.12.29

CUSTOMER APPROVAL		
RECEIPT	CHECKED	APPROVED

<b>Haining Ferriwo Electronics Co., Ltd.</b>	
Address:Block 13, Caohejing Technology Park, No.8, Haining Avenue, Haining, Zhejiang , China	
TEL: +86-573-87088701	FAX: +86+573-87081130
www.ferriwo.com	sales@ferriwo.com



# SPECIFICATION

## 1. PHYSICAL DIMENSION(UNIT: m/m):

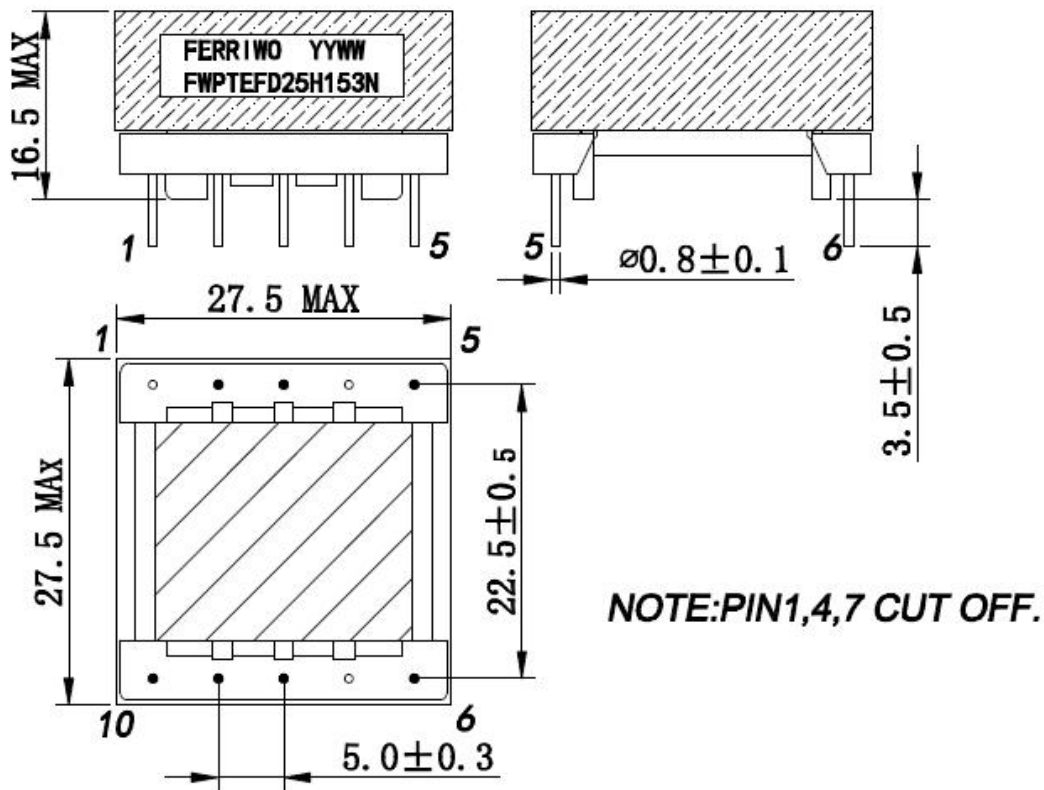

\*.Core fix tape 2Ts tape .

\*.The Marking is placed on the product(see the picture above).

**LEAD FREE**

DIM	a	b	c	d	e	f	g						
SPEC													
							DESCRIPTION		TRANSFORMER				
							Customer P/N		EFD25-15.5mH				
							FERRIWO P/N		FWPTEFD25H153N				
SPEC. NO.	PS-2021-088				PREPARED	夏晓凯 2021.12.29		APPROVED	王永生 2021.12.29				

# SPECIFICATION

## 2.WINDING TABLE:

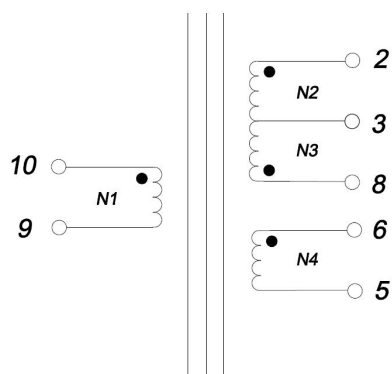

## 3.CROSS SECTION:

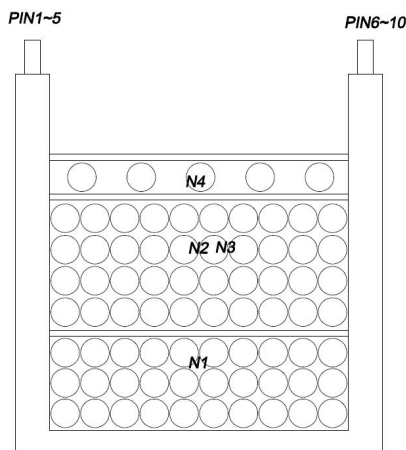

## 4.WINDING TABLE:

Winding NO.	Margin Tape	PIN	Wire &Wire Copper	Turns	Winding Type	Tape Layer	Tube
N1	0	10-9	0.23 ϕ x 2P	88Ts	CLOSE	2Ts	
N2	0	2-3	0.23 ϕ x 2P	49Ts	CLOSE	2Ts	
N3	0	3-8	0.23 ϕ x 2P	49Ts	CLOSE		
N4	0	6~5	0.23 ϕ x 2P	22Ts	SPREAD	2Ts	

NOTE:

- Products should be vacuum varnish.  
 \*VARNISH RATIO:1:2  
 \*VACUUM TIME:15~20minutes  
 \*BAKED TEMPERATURE:120°C±10°C,1~1.5huors .

**LEAD FREE**



DESCRIPTION	TRANSFORMER
Customer P/N	EFD25-15.5mH
FERRIWO P/N	FWPTEFD25H153N

SPEC. NO.	PS-2021-088	PREPARED	夏晓凯 2021.12.29	APPROVED	王永生 2021.12.29
-----------	-------------	----------	-------------------	----------	-------------------

# SPECIFICATION

4/5

## 5. ELECTRONICAL CHARACTERISTIC:

TEST CONDITION : TEMPERATURE AT 25°C

HUMIDITY AT 65 ±5% RH

TEST ITEM	TEST CONDITION	RESULT
INDUCTANCE CH-3250	@15KHz,1V (10~9)	15.5mH-20%/+30%
HI-POT TEST CH-9052	@ 2mA 3SEC (AC)	PRI<->SEC 1.5 KV, PRI<->CORE 1.5 KV

**LEAD FREE**



DESCRIPTION

TRANSFORMER

Customer P/N

EFD25-15.5mH

FERRIWO P/N

FWPTEFD25H153N

SPEC. NO.

PS-2021-088

PREPARED

夏晓凯  
2021.12.29

APPROVED

王永生  
2021.12.29

# SPECIFICATION

## 6. MATERIAL LIST :

ITEM	MATERIAL	SUPPLIER OR MANUFACTURER	TEMPRATING	
1	CORE EFD25/25/ 9	FW40 OR EQUIVALENT	HAINING FERRIWO ELECTRONICS CO., LTD.	
2	BOBBIN FWB2506	PHENOLIC OR EQUIVALENT	CHANG CHUN PLASTICS CO., LTD. UL NO E59481	150°C
3	WIRE	2UEW-F	PACIFIC ELECTRIC WIRE&CABLE(SHENZHEN) CO. LTD UL NO E84081	155°C
4	VARNISH	BC-346A	JOHN C DOLPH CO BC-346A UL NO E317427	130°C
5	FLUX	TF9100	LINAN GUITONG CHEMICAL TECHNICAL CO.,LTD	
6	TIN	Sn99.3Cu0.7	HAINING ZHUCHANG METAL FOIL CO;LTD	

**LEAD FREE**



DESCRIPTION	TRANSFORMER
Customer P/N	EFD25-15.5mH
FERRIWO P/N	FWPTEFD25H153N

SPEC. NO.	PS-2021-088	PREPARED	夏晓凯 2021.12.29	APPROVED	王永生 2021.12.29
-----------	-------------	----------	-------------------	----------	-------------------