





SPECIFICATION FOR APPROVAL

DESCRIPTION : Transformer
 SPECIFICATION : BIL30-T1-1
 PART NO. : FWPTEFD25H152J-1
 ISSUE DATE : May 19, 2023

MANUFACTURER APPROVAL		
PREPARED	CHECKED	APPROVED
		

CUSTOMER APPROVAL		
RECEIPT	CHECKED	APPROVED

Haining Ferriwo Electronics Co., Ltd.	
Address: Block 13, Caohejing Technology Park, No.8, Haining Avenue, Haining, Zhejiang 314400, China	
TEL: +86-0573-87088701	FAX: +86-0573-87081130
www.ferriwo.com	sales@ferriwo.com

SPECIFICATION

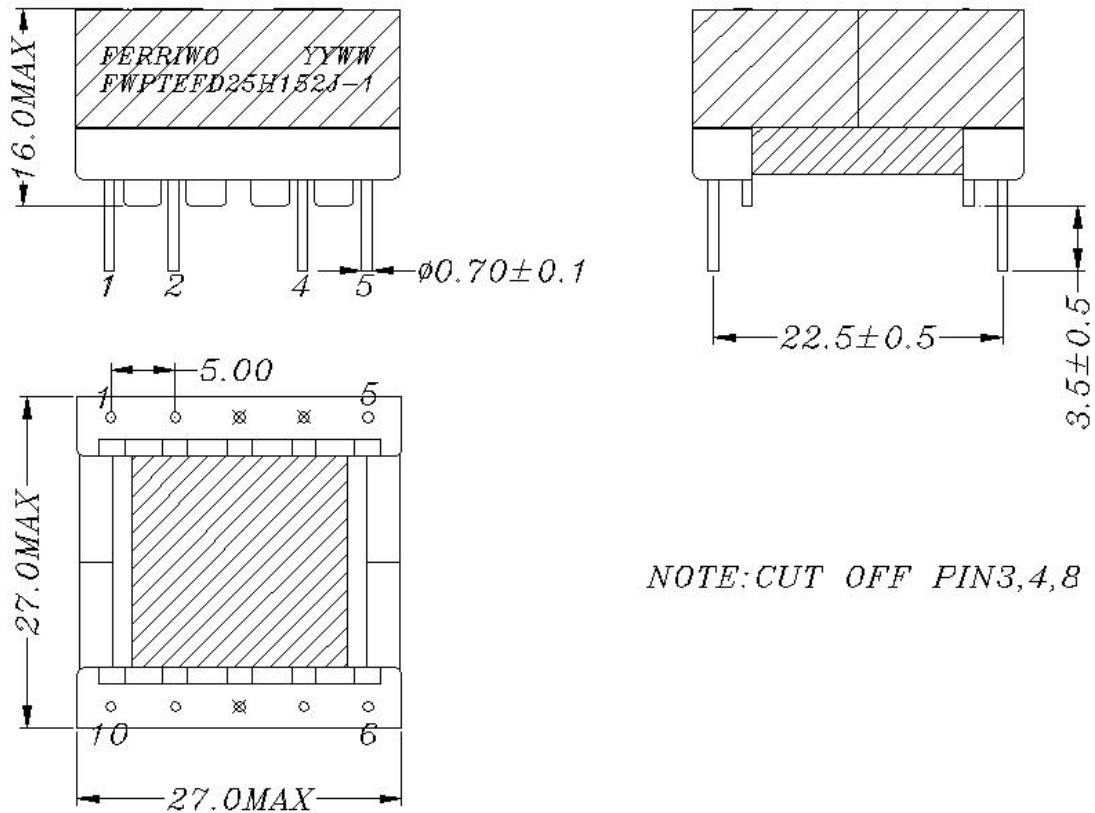

1. PHYSICAL DIMENSION(UNIT: m/m):



NOTE: CUT OFF PIN3,4,8

LEAD FREE

- *.Core fix tape 2Ts tape .
- *.The Label is placed on the product(see the picture above).

DIM	A	B	C	D	E	F	G	H				
SPEC												
FERRIWO						DESCRIPTION		TRANSFORMER				
						Customer P/N		BIL30-T1-1				
						FERRIWO P/N		FWPTEFD25H152J-1				
SPEC. NO.	PS-2023-027				PREPARED			APPROVED				

SPECIFICATION

2.WINDING TABLE:

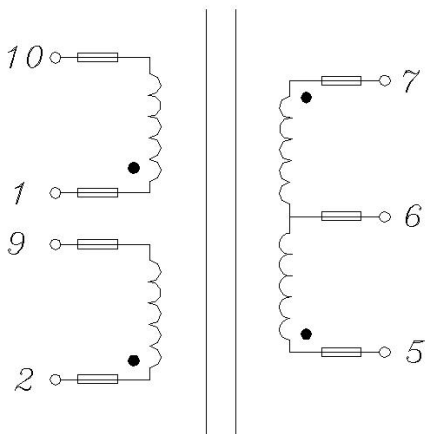

3.CROSS SECTION:

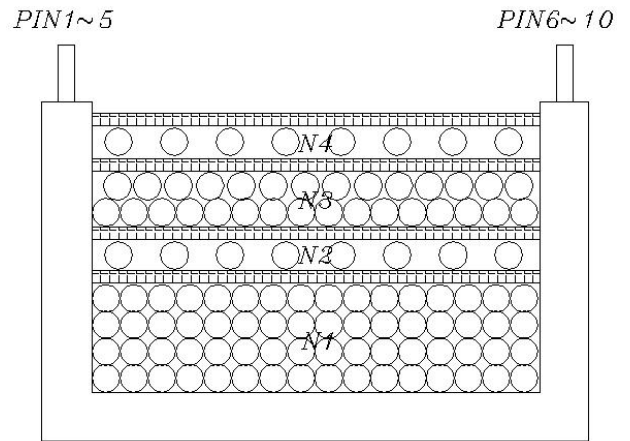

4.WINDING TABLE:

Winding NO.	Margin Tape	PIN	Wire &Wire Copper	Turns	Winding Type	Tape Layer	Tube
N1		1~10	0.12 ϕ x 6P	102Ts	CLOSE	2Ts	F=S \geq 10mm
N2		2~9	0.12 ϕ x 6P	11Ts	SPARSE	2Ts	F=S \geq 10mm
N3		5~6	0.4 ϕ x 1P TIW	38Ts	CLOSE	2Ts	F=S \geq 10mm
N4		7~6	0.2 ϕ x 1P TIW	11Ts	SPARSE	2Ts	F=S \geq 10mm

NOTE:

1.Products should be vacuum varnish.

*VARNISH RATIO:1:1

*VACUUM TIME:15~20minutes

*BAKED TEMPERATURE:120°C \pm 10°C,1~1.5huors

LEAD FREE



DESCRIPTION	TRANSFORMER
Customer P/N	BIL30-T1-1
FERRIWO P/N	FWPTEFD25H152J-1

SPEC. NO.	PS-2023-027	PREPARED		APPROVED	
-----------	-------------	----------	--	----------	--

SPECIFICATION

5. ELECTRONICAL CHARACTERISTIC:

TEST CONDITION : TEMPERATURE AT 25°C
HUMIDITY AT 65 ±5% RH

TEST ITEM	TEST CONDITION	RESULT
INDUCTANCE CH-3250	@1KHz,0.3V (1~10)	1.55mH±5%
HI-POT TEST CH-9052	@ 5mA 60SEC (AC)	P<->S 3.75KV

NOMINAL RATED POWER - 100 VA

LEAD FREE



DESCRIPTION	TRANSFORMER
Customer P/N	BIL30-T1-1
FERRIWO P/N	FWPTEFD25H152J-1

SPEC. NO.	PS-2023-027	PREPARED		APPROVED	
-----------	-------------	----------	--	----------	--

SPECIFICATION

6. MATERIAL LIST :

ITEM		MATERIAL	SUPPLIER OR MANUFACTURER	TEMPRATING
1	CORE EFD25	FW40 OR EQUIVALENT	HAINING FERRIWO ELECTRONICS CO., LTD.	
2	BOBBIN	PHENOLIC OR EQUIVALENT	SUMITOMO BAKELITE CO., LTD. UL NO E41429	150℃
3	WIRE	2UEW-F	PACIFIC ELECTRIC WIRE&CABLE(SHENZHEN) CO. LTD UL NO E84081	155℃
4	TRIPLE WIRE	TRIPLE. INSULATION. WIRE TRW(B)	GREAT LEOFLON INDUSTRIAL CO.,LTD UL NO E211989	130℃
5	TAPE	CT280	YAHUA STICKING TAPE CO.,LTD UL NO E165111	130℃
6	VARNISH	BC-346A	JOHN C DOLPH CO BC-346A UL NO E317427	130℃
7	TUBE	TEFLON TUBE	GREAT HOLDING INDUSTRIAL CO.,LTD UL NO E156256	200℃
8	FLUX	TF9100	LINAN GUITONG CHEMICAL TECHNICAL CO.,LTD	
9	TIN	Sn99.3Cu0.7	HAINING ZHUCHANG METAL FOIL CO;LTD	

LEAD FREE



DESCRIPTION	TRANSFORMER
Customer P/N	BIL30-T1-1
FERRIWO P/N	FWPTEFD25H152J-1

SPEC. NO.

PS-2023-027

PREPARED



APPROVED

