



SPECIFICATION FOR APPROVAL

DESCRIPTION : Transformer

SPECIFICATION : SMP-C3048

PART NO. : FWPTEF25V291K

ISSUE DATE : 16 July 2020

MANUFACTURER APPROVAL		
PREPARED	CHECKED	APPROVED
工程部 夏晓凯 2020.07.16	工程部 潘玉财 2020.07.16	工程部 王永生 2020.07.16

CUSTOMER APPROVAL		
RECEIPT	CHECKED	APPROVED

Haining Ferriwo Electronics Co., Ltd.	
Address: Block 13, Caohejing Technology Park, No.8, Haining Avenue, Haining, Zhejiang , China	
TEL: +86-573-87088701	FAX: +86+573-87081130
www.ferriwo.com	sales@ferriwo.com

SPECIFICATION

1. PHYSICAL DIMENSION(UNIT: m/m):

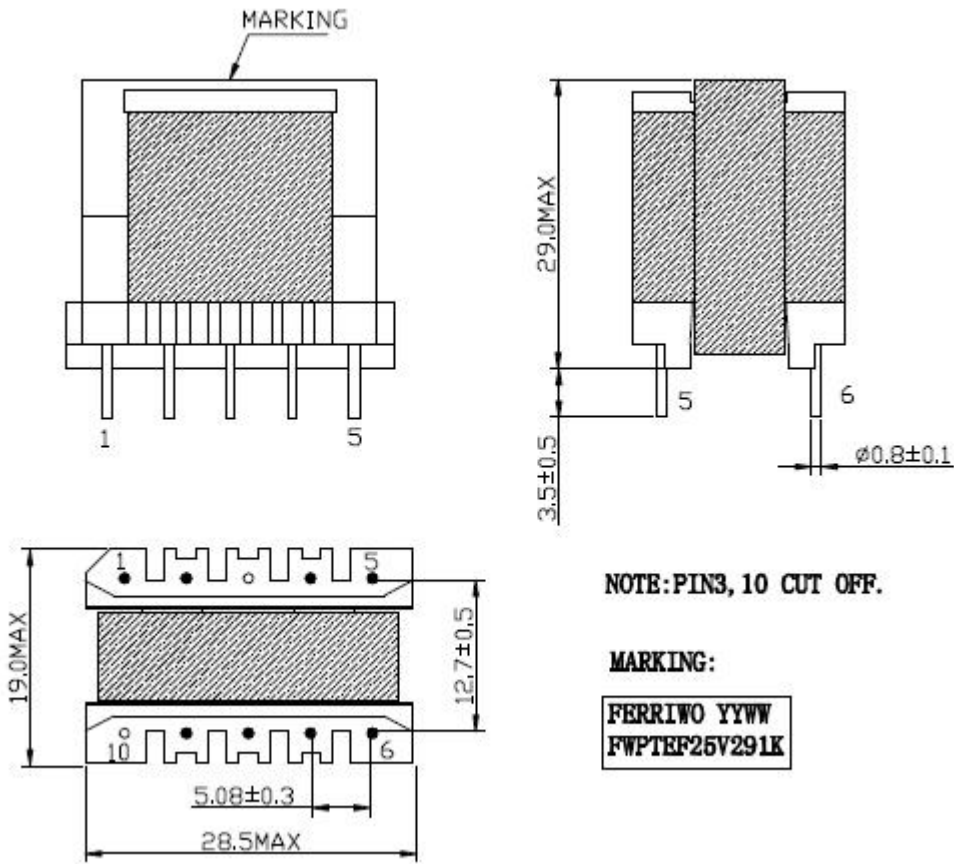

NOTE: PIN3, 10 CUT OFF.

MARKING:

FERRIWO YYWW
FWPTEF25V291K

LEAD FREE

*.Core fix tape 2Ts .

*.The Label is placed on the product(see the picture above).

DIM	A	B	C	D	E	F	G	H				
SPEC												
						DESCRIPTION		TRANSFORMER				
						Customer P/N		SMP-C3048				
						FERRIWO P/N		FWPTEF25V291K				
SPEC. NO.	PS-2020-033				PREPARED	夏晓凯 2020.07.16		APPROVED	王永生 2020.07.16			

SPECIFICATION

3/5

2. SCHEMATIC DIAGRAM:

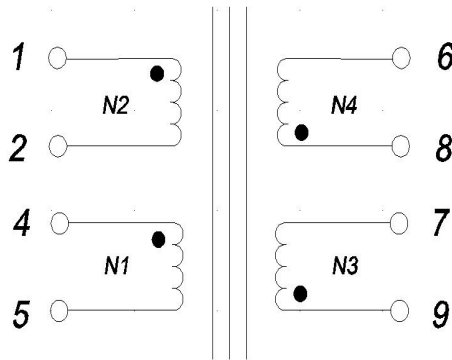

3. CROSS SECTION

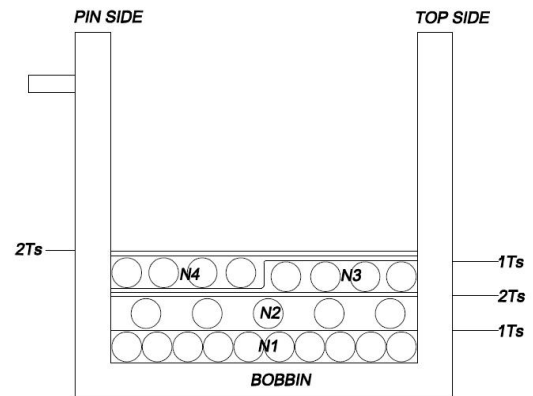

4. WINDING TABLE:

Winding NO.	Margin Tape	PIN	Wire & Wire Copper	Turns	Winding Type	Tape Layer	Tube
N1		4~5	0.35 ϕ x1P	34Ts	CLOSE	1Ts	
N2		1~2	0.35 ϕ x2P	5Ts	SPREAD	2Ts	
N3		9~7	0.40 ϕ x2P	5Ts	SPREAD	1Ts	
N4		8~6	0.40 ϕ x2P	5Ts	SPREAD	2Ts	

NOTE:

1. Products should be vacuum varnish.

*VARNISH RATIO:1:2

*VACUUM TIME:15~20minutes

*BAKED TEMPERATURE:120°C \pm 10°C, 1~1.5huors

LEAD FREE

FERRIWO

DESCRIPTION

TRANSFORMER

Customer P/N

SMP-C3048

FERRIWO P/N

FWPTEF25V291K

SPEC. NO.

PS-2020-033

PREPARED

夏晓凯
2020.07.16

APPROVED

王永生
2020.07.16

SPECIFICATION

4/5

5. ELECTRONICAL CHARACTERISTIC:

TEST CONDITION : TEMPERATURE AT 25°C

HUMIDITY AT 65 ±5% RH

TEST ITEM	TEST CONDITION	RESULT
INDUCTANCE CH-3250	@1KHz,1V (4~5)	290uH±10%
DCR CH-502	(4~5)	350mΩ MAX
HI-POT TEST CH-9052	@ 5mA 1SEC (AC)	P<->S 1.5 KV

LEAD FREE



DESCRIPTION

TRANSFORMER

Customer P/N

SMP-C3048

FERRIWO P/N

FWPTEF25V291K

SPEC. NO.

PS-2020-033

PREPARED

夏晓凯
2020.07.16

APPROVED

王永生
2020.07.16

SPECIFICATION

5/5

6. MATERIAL LIST :

ITEM		MATERIAL	SUPPLIER OR MANUFACTURER	TEMPRATING
1	CORE EF25	FW40 OR EQUIVALENT	HAINING FERRIWO ELECTRONICS CO., LTD.	
2	BOBBIN FWB2526	PHENOLIC OR EQUIVALENT	CHANG CHUN PLASTICS CO., LTD. UL NO E59481	150℃
3	WIRE	2UEW	PACIFIC ELECTRIC WIRE&CABLE(SHENZHEN) CO. LTD UL NO E84081	130℃
4	TAPE	CT280	YAHUA STICKING TAPE CO.,LTD UL NO E165111	130℃
5	VARNISH	BC-346A	JOHN C DOLPH CO BC-346A UL NO E317427	130℃
6	FLUX	TF9100	LINAN GUITONG CHEMICAL TECHNICAL CO.,LTD	
7	TIN	Sn99.3Cu0.7	HAINING ZHUCHANG METAL FOIL CO;LTD	

LEAD FREE



DESCRIPTION	TRANSFORMER
Customer P/N	SMP-C3048
FERRIWO P/N	FWPTEF25V291K

SPEC. NO.

PS-2020-033

PREPARED

夏晓凯
2020.07.16

APPROVED

王永生
2020.07.16