





SPECIFICATION FOR APPROVAL

DESCRIPTION : Transformer
 SPECIFICATION : 15-12C2
 PART NO. : FWPTEF20H981J
 ISSUE DATE : 31 August 2022

MANUFACTURER APPROVAL		
PREPARED	CHECKED	APPROVED
		

CUSTOMER APPROVAL		
RECEIPT	CHECKED	APPROVED

Haining Ferriwo Electronics Co., Ltd.	
Address: Block 13, Caohejing Technology Park, No.8, Haining Avenue, Haining, Zhejiang 314400, China	
TEL: +86-573-87088701	FAX: +86+573-87081130
www.ferriwo.com	sales@ferriwo.com

SPECIFICATION

1. PHYSICAL DIMENSION(UNIT: m/m):

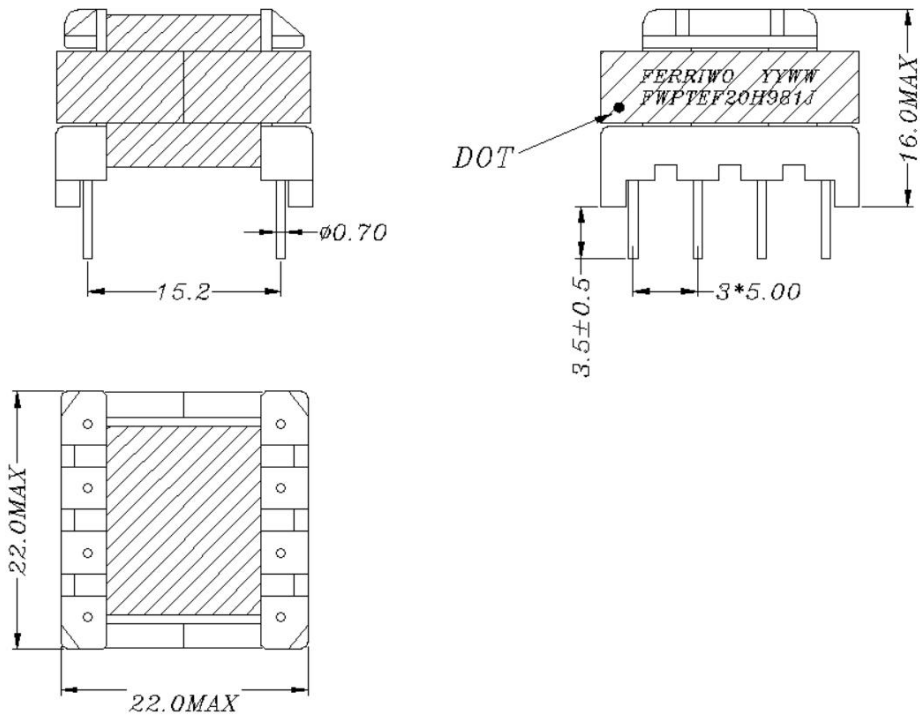

LEAD FREE

- *.Core fix tape 3Ts .
- *.The Label is placed on the product(see the picture above).
- *.Marked the **PIN #1** by black dot!

DIM	A	B	C	D	E	F	G	H				
SPEC												
						DESCRIPTION			TRANSFORMER			
						Customer P/N			15-12C2			
						FERRIWO P/N			FWPTEF20H981J			
SPEC. NO.	PS-2022-030				PREPARED			APPROVED				

SPECIFICATION

2. SCHEMATIC DIAGRAM:

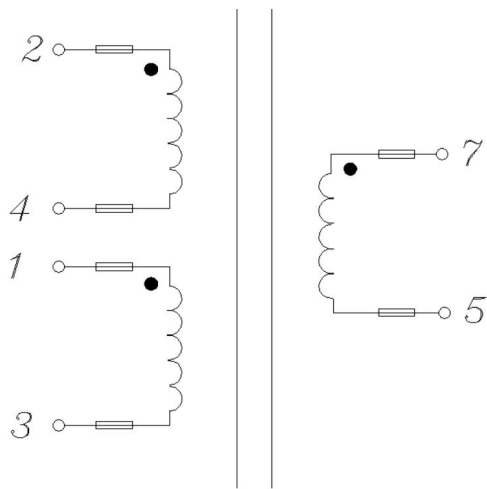

3. CROSS SECTION

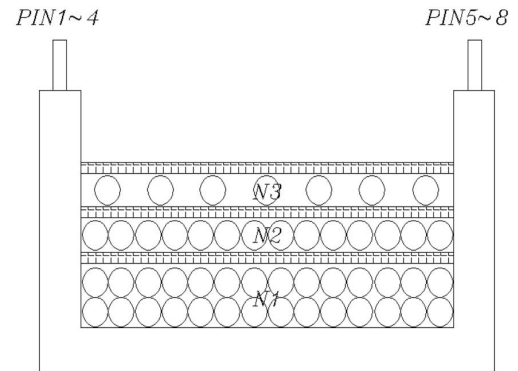

4. WINDING TABLE:

Winding NO.	Margin Tape	PIN	Wire & Wire Copper	Turns	Winding Type	Tape Layer	Tube
N1		2~4	0.28 ϕ x1P	70Ts	CLOSE	2Ts	S=F:10mm
N2		7~5	0.35 ϕ x1P	20Ts	CLOSE	2Ts	S=F:10mm
N3		1~3	0.28 ϕ x1P	18Ts	SPREAD	2Ts	S=F:10mm

NOTE:

- 1. Products should be vacuum varnish.
 - *VARNISH RATIO:1:2
 - *VACUUM TIME:15~20minutes
 - *BAKED TEMPERATURE:120°C±10°C, 1~1.5huors

LEAD FREE

DESCRIPTION	TRANSFORMER
Customer P/N	15-12C2
FERRIWO P/N	FWPTEF20H981J

SPEC. NO.	PS-2022-030	PREPARED		APPROVED	
-----------	-------------	----------	--	----------	--

SPECIFICATION

4/5

5. ELECTRONICAL CHARACTERISTIC:

TEST CONDITION : TEMPERATURE AT 25°C

HUMIDITY AT 65 ±5% RH

TEST ITEM	TEST CONDITION	RESULT
INDUCTANCE CH-3250	@10KHz,1V (2~4)	980uH±5%
HI-POT TEST CH-9052	@ 2mA 3SEC (AC)	N1<->N3 1.0 KV; N1,N2<->N3 3.0KV;

RATED POWER - 70 VA

LEAD FREE



DESCRIPTION

TRANSFORMER

Customer P/N

15-12C2

FERRIWO P/N

FWPTEF20H981J

SPEC. NO.

PS-2022-030

PREPARED



APPROVED



SPECIFICATION

5/5

6. MATERIAL LIST :

ITEM		MATERIAL	SUPPLIER OR MANUFACTURER	TEMPRATING
1	CORE EE20/20/6	FW95 OR EQUIVALENT	HAINING FERRIWO ELECTRONICS CO., LTD.	
2	BOBBIN EF20(4+4)	PHENOLIC OR EQUIVALENT	CHANG CHUN PLASTICS CO., LTD. UL NO E59481	150℃
3	WIRE	2UEW-F	PACIFIC ELECTRIC WIRE&CABLE(SHENZHEN) CO. LTD UL NO E84081	155℃
4	TAPE	CT280	YAHUA STICKING TAPE CO.,LTD UL NO E165111	130℃
5	VARNISH	BC-346A	JOHN C DOLPH CO BC-346A UL NO E317427	130℃
6	TUBE	TEFLON TUBE	GREAT HOLDING INDUSTRIAL CO.,LTD UL NO E156256	200℃
7	FLUX	TF9100	LINAN GUITONG CHEMICAL TECHNICAL CO.,LTD	
8	TIN	Sn99.3Cu0.7	HAINING ZHUCHANG METAL FOIL CO;LTD	

LEAD FREE



DESCRIPTION

TRANSFORMER

Customer P/N

15-12C2

FERRIWO P/N

FWPTEF20H981J

SPEC. NO.

PS-2022-030

PREPARED



APPROVED

