



**SPECIFICATION FOR APPROVAL**

DESCRIPTION : Transformer  
 SPECIFICATION : EF20-711uH  
 PART NO. : FWPTEF20H711J-1  
 ISSUE DATE : 13 November 2021

MANUFACTURER APPROVAL		
PREPARED	CHECKED	APPROVED
工程部 夏晓凯 2021.11.13	工程部 潘玉财 2021.11.13	工程部 王永生 2021.11.13

CUSTOMER APPROVAL		
RECEIPT	CHECKED	APPROVED

Haining Ferriwo Electronics Co., Ltd.	
Address:Block 13, Caohejing Technology Park, No.8, Haining Avenue, Haining, Zhejiang , China	
TEL: +86-573-87088701	FAX: +86+573-87081130
www.ferriwo.com	sales@ferriwo.com



# SPECIFICATION

## 1. PHYSICAL DIMENSION(UNIT: m/m):

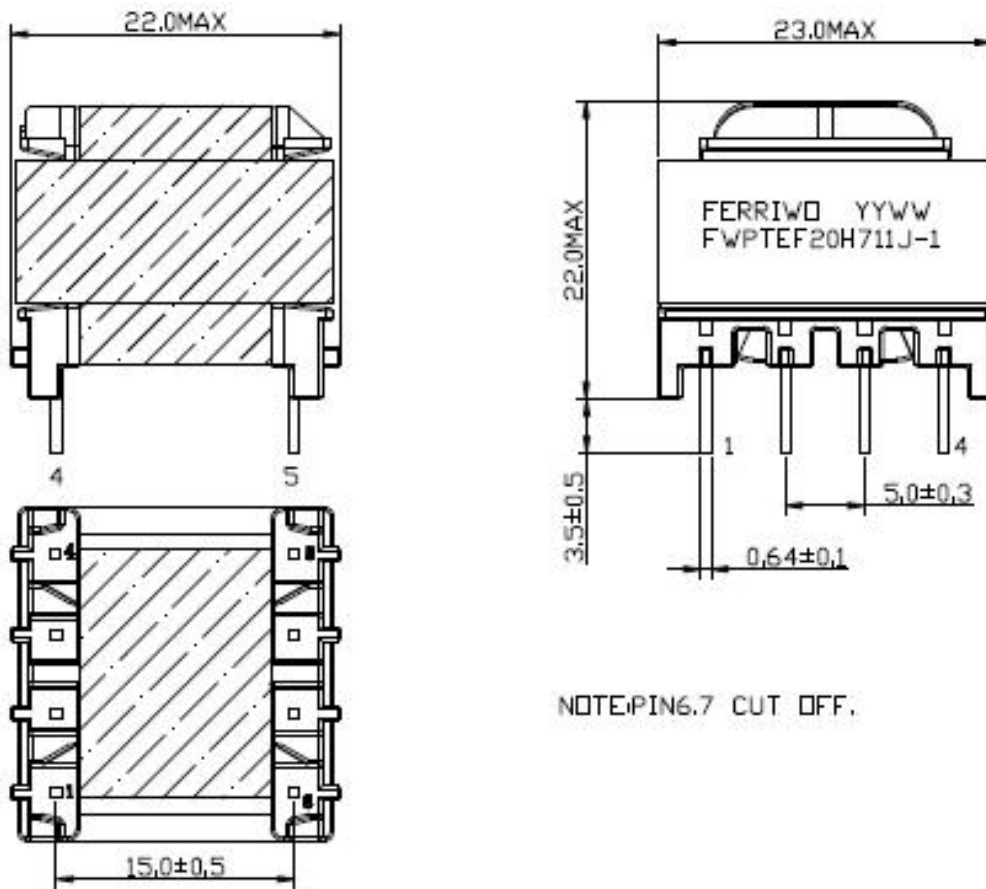

NOTE: PIN 6,7 CUT OFF.

**LEAD FREE**

\*.Core fix tape 2Ts tape .

DIM	A	B	C	D	E	F	G	H				
SPEC												
						DESCRIPTION		TRANSFORMER				
						Customer P/N		EF20-711uH				
						FERRIWO P/N		FWPTEF20H711J-1				
SPEC. NO.	PS-2021-086				PREPARED	夏晓凯 2021.11.13		APPROVED	王永生 2021.11.13			

# SPECIFICATION

## 2. SCHEMATIC DIAGRAM:

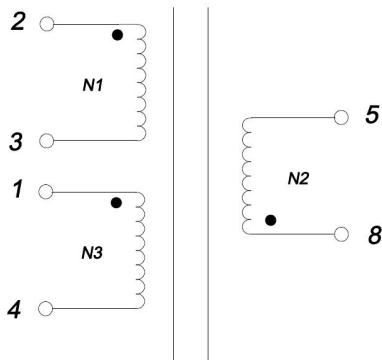

## 3. CROSS SECTION:

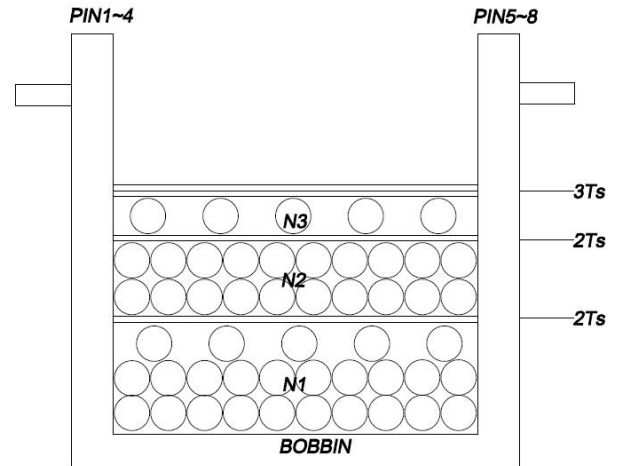

## 4. WINDING TABLE:

Winding NO.	Margin Tape	PIN	Wire & Wire Copper	Turns	Winding Type	Tape Layer	Tube
N1		2-3	0.30 $\phi$ x1P	80Ts	CLOSE+SPREAD	2Ts	
N2		8-5	0.32 $\phi$ x1P	67Ts	CLOSE	2Ts	
N3		1-4	0.30 $\phi$ x1P	11Ts	SPREAD	3Ts	

### NOTE:

1. Products should be vacuum varnish.

\*VARNISH RATIO:1:2

\*VACUUM TIME:15~20minutes

\*BAKED TEMPERATURE:120°C $\pm$ 10°C, 1~1.5huors

**LEAD FREE**

**FERRIWO**

DESCRIPTION

TRANSFORMER

Customer P/N

EF20-711uH

FERRIWO P/N

FWPTEF20H711J-1

SPEC. NO.

PS-2021-086

PREPARED

夏晓凯  
2021.11.13

APPROVED

王永生  
2021.11.13

# SPECIFICATION

4/5

## 5. ELECTRONICAL CHARACTERISTIC:

TEST CONDITION : TEMPERATURE AT 25°C

HUMIDITY AT 65 ±5% RH

TEST ITEM	TEST CONDITION	RESULT
INDUCTANCE CH-3250	@10KHz,1V (2~3)	711uH±5%
HI-POT TEST CH-9052	@ 5mA 3SEC (AC)	P<->S 2.5 KV;

**LEAD FREE**



DESCRIPTION

TRANSFORMER

Customer P/N

EF20-711uH

FERRIWO P/N

FWPTEF20H711J-1

SPEC. NO.

PS-2021-086

PREPARED

夏晓凯  
2021.10.25

APPROVED

王永生  
2021.10.25

# SPECIFICATION

5/5

## 6. MATERIAL LIST :

ITEM		MATERIAL	SUPPLIER OR MANUFACTURER	TEMPRATING
1	CORE EF21/10/8.8	FW44 OR EQUIVALENT	HAINING FERRIWO ELECTRONICS CO., LTD.	
2	BOBBIN EF20 (4+4)	PET OR EQUIVALENT	EIDUPONT DE NERMOURS&COINC UL NO E69578	150℃
3	WIRE	2UEW-F	PACIFIC ELECTRIC WIRE&CABLE(SHENZHEN) CO. LTD UL NO E84081	155℃
4	TAPE	CT280	YAHUA STICKING TAPE CO.,LTD UL NO E165111	130℃
5	VARNISH	BC-346A	JOHN C DOLPH CO BC-346A UL NO E317427	130℃
6	FLUX	TF9100	LINAN GUITONG CHEMICAL TECHNICAL CO.,LTD	
7	TIN	Sn99.3Cu0.7	HAINING ZHUCHANG METAL FOIL CO;LTD	

**LEAD FREE**



DESCRIPTION

TRANSFORMER

Customer P/N

EF20-711uH

FERRIWO P/N

FWPTEF20H711J-1

SPEC. NO.

PS-2021-086

PREPARED

夏晓凯  
2021.11.13

APPROVED

王永生  
2021.11.13