





A PASSION FOR
LIGHTING TECHNOLOGY



SPECIFICATION FOR APPROVAL

DESCRIPTION: Transformer
 SPECIFICATION: _____
 PART NO: FWPTEF12.6V103K
 ISSUE DATE: 2024-8-13

MANUFACTURER APPROVAL		
PREPARED	CHECKED	APPROVED
		

CUSTOMER APPROVAL		
PREPARED	CHECKED	APPROVED

FOSO POWER TECHNOLOGY CO., LTD.	
Address: Block 13, Caohejing Technology Park, No.8, Haining Avenue, Haining, Zhejiang 314400, China	
TEL: +86-573-8787-3600	FAX: +86-0573-87081130
www.fosopower.com	contact@fosopower.com

1. PHYSICAL DIMENSION(UNIT: m/m):

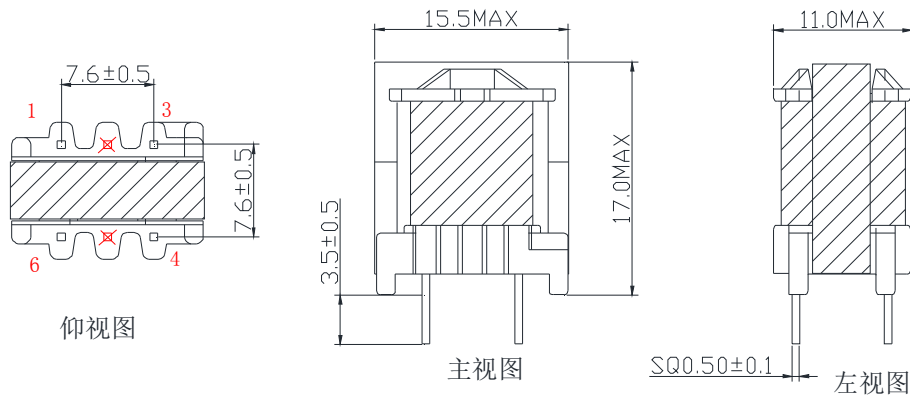

NOTE:

CUT OFF PIN: 2 , 5

LEAD FREE

*.Core fix tape 2Ts .

*.The Label is placed on the product(see the picture above).

DIM	A	B	C	D	E	F	G	H				
SPEC												

<p style="font-size: small;">A PASSION FOR LIGHTING TECHNOLOGY</p>	DESCRIPTION	Transformer
	Customer P/N	
	FERRIWO P/N	FWPTEF12.6V103K

SPEC. NO.	PS-2023-092	PREPARED		APPROVED	
-----------	-------------	----------	--	----------	--

SPECIFICATION

2.WINDING TABLE:

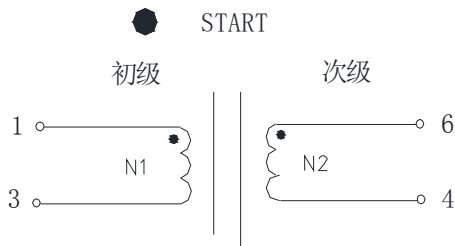

3.WINDING:

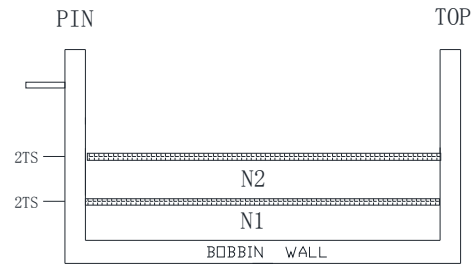



4.WINDING TABLE:

Winding	槽 (Slot)				wire	Tube		turn (TS)	Tape	Winding type
	start		end			start	end			
N1	1		3		QA-1 ϕ 0.18mm	/	/	100	0.025*8.0*3TS	Close
N2	6		4		QA-1 ϕ 0.32mm*2P	/	/	1	0.025*8.0*3TS	intersection
沿着磁芯方向包									0.025*3.5*3TS	

NOTE:

- 1. Products should be vacuum impregnation
- *VARNISH RATIO: 1:1
- *VACUUM TIME: 15~20minutes
- *BAKED TEMPERATURE : 120°C±10°C, 1~1.5hours

LEAD FREE

 <p>A PASSION FOR LIGHTING TECHNOLOGY</p>	DESCRIPTION	Transformer			
	Customer P/N				
	FERRIWO P/N	FWPTEF12.6V103K			
SPEC. NO.	PS-2023-092	PREPARED		APPROVED	

5. ELECTRONICAL CHARACTERISTIC:

**TEST CONDITION : TEMPERATURE AT 25°C
HUMIDITY AT 65 ±5% RH**

Item	测试端	Result	Testing condition	Testing machine
Inductance	1-3	10mH Min	1KHz, 0.3V	3250A
Ts rate	N1: N2	100:1		

NOMINAL RATED POWER - 30 VA

6. Note:

- ①:Winding direction is winding clockwise rotation
- ②:Bobbin insertion fixture direction is shown below:

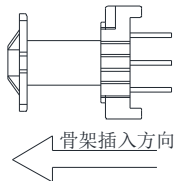

LEAD FREE

	A PASSION FOR LIGHTING TECHNOLOGY	DESCRIPTION	Transformer		
		Customer P/N			
		FERRIWO P/N	FWPTEF12.6V103K		
SPEC. NO.	PS-2023-092	PREPARED		APPROVED	

SPECIFICATION

6. MATERIAL LIST :

ITEM	MATERIAL	SUPPLIER OR MANUFACTURER	TEMPRATING
1	CORE FW95 OR EQUIVALENT	HAINING FERRIWO ELECTRONICS CO., LTD.	
2	BOBBIN FWB1201 OR EQUIVALENT	SUMITOMO BAKELITE CO., LTD. UL NO E41429	150°C
3	wire QA-1 0.18mm QA-1 0.32mm	PACIFIC ELECTRIC WIRE&CABLE(SHENZHEN) CO. LTD UL NO E84081	155°C
4	TAPE CT280	YAHUA STICKING TAPE CO.,LTD UL NO E165111	130°C
5	VARNISH R-1038	JOHN C DOLPH CO BC-346A UL NO E317427	130°C
6	FLUX TF9100	LINAN GUITONG CHEMICAL TECHNICAL CO.,LTD	
7	TIN Sn99.3Cu0.7	HAINING ZHUCHANG METAL FOIL CO;LTD	

LEAD FREE



A PASSION FOR
LIGHTING TECHNOLOGY

DESCRIPTION

Transformer

Customer P/N

FERRIWO P/N

FWPTEF12.6V103K

SPEC. NO.

PS-2023-092

PREPARED



APPROVED

