





SPECIFICATION FOR APPROVAL

DESCRIPTION : Transformer
 SPECIFICATION : EER2834-090-1050
 PART NO. : FWPTEER2834H101J
 ISSUE DATE : June 2, 2023

MANUFACTURER APPROVAL		
PREPARED	CHECKED	APPROVED
		

CUSTOMER APPROVAL		
RECEIPT	CHECKED	APPROVED

Haining Ferriwo Electronics Co., Ltd.	
Address: Block 13, Caohejing Technology Park, No.8, Haining Avenue, Haining, Zhejiang , China	
TEL: +86-573-87088701	FAX: +86+573-87081130
www.ferriwo.com	sales@ferriwo.com

SPECIFICATION

1. PHYSICAL DIMENSION(UNIT: m/m):

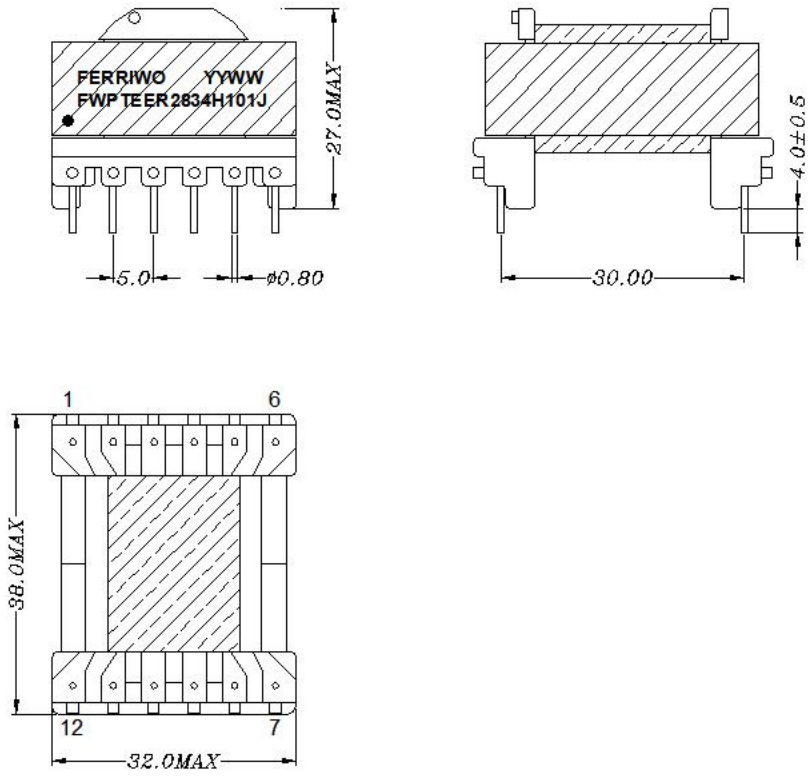

LEAD FREE

- *.Core fix tape 2Ts tape .
- *.The Label is placed on the product(see the picture above).
- *.Marked the **PIN #1** by black dot!

DIM	A	B	C	D	E	F	G	H				
SPEC												
						DESCRIPTION		TRANSFORMER				
						Customer P/N		EER2834-090-1050				
						FERRIWO P/N		FWPTEER2834H101J				
SPEC. NO.	PS-2023-037				PREPARED			APPROVED				

SPECIFICATION

2. SCHEMATIC DIAGRAM:

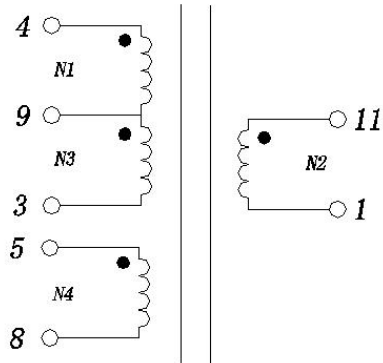

3. CROSS SECTION:

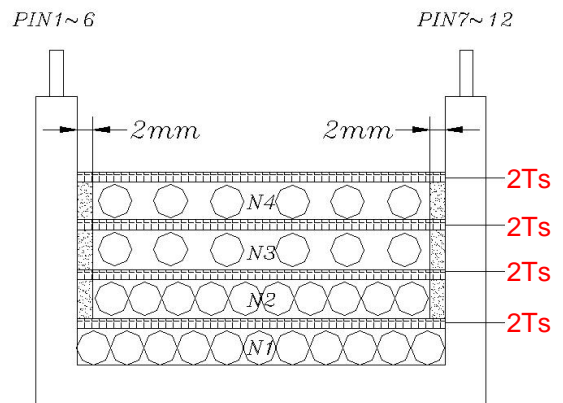

4. WINDING TABLE:

Winding NO.	Margin Tape	PIN	Wire & Wire Copper	Turns	Winding Type	Tape Layer	Tube
N1		4-9	0.1 ϕ x20P	25Ts	CLOSE	2Ts	
N2		11-1	0.3 ϕ x2P	29Ts	CLOSE	2Ts	
N3		9-3	0.1 ϕ x20P	19Ts	SPREAD	2Ts	
N4		5-8	0.3 ϕ x1P	6Ts	SPREAD	2Ts	

NOTE:

1. Products should be vacuum varnish.

*VARNISH RATIO:1:2

*VACUUM TIME:15~20minutes

*BAKED TEMPERATURE:120°C±10°C, 1~1.5huors

LEAD FREE

DESCRIPTION

TRANSFORMER

Customer P/N

EER2834-090-1050

FERRIWO P/N

FWPTEER2834H101J

SPEC. NO.

PS-2023-037

PREPARED



APPROVED



SPECIFICATION

5. ELECTRONICAL CHARACTERISTIC:

TEST CONDITION : TEMPERATURE AT 25°C
HUMIDITY AT 65 ±5% RH

TEST ITEM	TEST CONDITION	RESULT
INDUCTANCE CH-3250	@1KHz,0.3V (4~9)	100uH±5%
LEAKAGE INDUCTANCE CH-3250	@1KHz,0.3V (4~3)	11.5μH MAX SHORT PIN 1,11
HI-POT TEST CH-9052	@ 2mA 3SEC (AC)	N1,N3,N4<->N2 2.0 KV; N1,N3<->N4 1.5 KV;

NOMINAL RATED POWER - 60 VA

LEAD FREE



DESCRIPTION	TRANSFORMER
Customer P/N	EER2834-090-1050
FERRIWO P/N	FWPTEER2834H101J

SPEC. NO.	PS-2023-037	PREPARED		APPROVED	
-----------	-------------	----------	--	----------	--

SPECIFICATION

5/5

6. MATERIAL LIST :

ITEM		MATERIAL	SUPPLIER OR MANUFACTURER	TEMPRATING
1	CORE EER28/34/11	FW95 OR EQUIVALENT	HAINING FERRIWO ELECTRONICS CO., LTD.	
2	BOBBIN EER28 (6+6)	PHENOLIC OR EQUIVALENT	CHANG CHUN PLASTICS CO., LTD. UL NO E59481	150°C
3	WIRE	2UEW-F	PACIFIC ELECTRIC WIRE&CABLE(SHENZHEN) CO. LTD UL NO E84081	155°C
4	TAPE	CT280	YAHUA STICKING TAPE CO.,LTD UL NO E165111	130°C
5	VARNISH	BC-346A	JOHN C DOLPH CO BC-346A UL NO E317427	130°C
6	FLUX	TF9100	LINAN GUITONG CHEMICAL TECHNICAL CO.,LTD	
7	TIN	Sn99.3Cu0.7	HAINING ZHUCHANG METAL FOIL CO;LTD	

LEAD FREE



DESCRIPTION

TRANSFORMER

Customer P/N

EER2834-090-1050

FERRIWO P/N

FWPTEER2834H101J

SPEC. NO.

PS-2023-037

PREPARED



APPROVED

