





**SPECIFICATION FOR APPROVAL**

DESCRIPTION : Transformer  
 SPECIFICATION : EER2834-170-700  
 PART NO. : FWPTEER2834H101J-1  
 ISSUE DATE : June 2, 2023

MANUFACTURER APPROVAL		
PREPARED	CHECKED	APPROVED
		

CUSTOMER APPROVAL		
RECEIPT	CHECKED	APPROVED

Haining Ferriwo Electronics Co., Ltd.	
Address: Block 13, Caohejing Technology Park, No.8, Haining Avenue, Haining, Zhejiang, China	
TEL: +86-573-87088701	FAX: +86+573-87081130
www.ferriwo.com	sales@ferriwo.com



# SPECIFICATION

## 1. PHYSICAL DIMENSION(UNIT: m/m):

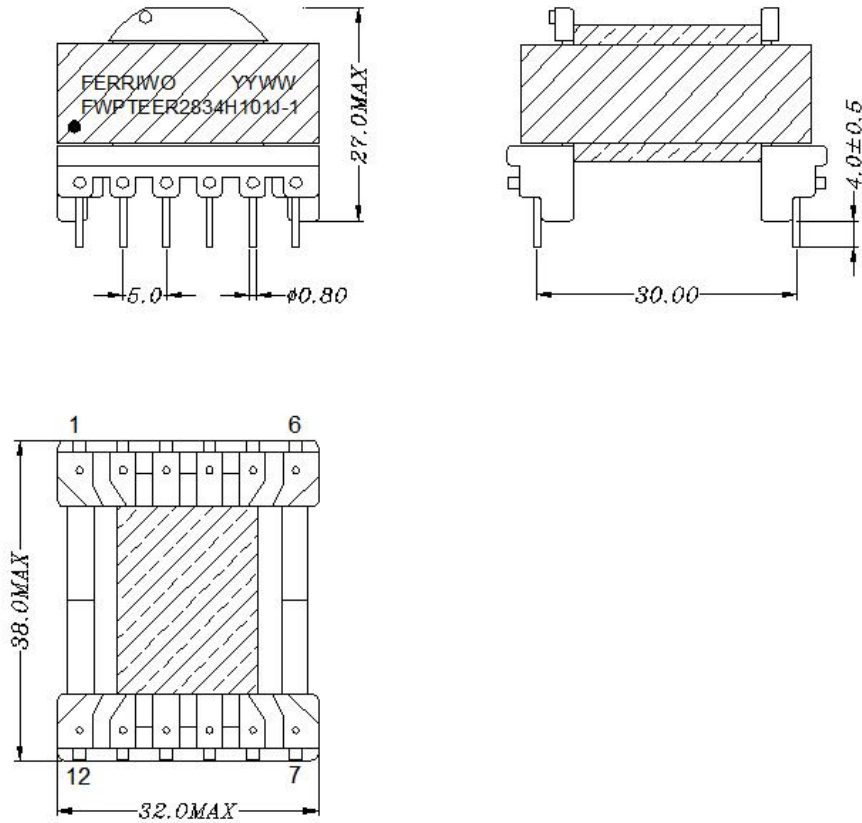

**LEAD FREE**

- \*.Core fix tape 2Ts tape .
- \*.The Label is placed on the product(see the picture above).
- \*.Marked the **PIN #1** by black dot!

DIM	A	B	C	D	E	F	G	H				
SPEC												
						DESCRIPTION		TRANSFORMER				
						Customer P/N		EER2834-170-700				
						FERRIWO P/N		FWPTEER2834H101J-1				
SPEC. NO.	PS-2023-038				PREPARED			APPROVED				

# SPECIFICATION

## 2. SCHEMATIC DIAGRAM:

## 3. CROSS SECTION:

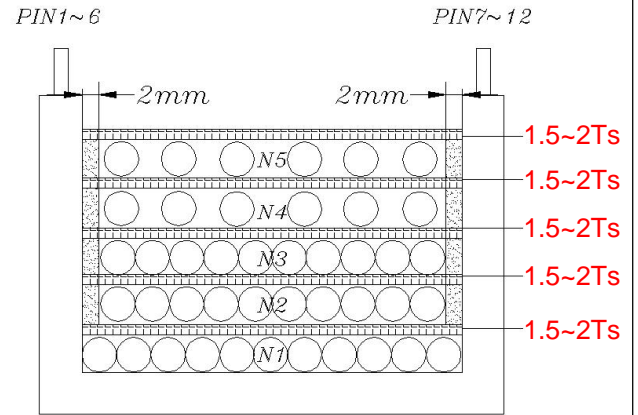
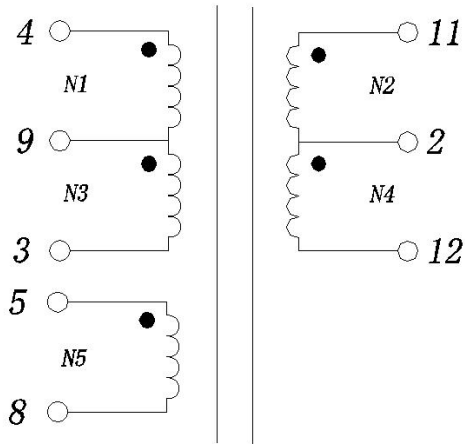

## 4. WINDING TABLE:

Winding NO.	Margin Tape	PIN	Wire & Wire Copper	Turns	Winding Type	Tape Layer	Tube
N1		4-9	0.1 $\phi$ x20P	25Ts	CLOSE	1.5~2Ts	
N2		11-2	0.1 $\phi$ x32P	21Ts	CLOSE	1.5~2Ts	
N3		9-3	0.1 $\phi$ x20P	17Ts	CLOSE	1.5~2Ts	
N4		2-12	0.1 $\phi$ x32P	15Ts	SPREAD	1.5~2Ts	
N5		5-8	0.35 $\phi$ x1P	5Ts	SPREAD	1.5~2Ts	

### NOTE:

- 1. Products should be vacuum varnish.
  - \*VARNISH RATIO:1:2
  - \*VACUUM TIME:15~20minutes
  - \*BAKED TEMPERATURE:120°C±10°C,1~1.5huors

**LEAD FREE**



DESCRIPTION	TRANSFORMER
Customer P/N	EER2834-170-700
FERRIWO P/N	FWPTEER2834H101J-1

SPEC. NO.	PS-2023-038	PREPARED		APPROVED	
-----------	-------------	----------	--	----------	--

# SPECIFICATION

## 5. ELECTRONICAL CHARACTERISTIC:

TEST CONDITION : TEMPERATURE AT 25°C  
HUMIDITY AT 65 ±5% RH

TEST ITEM	TEST CONDITION	RESULT
INDUCTANCE CH-3250	@1KHz,0.3V (4~9)	100uH±5%
LEAKAGE INDUCTANCE CH-3250	@1KHz,0.3V (4~3)	5.2μH MAX SHORT PIN 11,12
HI-POT TEST CH-9052	@ 2mA 3SEC (AC)	N1,N3,N5<->N2,N4 1.5 KV; N1,N3<->N5 1.0 KV;

NOMINAL RATED POWER - 60 VA

**LEAD FREE**



DESCRIPTION

TRANSFORMER

Customer P/N

EER2834-170-700

FERRIWO P/N

FWPTEER2834H101J-1

SPEC. NO.

PS-2023-038

PREPARED



APPROVED



# SPECIFICATION

## 6. MATERIAL LIST :

ITEM	MATERIAL	SUPPLIER OR MANUFACTURER	TEMPRATING	
1	CORE EER28/34/11	FW95 OR EQUIVALENT	HAINING FERRIWO ELECTRONICS CO., LTD.	
2	BOBBIN EER28 (6+6)	PHENOLIC OR EQUIVALENT	CHANG CHUN PLASTICS CO., LTD. UL NO E59481	150°C
3	WIRE	2UEW-F	PACIFIC ELECTRIC WIRE&CABLE(SHENZHEN) CO. LTD UL NO E84081	155°C
4	TAPE	CT280	YAHUA STICKING TAPE CO.,LTD UL NO E165111	130°C
5	VARNISH	BC-346A	JOHN C DOLPH CO BC-346A UL NO E317427	130°C
6	FLUX	TF9100	LINAN GUITONG CHEMICAL TECHNICAL CO.,LTD	
7	TIN	Sn99.3Cu0.7	HAINING ZHUCHANG METAL FOIL CO;LTD	

**LEAD FREE**



DESCRIPTION

TRANSFORMER

Customer P/N

EER2834-170-700

FERRIWO P/N

FWPTEER2834H101J-1

SPEC. NO.

PS-2023-038

PREPARED



APPROVED

