





A PASSION FOR
LIGHTING TECHNOLOGY



SPECIFICATION FOR APPROVAL

DESCRIPTION: CURRENT TRANSFORMER
SPECIFICATION: CT323-100
PART NO: FWPTEE5.0SMD100NL
ISSUE DATE: November 15, 2023

MANUFACTURER APPROVAL		
PREPARED	CHECKED	APPROVED
		

CUSTOMER APPROVAL		
PREPARED	CHECKED	APPROVED

Haining Ferriwo Electronics Co.,Ltd.

Address:Block 13, Caohejing Technology Park, No.8,
Haining Avenue, Haining, Zhejiang 314400, China

TEL:+86-0573-87088701 FAX:+86-0573-87081130

www.ferriwo.com sales@ferriwo.com

SPECIFICATION

1. PHYSICAL DIMENSION(UNIT: m/m):

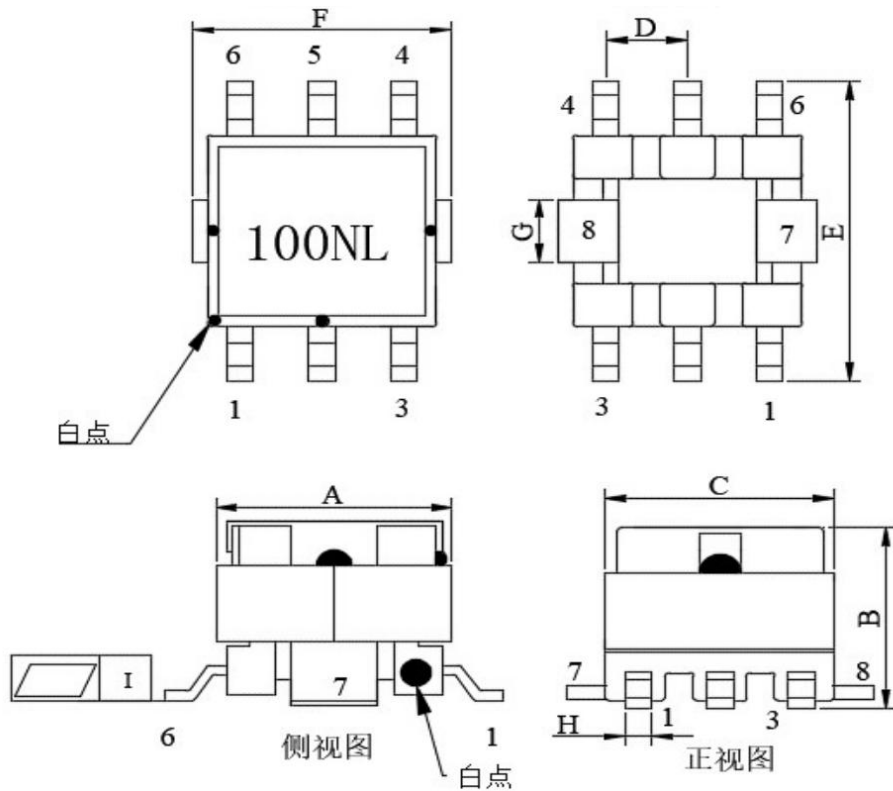

LEAD FREE

*.The Label is placed on the product(see the picture above).

DIM	A	B	C	D	E	F	G	H	I			
	MAX	MAX	MAX	±0.2	±0.3	MAX	±0.1	±0.1	MAX			
SPEC	6.0	5.5	6.5	1.85	7.7	7.5	2.0	0.6	0.13			

 <p>A PASSION FOR LIGHTING TECHNOLOGY</p>	DESCRIPTION	CURRENT TRANSFORMER
	Customer P/N	CT323-100
	FERRIWO P/N	FWPTEE5.0SMD100NL

SPEC. NO.	PS-2023-089	PREPARED		APPROVED	
-----------	-------------	----------	--	----------	---

2.WINDING TABLE:

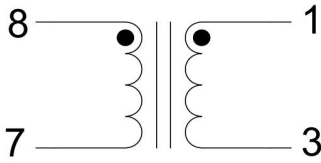

3.WINDING TABLE:

Winding NO.	Margin Tape	PIN	Wire & Wire Copper	Turns	Winding Type	Tape Layer	Tube
N1		1~3	0.08 ϕ x 1P	100Ts	CLOSE	2Ts	
N2		8~7	U-shaped iron buckle	1Ts			

4.ELECTRONICAL CHARACTERISTIC:



TEST CONDITION : TEMPERATURE AT 25°C
HUMIDITY AT 65 ±5% RH

TEST ITEM	TEST CONDITION	RESULT
INDUCTANCE CH-3250	@20.0KHz,1V (1~3)	2.0mH MIN
DCR CH-502	(1~3)	5.36ΩMAX
HI-POT TEST CH-9052	@ 5mA 3SEC (AC)	Pri<->Sec 500V;

NOMINAL RATED POWER - 10 VA

LEAD FREE

 <p>A PASSION FOR LIGHTING TECHNOLOGY</p>	DESCRIPTION	CURRENT TRANSFORMER
	Customer P/N	CT323-100
	FERRIWO P/N	FWPTEE5.0SMD100NL

SPEC. NO.	PS-2023-089	PREPARED		APPROVED	
-----------	-------------	----------	---	----------	---

SPECIFICATION

5. MATERIAL LIST :

ITEM		MATERIAL	SUPPLIER OR MANUFACTURER	TEMPRATING
1	CORE	FW40 OR EQUIVALENT	HAINING FERRIWO ELECTRONICS CO., LTD.	
2	BOBBIN EE5(3+3)	PHENOLIC OR EQUIVALENT	SUMITOMO BAKELITE CO., LTD. UL NO E41429	150°C
3	WIRE	1UEW-F	PACIFIC ELECTRIC WIRE&CABLE(SHENZHEN) CO. LTD UL NO E84081	155°C
4	CLIP	C-144-1	PIN SHINE INDUSTRIAL CO.,LTD	
5	TAPE	CT280	YAHUA STICKING TAPE CO.,LTD UL NO E165111	130°C
6	FLUX	TF9100	LINAN GUITONG CHEMICAL TECHNICAL CO.,LTD	
7	TIN	Sn99.3Cu0.7	HAINING ZHUCHANG METAL FOIL CO;LTD	

LEAD FREE



A PASSION FOR
LIGHTING TECHNOLOGY

DESCRIPTION	CURRENT TRANSFORMER
Customer P/N	CT323-100
FERRIWO P/N	FWPTEE5.0SMD100NL

SPEC. NO.

PS-2023-089

PREPARED



APPROVED



6. REFLOW TEMPERATURE:

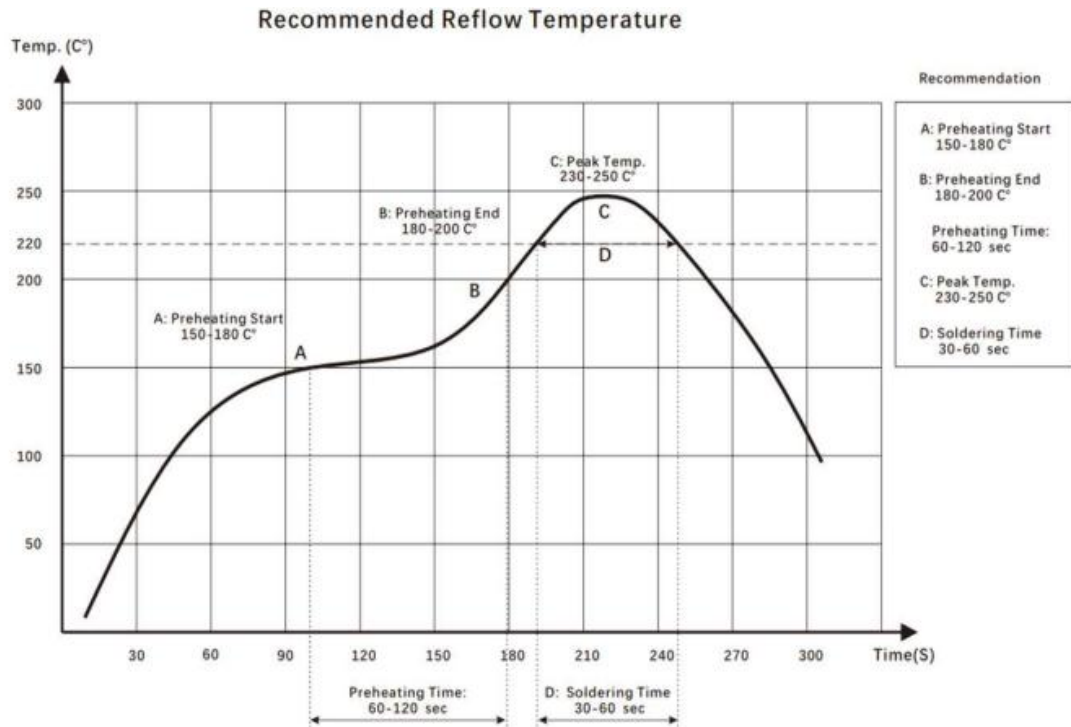

step#	Profile Feature	Condition/Duration
step1	Ramp-up rate	1.5-3°C/sec
step2	Preheat : 150~180°C(A-B)	60~120 sec.
step3	Ramp-up rate(B to C)	1.5-3°C/sec.
	Temperature maintained above 200°C@	30±10sec.
step4	Peak temperature(C)	230°C-250°C
	Time within 5°C of actual peak temperature	30-60 sec.
step5	Ramp-down rate	6°C/sec.Max
Note1	Subject the samples to the cycles of the above define reflow conditions	
Note2	Time 25°C to peak temperature : 6 minutes max.	
Note3	The time between reflows shall be 5 minutes minimum and 60minutes maximum	

LEAD FREE

A PASSION FOR LIGHTING TECHNOLOGY	DESCRIPTION	CURRENT TRANSFORMER			
	Customer P/N	CT323-100			
	FERRIWO P/N	FWPTEE5.0SMD100NL			
SPEC. NO.	PS-2023-089	PREPARED		APPROVED	

7.PACKING:

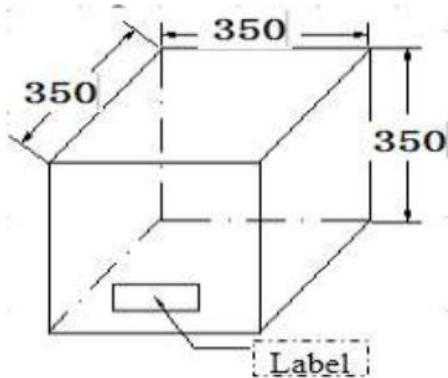

Item	Data
Reel	13"
Reel Width	19.5mm
Length of Carry Tape	12.4m/reel
Quantity Per Reel	1000 pcs/reel
Diameter of Reel Axis	100mm
Carry Tape	PS ESD
Cover Tape	PE
In Box Quantity	15 reels
MPQ	15000 pcs
Packing Box Size	350*350*350mm

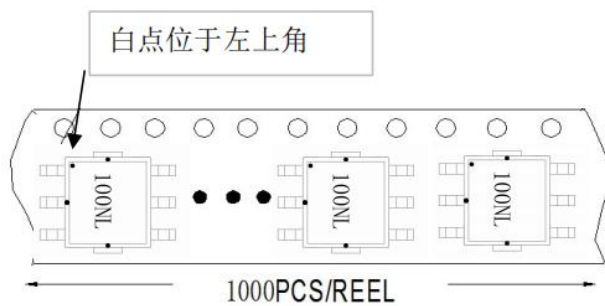

LEAD FREE



A PASSION FOR
LIGHTING TECHNOLOGY

DESCRIPTION	CURRENT TRANSFORMER
Customer P/N	CT323-100
FERRIWO P/N	FWPTEE5.0SMD100NL

SPEC. NO.

PS-2023-089

PREPARED



APPROVED

