

SPECIFICATION

1. PHYSICAL DIMENSION(UNIT: m/m):

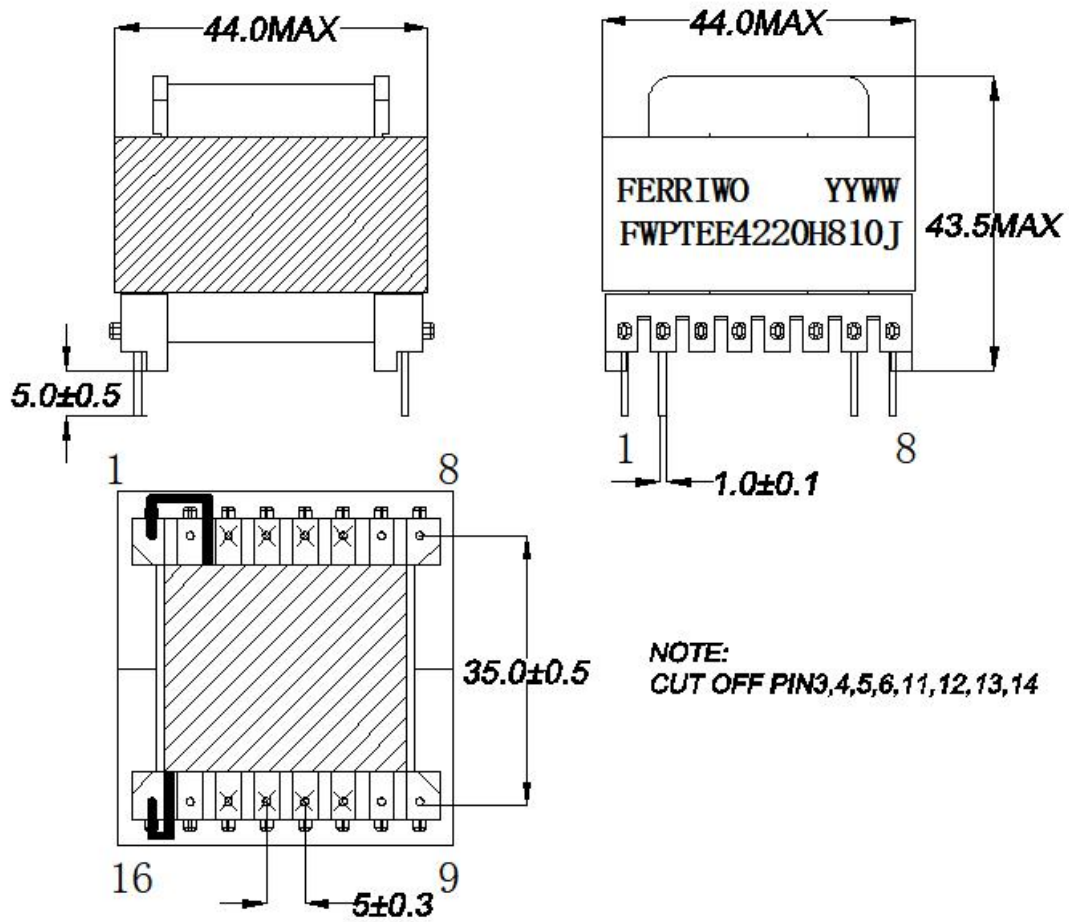

*.Core fix tape 3Ts .

*.The Label is placed on the product(see the picture above).

LEAD FREE

DIM	A	B	C	D	E	F	G	H				
SPEC												

	DESCRIPTION	CHOKE
	Customer P/N	EE4220
	FERRIWO P/N	FWPTEE4220H810J

SPEC. NO.	PS-2023-020	PREPARED		APPROVED	
-----------	-------------	----------	--	----------	--

SPECIFICATION

2.WINDING TABLE:

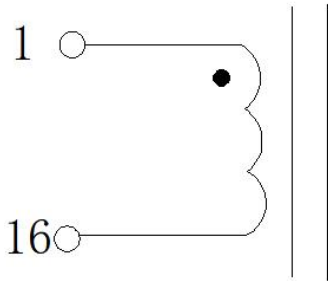

3.WINDING:

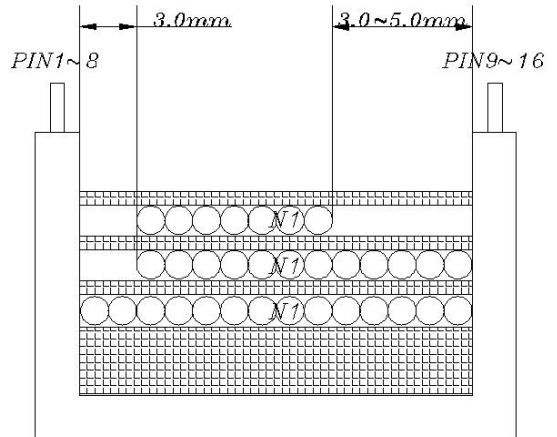

Note: Use margin tape 9 turns with 0.3t*27.0mm around the bobbin before winding

4.WINDING TABLE:

Winding NO.	Margin Tape	PIN	Wire & Wire Copper	Turns	Winding Type	Tape Layer	Tube
N2		1~16	USTC-0.07 ϕ x 250P	33Ts (14+12+7)	CLOSE	2Ts+2Ts+2Ts	

NOTE:

- 1. Products should be vacuum impregnation
- *VARNISH RATIO: 1:1
- *VACUUM TIME: 15~20minutes
- *BAKED TEMPERATURE : 120°C±10°C, 1~1.5hours

LEAD FREE

	DESCRIPTION	CHOKE			
	Customer P/N	EE4220			
	FERRIWO P/N	FWPTEE4220H810J			
SPEC. NO.	PS-2023-020	PREPARED		APPROVED	

SPECIFICATION

5. ELECTRONICAL CHARACTERISTIC:

TEST CONDITION : TEMPERATURE AT 25°C

HUMIDITY AT 65 ±5% RH

TEST ITEM	TEST CONDITION	RESULT
INDUCTANCE CH-3250	@1KHz,0.3V (1~16)	81uH±5%

LEAD FREE

DESCRIPTION

CHOKE

Customer P/N

EE4220

FERRIWO P/N

FWPTEE4220H810J

SPEC. NO.

PS-2023-020

PREPARED



APPROVED



SPECIFICATION

6. MATERIAL LIST :

ITEM	MATERIAL	SUPPLIER OR MANUFACTURER	TEMPRATING
1	CORE EE4220	FW44 OR EQUIVALENT HAINING FERRIWO ELECTRONICS CO., LTD.	
2	BOBBIN FWB4220-Z	PHENOLIC OR EQUIVALENT SUMITOMO BAKELITE CO., LTD. UL NO E41429	150°C
3	WIRE	2UEW-F PACIFIC ELECTRIC WIRE&CABLE(SHENZHEN) CO. LTD UL NO E84081	155°C
4	TAPE	CT280 YAHUA STICKING TAPE CO.,LTD UL NO E165111	130°C
5	VARNISH	R-1038 JOHN C DOLPH CO BC-346A UL NO E317427	130°C
6	FLUX	TF9100 LINAN GUITONG CHEMICAL TECHNICAL CO.,LTD	
7	TIN	Sn99.3Cu0.7 HAINING ZHUCHANG METAL FOIL CO;LTD	

LEAD FREE



DESCRIPTION

CHOKE

Customer P/N

EE4220

FERRIWO P/N

FWPTEE4220H810J

SPEC. NO.

PS-2023-020

PREPARED



APPROVED

