





A PASSION FOR
LIGHTING TECHNOLOGY



SPECIFICATION FOR APPROVAL

DESCRIPTION: Transformer
 SPECIFICATION: EE4215
 PART NO: FWPTEE42H111J-1
 ISSUE DATE: June 6, 2024

| MANUFACTURER APPROVAL | | |
|--|--|---|
| PREPARED | CHECKED | APPROVED |
|  工程部 2023. 11. 24 夏晓凯 |  工程部 2023. 11. 24 潘玉财 |  工程部 2023. 11. 24 俞涛 |

| CUSTOMER APPROVAL | | |
|-------------------|---------|----------|
| PREPARED | CHECKED | APPROVED |
| | | |

| FOSO POWER TECHNOLOGY CO., LTD. | |
|--|-----------------------|
| Address: Block 13, Caohejing Technology Park, No.8, Haining Avenue, Haining, Zhejiang 314400, China | |
| TEL:+86-573-8787-3600 | FAX:+86-0573-87081130 |
| www.fosopower.com | contact@fosopower.com |

SPECIFICATION

1. PHYSICAL DIMENSION(UNIT: m/m):

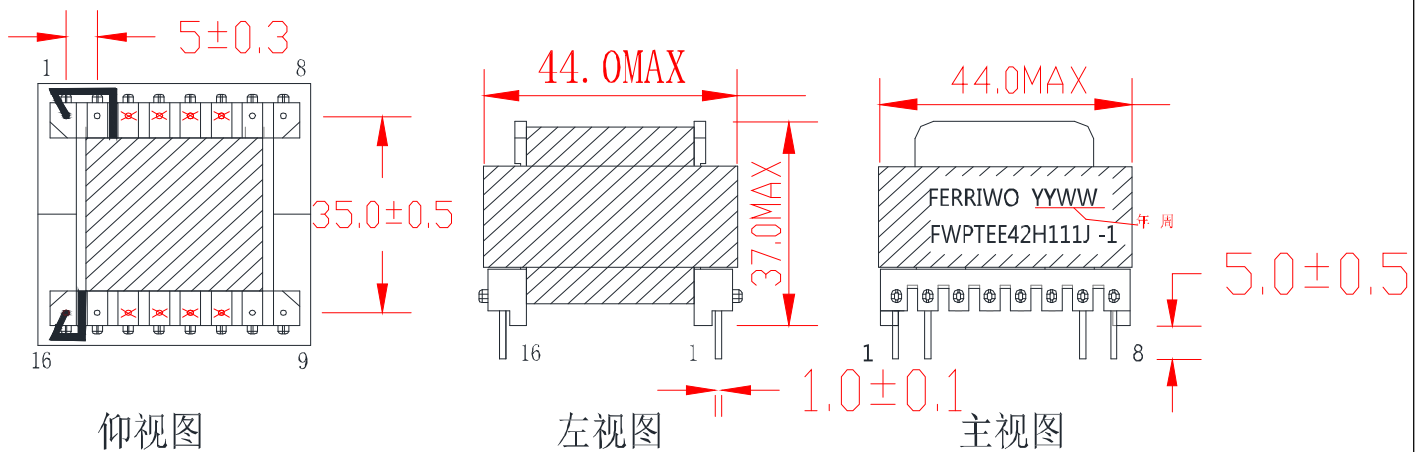

NOTE:

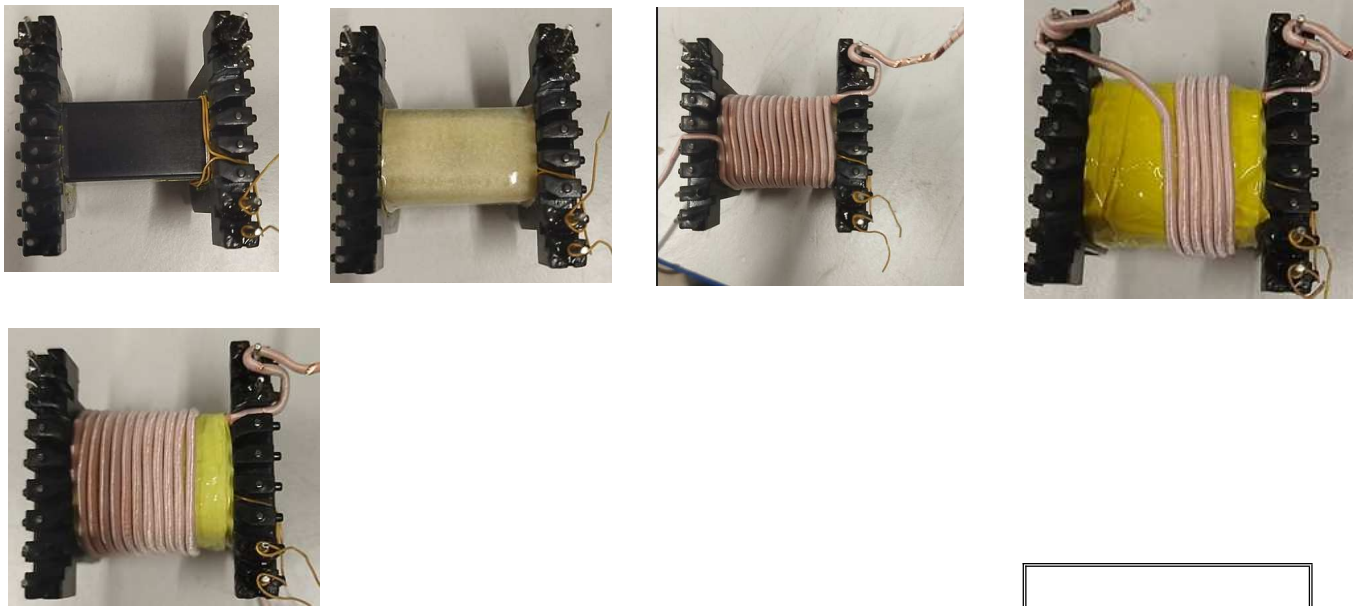

CUT OFF PIN3,4,5,6,11,12,13,14.



LEAD FREE

*.Core fix tape 3Ts .

*.The Label is placed on the product(see the picture above).

| DIM | A | B | C | D | E | F | G | H | | | | |
|--|-------------|---|---|---|----------|--|---|-----------------|---|--|--|--|
| SPEC | | | | | | | | | | | | |
|  A PASSION FOR LIGHTING TECHNOLOGY | | | | | | DESCRIPTION | | Transformer | | | | |
| | | | | | | Customer P/N | | EE4215 | | | | |
| | | | | | | FERRIWO P/N | | FWPTEE42H111J-1 | | | | |
| SPEC. NO. | PS-2023-092 | | | | PREPARED |  | | APPROVED |  | | | |

SPECIFICATION

2.WINDING TABLE:

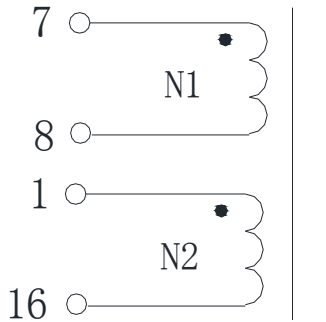

3.WINDING:

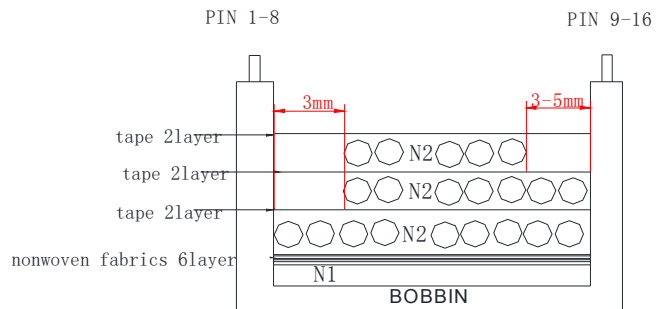



4.WINDING TABLE:

| winding | 起末端 | | | | wire | | | Turn (TS) | Tape | winding way |
|---|-------|--------|-----|--------|-----------------------------|----|----|---------------|------------------|-------------|
| | start | groove | end | groove | | 开始 | 结束 | | | |
| N1 | 7 | 5 | 8 | 5 | TIW-B ϕ 0.20mm | / | / | 2 | / | |
| nonwoven fabrics T0.28mm*27.0mm 6 turns | | | | | | | | | | |
| N2 | 1 | 2 | 16 | 14 | USTC QA-1 ϕ 0.07mm*250 | / | / | 14+12+7 turns | 0.025*27.0mm*2TS | Close |
| Wrap tape along the direction of the core | | | | | | | | | 0.025*15mm*3TS | |

NOTE:

- Products should be vacuum impregnation
- *VARNISH RATIO: 1:1
- *VACUUM TIME: 15~20minutes
- *BAKED TEMPERATURE : 120°C±10°C, 1~1.5hours

LEAD FREE

| | | | | | |
|--|--------------|-----------------|---|----------|---|
|  <p>A PASSION FOR LIGHTING TECHNOLOGY</p> | DESCRIPTION | Transformer | | | |
| | Customer P/N | EE4215 | | | |
| | FERRIWO P/N | FWPTEE42H111J-1 | | | |
| SPEC. NO. | PS-2023-092 | PREPARED |  | APPROVED |  |

5. ELECTRONICAL CHARACTERISTIC:

TEST CONDITION : TEMPERATURE AT 25°C
HUMIDITY AT 65 ±5% RH

| TEST ITEM | TEST CONDITION | RESULT |
|-----------------------|----------------------|----------|
| INDUCTANCE CH-3250 | @1KHz,0.3V (1~16) | 110uH±5% |

NOMINAL RATED POWER - 200 VA

6. Note:

- ①:Winding direction is winding clockwise rotation
- ②:Bobbin insertion fixture direction is shown below:

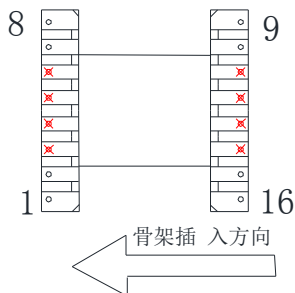

LEAD FREE

| | | | | | |
|-----------|--------------------------------------|--------------|-----------------|----------|--|
| | A PASSION FOR LIGHTING TECHNOLOGY | DESCRIPTION | Transformer | | |
| | | Customer P/N | EE4215 | | |
| | | FERRIWO P/N | FWPTEE42H111J-1 | | |
| SPEC. NO. | PS-2023-092 | PREPARED | | APPROVED | |

SPECIFICATION

6. MATERIAL LIST :

| ITEM | MATERIAL | SUPPLIER OR MANUFACTURER | TEMPRATING |
|------|--|---|------------|
| 1 | CORE EE42/42/15 FW44 OR EQUIVALENT | HAINING FERRIWO ELECTRONICS CO., LTD. | |
| 2 | BOBBIN FWB4201-Q PHENOLIC OR EQUIVALENT | SUMITOMO BAKELITE CO., LTD. UL NO E41429 | 150°C |
| 3 | Slik wire USTCQA-1φ0.07mm*250 | PACIFIC ELECTRIC WIRE&CABLE(SHENZHEN) CO. LTD UL NO E84081 | 155°C |
| 4 | TAPE CT280 | YAHUA STICKING TAPE CO.,LTD UL NO E165111 | 130°C |
| 5 | VARNISH R-1038 | JOHN C DOLPH CO BC-346A UL NO E317427 | 130°C |
| 6 | FLUX TF9100 | LINAN GUITONG CHEMICAL TECHNICAL CO.,LTD | |
| 7 | TIN Sn99.3Cu0.7 | HAINING ZHUCHANG METAL FOIL CO;LTD | |
| 8 | TIW TIW-Bφ0.20m | HAINING ZHUCHANG METAL FOIL CO;LTD | |

LEAD FREE



A PASSION FOR
LIGHTING TECHNOLOGY

DESCRIPTION

Transformer

Customer P/N

EE4215

FERRIWO P/N

FWPTEE42H111J-1

SPEC. NO.

PS-2023-092

PREPARED



APPROVED

