



SPECIFICATION FOR APPROVAL

DESCRIPTION : INDUCTOR
 SPECIFICATION : EF12.6-510uH
 PART NO. : FWIEF12.6V511K
 ISSUE DATE : 26 November 2021

MANUFACTURER APPROVAL		
PREPARED	CHECKED	APPROVED
工程部 夏晓凯 2021.11.26	工程部 潘玉财 2021.11.26	工程部 王永生 2021.11.26

CUSTOMER APPROVAL		
RECEIPT	CHECKED	APPROVED

Haining Ferriwo Electronics Co., Ltd.	
Address:Block 13, Caohejing Technology Park, No.8, Haining Avenue, Haining, Zhejiang , China	
TEL: +86-573-87088701	FAX: +86+573-87081130
www.ferriwo.com	sales@ferriwo.com

SPECIFICATION

1. PHYSICAL DIMENSION(UNIT: m/m):

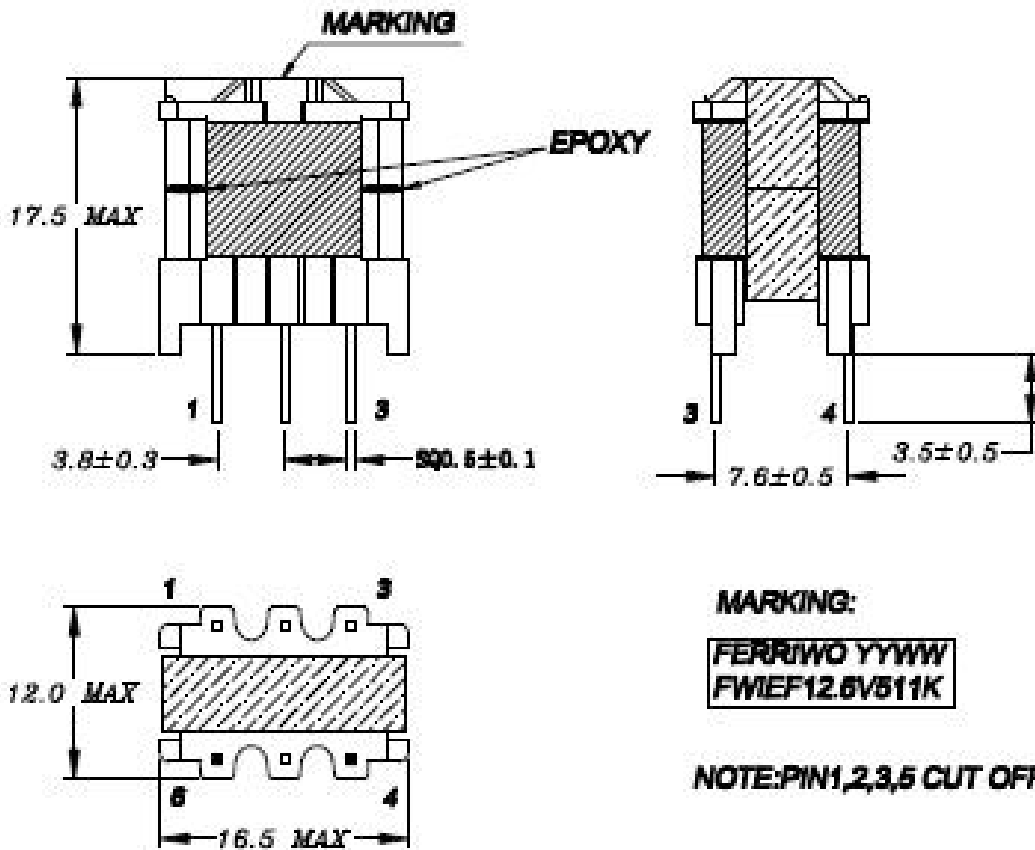

*.Core fix tape 2Ts tape .

*.The Marking is placed on the product(see the picture above).

LEAD FREE

DIM	a	b	c	d	e	f	g						
SPEC													
							DESCRIPTION		INDUCTOR				
							Customer P/N		EF12.6-510uH				
							FERRIWO P/N		FWIEF12.6V511K				
SPEC. NO.	PS-2021-087				PREPARED	夏晓凯 2021.11.26		APPROVED	王永生 2021.11.26				

SPECIFICATION

2.WINDING TABLE:

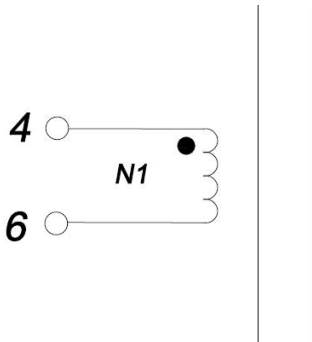

3.CROSS SECTION:

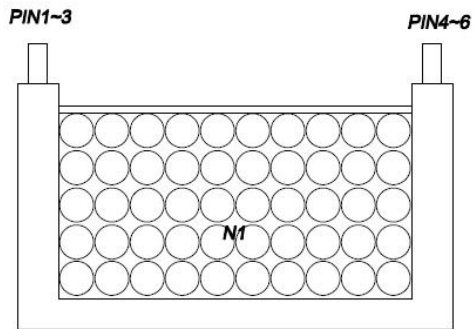

4.WINDING TABLE:

Winding NO.	Margin Tape	PIN	Wire &Wire Copper	Turns	Winding Type	Tape Layer	Tube
N1	0	4~6	0.10 ϕ x 10P (LITZ)	84Ts	CLOSE	2Ts	

NOTE:

- Products should be vacuum varnish.
 *VARNISH RATIO:1:2
 *VACUUM TIME:15~20minutes
 *BAKED TEMPERATURE:120°C±10°C,1~1.5huors

LEAD FREE

DESCRIPTION	INDUCTOR
Customer P/N	EF12.6-510uH
FERRIWO P/N	FWIEF12.6V511K

SPEC. NO.	PS-2021-087	PREPARED	夏晓凯 2021.11.26	APPROVED	王永生 2021.11.26
-----------	-------------	----------	-------------------	----------	-------------------

SPECIFICATION

4/5

5. ELECTRONICAL CHARACTERISTIC:

TEST CONDITION : TEMPERATURE AT 25°C

HUMIDITY AT 65 ±5% RH

TEST ITEM	TEST CONDITION	RESULT
INDUCTANCE CH-3250	@15KHz,1V (4~6)	510uH ± 10%

LEAD FREE



DESCRIPTION

INDUCTOR

Customer P/N

EF12.6-510uH

FERRIWO P/N

FWIEF12.6V511K

SPEC. NO.

PS-2021-087

PREPARED

夏晓凯
2021.11.26

APPROVED

王永生
2021.11.26

SPECIFICATION

6. MATERIAL LIST :

ITEM	MATERIAL	SUPPLIER OR MANUFACTURER	TEMPRATING	
1	CORE EE13/7/4	FW40 OR EQUIVALENT	HAINING FERRIWO ELECTRONICS CO., LTD.	
2	BOBBIN FWB1201	PLASTIC OR EQUIVALENT	EIDUPONT DE NEMOURS&COINC UL NO E69578	150℃
3	WIRE	2UEW-F	PACIFIC ELECTRIC WIRE&CABLE(SHENZHEN) CO. LTD UL NO E84081	155℃
4	EPOXY	E-500 (BLACK)	SUZHOU EATTO ELECTRONIC MATERIAL CO.,LTD UL NO E218090	130℃
5	VARNISH	BC-346A	JOHN C DOLPH CO BC-346A UL NO E317427	130℃
6	FLUX	TF9100	LINAN GUITONG CHEMICAL TECHNICAL CO.,LTD	
7	TIN	Sn99.3Cu0.7	HAINING ZHUCHANG METAL FOIL CO;LTD	

LEAD FREE



DESCRIPTION

INDUCTOR

Customer P/N

EF12.6-510uH

FERRIWO P/N

FWIEF12.6V511K

SPEC. NO.

PS-2021-087

PREPARED

夏晓凯
2021.11.26

APPROVED

王永生
202111.26