





A PASSION FOR
LIGHTING TECHNOLOGY



SPECIFICATION FOR APPROVAL

DESCRIPTION: Inductor
 SPECIFICATION: DRI0810-1.0mH
 PART NO.: FSDRI0810T102KL(Mgzn)
 ISSUE DATE: January 19, 2024

MANUFACTURER APPROVAL		
PREPARED	CHECKED	APPROVED
		

CUSTOMER APPROVAL		
RECEIPT	CHECKED	APPROVED



Haining Ferriwo Electronics Co., Ltd.	
Address: Block 13, Caohejing Technology Park, No.8, Haining Avenue, Haining, Zhejiang, China	
TEL: +86-573-87088701	FAX: +86+573-87081130
www.ferriwo.com	sales@ferriwo.com

SPECIFICATION

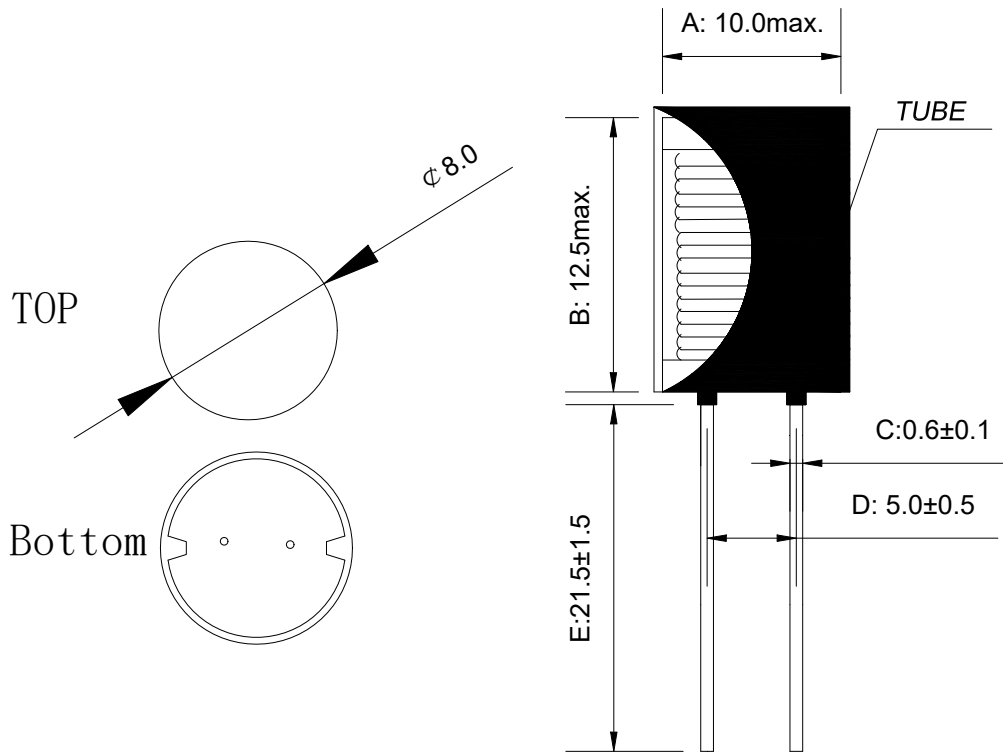
1. PHYSICAL DIMENSION(UNIT: m/m):



LEAD FREE

DIM	A	B	C	D	E	F	G	H				
	SPEC											
 A PASSION FOR LIGHTING TECHNOLOGY						DESCRIPTION			INDUCTOR			
						Customer P/N			DRI0810-1.0mH			
						FERRIWO P/N			FSDRI0810T102KL(Mgzn)			
SPEC. NO.	PS-2024-002				PREPARED			APPROVED				

2. WINDING TABLE:

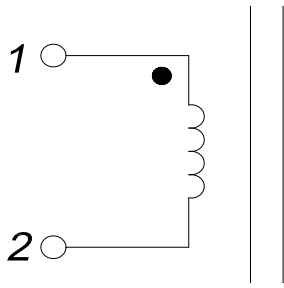

3.WINDING TABLE:

Winding NO.	Margin Tape	PIN	Wire &Wire Copper	Turns	Winding Type	Tape Layer	Tube
N1		1~2	0.23 ϕ x 1P	171Ts±10Ts	CLOSE		

LEAD FREE



A PASSION FOR
LIGHTING TECHNOLOGY

DESCRIPTION	INDUCTOR
Customer P/N	DRI0810-1.0mH
FERRIWO P/N	FSDRI0810T102KL(Mgzn)

SPEC. NO.	PS-2024-002	PREPARED		APPROVED	
-----------	-------------	----------	--	----------	--



SPECIFICATION

4. ELECTRONICAL CHARACTERISTIC:

TEST CONDITION : TEMPERATURE AT 25°C
HUMIDITY AT 65 ±5% RH

TEST ITEM	TEST CONDITION	RESULT
INDUCTANCE CH-3250	@1KHz,0.3V (1~2)	1.0mH±10%
DCR CH-502	(1~2)	3.0Ω MAX

LEAD FREE

 A PASSION FOR LIGHTING TECHNOLOGY	DESCRIPTION	INDUCTOR			
	Customer P/N	DRI0810-1.0mH			
	FERRIWO P/N	FSDRI0810T102KL(Mgzn)			
SPEC. NO.	PS-2024-002	PREPARED		APPROVED	

SPECIFICATION

5. MATERIAL LIST :

ITEM		MATERIAL	SUPPLIER OR MANUFACTURER	TEMPRATING
1	CORE	DR8*10 (MgZn) OR EQUIVALENT	HAINING FERRIWO ELECTRONICS CO., LTD.	
2	WIRE	2UEW-F	PACIFIC ELECTRIC WIRE&CABLE(SHENZHEN) CO. LTD UL NO E84081	155 °C
3	TUBE	RSFR-H	SHENZHEN WOER HEAT-SHRINKABLE MATERIAL CO LTD UL NO E203950	125 °C
4	TIN	Sn99.3Cu0.7	HAINING ZHUCHANG METAL FOIL CO;LTD	

LEAD FREE



A PASSION FOR
LIGHTING TECHNOLOGY

DESCRIPTION

INDUCTOR

Customer P/N

DRI0810-1.0mH

FERRIWO P/N

FSDRI0810T102KL(Mgzn)

SPEC. NO.

PS-2024-002

PREPARED



APPROVED



6. PACKAGE:

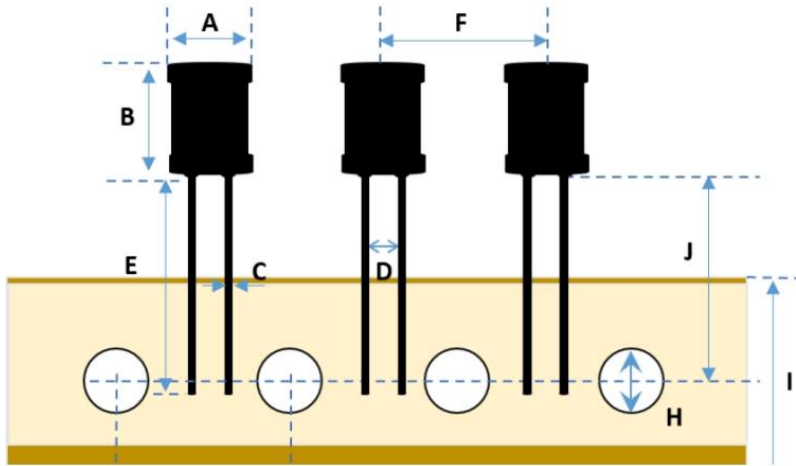

A	10 Max
B	12.5 Max
C	0.6±0.1
D	5±0.5
E	21.5±1.5
F	12.7±0.5
G	12.7±0.5
H	4±0.5
I	18±1
J	19.5±1

LEAD FREE



A PASSION FOR
LIGHTING TECHNOLOGY

DESCRIPTION

INDUCTOR

Customer P/N

DRI0810-1.0mH

FERRIWO P/N

FSDRI0810T102KL(Mgzn)

SPEC. NO.

PS-2024-002

PREPARED



APPROVED

