

1		2		3		4		5		6		7		8	
未注公差/General tolerances(mm)															
>0 ~	>3 ~	>6 ~	>10 ~	>18 ~	>30 ~	>50 ~	>80 ~	>120 ~	>180 ~	>250 ~	>315 ~	>400 ~	>500	0.1/10	
3	6	10	18	30	50	80	120	180	250	315	400	500			
±0.15	±0.20	±0.25	±0.30	±0.35	±0.40	±0.60	±0.80	±0.95	±1.00	±1.20	±1.60	±2.20	±2.50	±2 <sup>c</sup>	

5	6	7	8	
符号/SIGN	描述/DESCRIPTION		修订者/DRAWN	日期/DATE
△0	新版发行		LHJ	2024/10/23

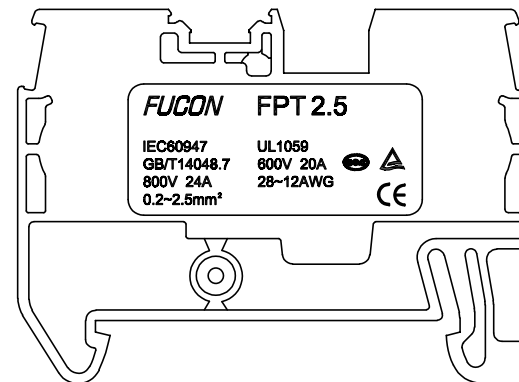
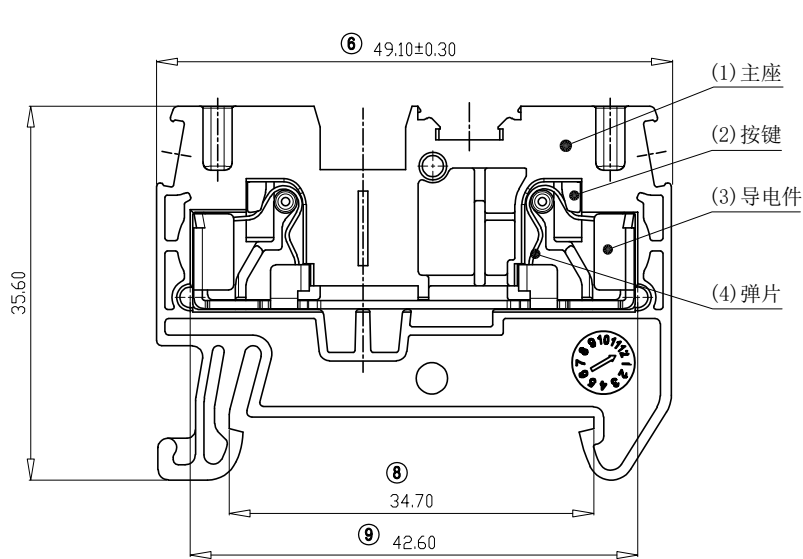
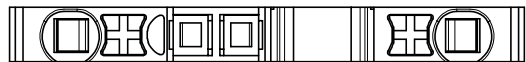

技术参数 Technical parameter:

● 产品标准/ Rated Voltage	UL1059	IEC60947	GB14048
● 获得安规及标志 Access to Safety Mark			
● 证书号码/ Certificate No		R595648920001	CQC22012370390
● 额定电压/ Rated Voltage	600V	800V	800V
● 额定电流/ Rated Current	20A	24A	24A
● 线径范围/ Wire range		0.2-2.5mm <sup>2</sup>	0.2-2.5mm <sup>2</sup>
● 硬质导线/ Solid wire (AWG)	28-12AWG		
● 软质导线/ Stranded wire (AWG)	28-12AWG		
● 剥线长度/ Wire strip length	12mm	12mm	12mm
● 绝缘耐压/ Withstanding Voltage	2200V	3500V	3500V
● 温度范围/ Operating temperature	-40℃~105℃		
● 焊接温度/ Soldering temperature			
● 关键尺寸/ Critical dimension			

ITEM 序号	NAME OF PART 部件名称	Material 材料	NOTES 备注	QTY 用量
④	弹片/Shrapnel	不锈钢/SUS301		2
③	导电件/Conductive parts	紫铜/T2	镀雾锡/Fogged Tin	1
②	按键/button	POM	UL94-HB	2
①	主座/Housing	尼龙/PA66	UL94-V0	1

	CAT NO./认证型号	FPT2.5	SHEET: 1/1
	PATE NO./成品料号	N/A	SCALT: 1:1
	CUST NO./客户料号	N/A	REV: A01
APPROVED/ 审批	何跃雄 2024. 10. 23	MODEL: <b>FPT2.5</b>	
CHECKED/ 核准	陈莺 2024. 10. 23	DRAWING NO./???:FPT2.5-001	
DRAWN/ 制图	廖泓境 2024. 10. 23	TYPE/???CUSTOMER_DRAWING	
	SIZE: A4		