

**SPECIFICATION**

- General Characteristics:**  
1.0mm FPC XFP SMT 180°  
ZIF Single Contact Standard Layout
- Material&Finish:**  
Housing:PA9T(UL94V-0),Ivory  
Slider:PPS(UL94V-0),Black  
Terminal:Phosphor Bronze,Tin Plated Over Nickel  
ME:Brass,Tin Plated Over Nickel
- Electrical Characteristics:**  
Current Rating:0.5 Amp Max.  
Operating Voltage:100V AC Max.  
Dielectric Withstanding Voltage:500V AC RMS  
Contact Resistance:30 Milliohms Max.  
Insulation Resistance:500 Megaohms Min.
- Environmental Characteristics:**  
Operation Temperature:-40°C~+85°C
- RoHS Compliant**

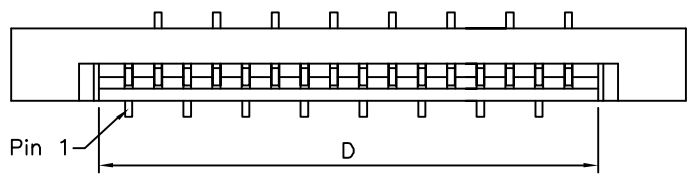

- FPA XX V ZA L - H  
(1) (2) (3) (4) (5) (6)
- (1) FPA:1.0mm FPC/FFC
  - (2) XX:No. Of Position
  - (3) V:SMT Straight
  - (4) ZA:ZIF Single Contact
  - (5) L:Standard Layout
  - (6) H:RoHS Compliant

Pin	A±0.20	B±0.15	C±0.25	D±0.10	E±0.15
4	9.85	3.00	11.00	5.05	3.00
5	10.85	4.00	12.00	6.05	4.00
6	11.85	5.00	13.00	7.05	5.00
7	12.85	6.00	14.00	8.05	6.00
8	13.85	7.00	15.00	9.05	7.00
9	14.85	8.00	16.00	10.05	8.00
10	15.85	9.00	17.00	11.05	9.00
11	16.85	10.00	18.00	12.05	10.00
12	17.85	11.00	19.00	13.05	11.00
13	18.85	12.00	20.00	14.05	12.00
14	19.85	13.00	21.00	15.05	13.00
15	20.85	14.00	22.00	16.05	14.00
16	21.85	15.00	23.00	17.05	15.00
17	22.85	16.00	24.00	18.05	16.00
18	23.85	17.00	25.00	19.05	17.00
19	24.85	18.00	26.00	20.05	18.00
20	25.85	19.00	27.00	21.05	19.00
21	26.85	20.00	28.00	22.05	20.00
22	27.85	21.00	29.00	23.05	21.00
23	28.85	22.00	30.00	24.05	22.00
24	29.85	23.00	31.00	25.05	23.00
25	30.85	24.00	32.00	26.05	24.00
26	31.85	25.00	33.00	27.05	25.00
27	32.85	26.00	34.00	28.05	26.00
28	33.85	27.00	35.00	29.05	27.00
29	34.85	28.00	36.00	30.05	28.00
30	35.85	29.00	37.00	31.05	29.00
31	36.85	30.00	38.00	32.05	30.00
32	37.85	31.00	39.00	33.05	31.00
33	38.85	32.00	40.00	34.05	32.00
34	39.85	33.00	41.00	35.05	33.00

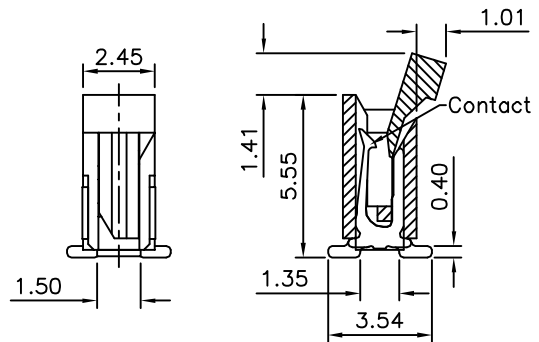
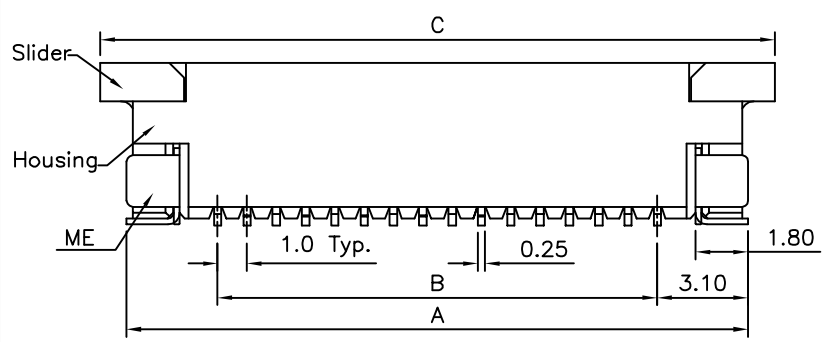

**AUK** A MEMBER OF AUK GROUP  
**太聯事業股份有限公司**  
**AUK CONTRACTORS CO., LTD.**

CATEGORY		APPROVED BY EMILY		UNLESS OTHERWISE SPECIFIED TOLERANCES ARE  .XX ±0.25
PART No. FPAXXVZAL-H		CHECKED BY HZF		
DRAWING No. FPAXXVZAL-H		DRAWING BY SONG		
SCALE NONE	REV.	CO	UNIT mm	

△ CO	NEW RELEASE	HZF	08/15/2014
NO.REV.	REVISIONS	CHK	DATE