

NO	DESCRIPTION	MATERIAL	Q'TY	FINISH	REMARK
1	BODY 1	PBT	1	PBT	B-FKR1348-D44
2	BODY 2	PBT		PBT	B-FKR1308
3	BODY 3	BRASS	1	GOLD	B-FKR1349-N
4	INSULATION 1	TEFLON	1	TEFLON	I-0656T
5	BODY 4	BRASS	1	NICKEL	B-FKR1260-N
6	PIN	BE CU	1	GOLD	P-FKR0970-G
7	WASHER 1	BE CU	1	GOLD	W-0035
8	RING	BRASS	1	GOLD	R-0002-G
9	INSULATION 2	TEFLON	1	TEFLON	I-0136T
10	WASHER 2	BRASS	1	NICKEL	W-0023-N

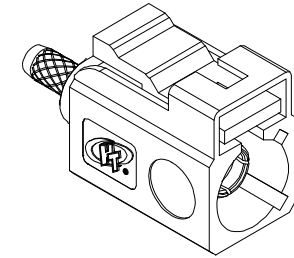

D4004

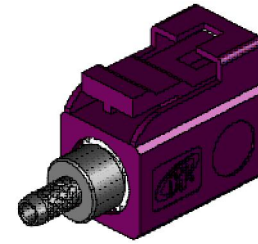
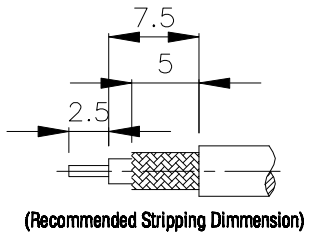
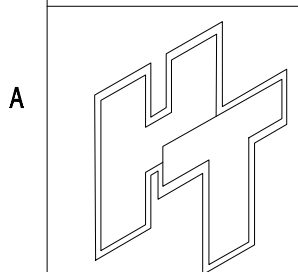
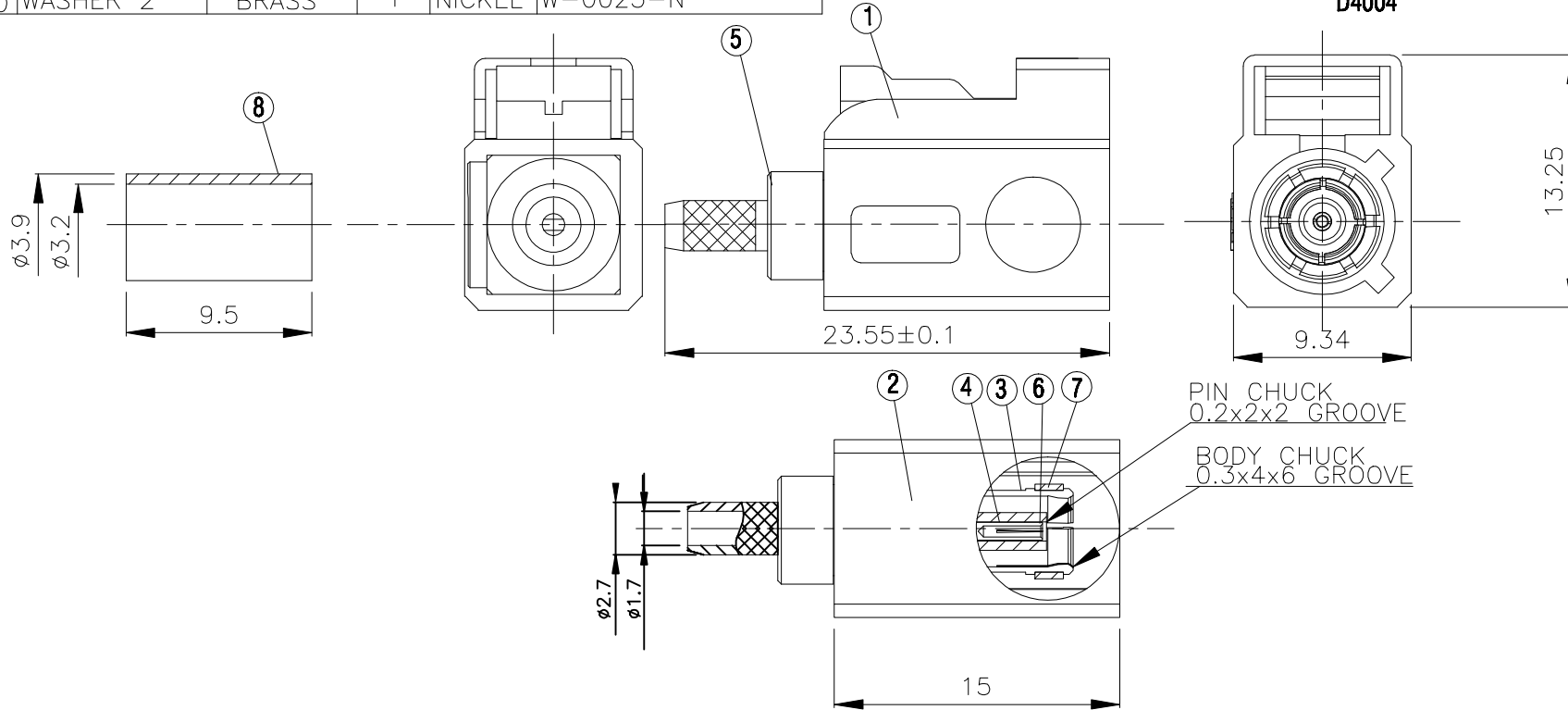

**HUS-TSAN GROUP CO., LTD.**  
P.O.BOX 40-76.TAINAN.TAWAN,R.O.C.  
**TITLE** SMB FEMALE CRIMP FOR RG-174/U,316/U  
**PART NO.** FKR-10LV1-TGNPD  
**DRAWING NO.** FKR 10LV1 TGNPD

**DRAWN** 蘇姿潔 **DATE** 98.05.19  
**CHECKED** 蘇志欣 **DATE**  
**Q.A.** 林妙樺 **DATE**  
**APPROVAL** 徐燦霖 **DATE**  
**REVISION** **DATE**

**DIMENSIONS ARE IN MILLIMETERS**  
**UNLESS OTHERWISE SPECIFIED TOLERANCE**  
0.5-5=±0.2    120-315=±1  
5-30= ±0.4    315-1000=±1.6  
30-120±0.6    1000-2000=±2.4  
**SCALE** 4:1    **SIZE** A

REVISION	
DESCRIPTION	ENGINEER