

NO	DESCRIPTION	MATERIAL	Q'TY	FINISH	REMARK
1	BODY 1	PBT	1	PBT	B-FKR1348-C55
2	BODY 2	PBT		PBT	B-FKR1308
3	BODY 3	BRASS	1	GOLD	B-FKR1349-N
4	INSULATION 1	TEFLON	1	TEFLON	I-0656T
5	BODY 4	BRASS	1	NICKEL	B-FKR1260-N
6	PIN	BE CU	1	GOLD	P-FKR0970-G
7	WASHER 1	BE CU	1	GOLD	W-0035
8	RING	BRASS	1	GOLD	R-0002-G
9	INSULATION 2	TEFLON	1	TEFLON	I-0136T
10	WASHER 2	BRASS	1	NICKEL	W-0023-N

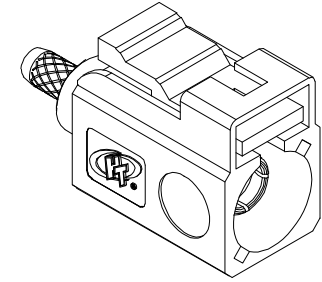

C5005

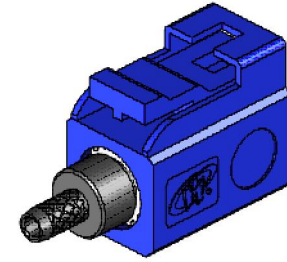
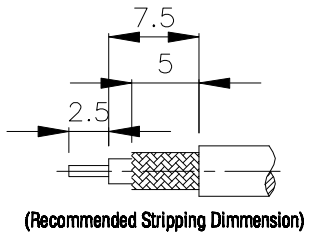
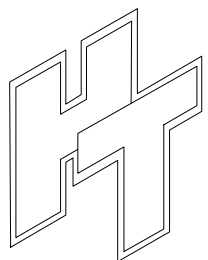
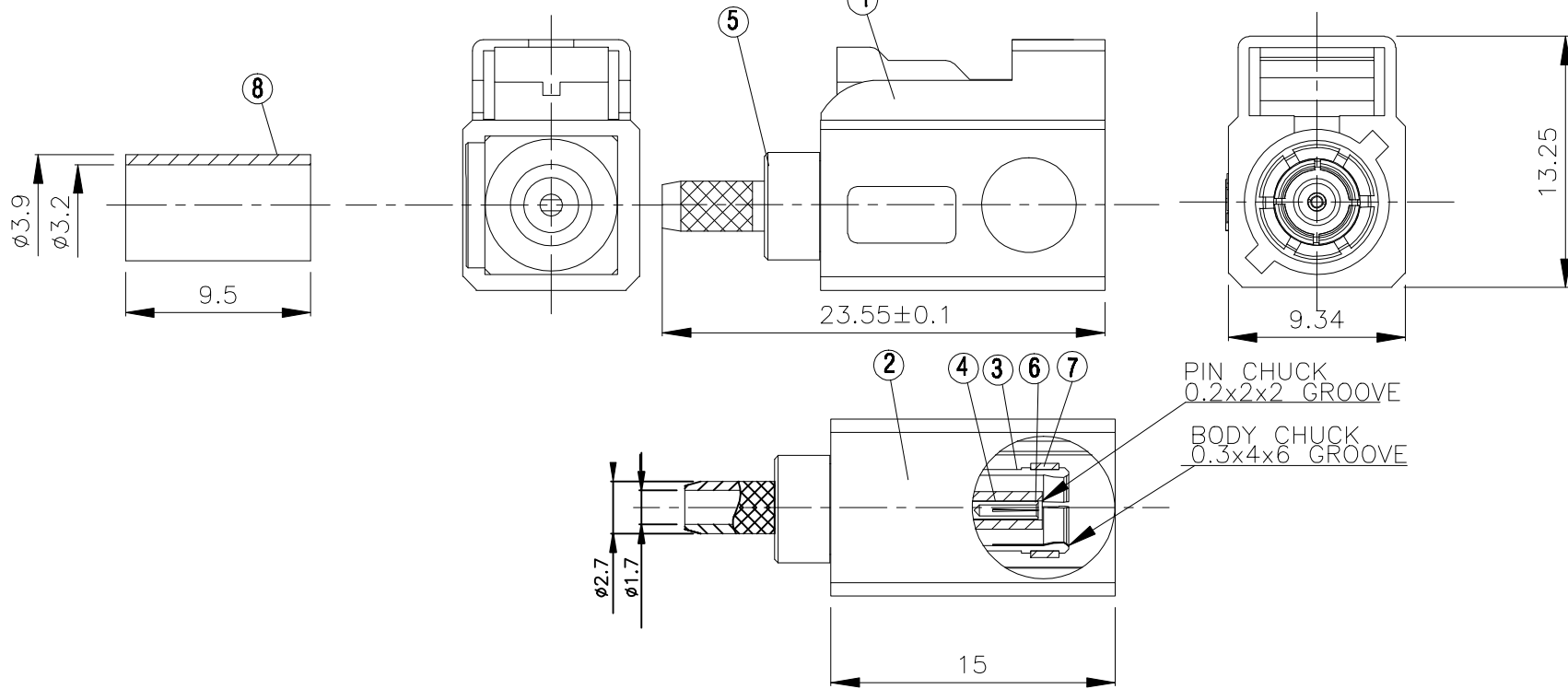

**HUS-TSAN GROUP CO., LTD.**  
P.O.BOX 40-76.TAINAN.TAWAN,R.O.C.

TITLE **SMB FEMALE CRIMP FOR RG-174/U,316/U**

PART NO. **FKR-10LV1-TGNPC**

DRAWING NO. **FKR 10LV1 TGNPC**

DRAWN	蘇姿潔	DATE	98.05.19
CHECKED	蘇志欣	DATE	
Q.A.	林妙樺	DATE	
APPROVAL	徐燦霖	DATE	
REVISION		DATE	

DIMENSIONS ARE IN MILLIMETERS

UNLESS OTHERWISE SPECIFIED TOLERANCE			
0.5-5=±0.2	120-315=±1		
5-30=±0.4	315-1000=±1.6		
30-120±0.6	1000-2000=±2.4		

SCALE 4:1 SIZE A

REVISION	
DESCRIPTION	ENGINEER