

NO	DESCRIPTION	MATERIAL	Q'TY	FINISH	REMARK
1	BODY 1	PBT	1	PBT	B-FKR1348-C55
2	BODY 2	PBT		PBT	B-FKR1308
3	BODY 3	BRASS	1	GOLD	B-FKR1349-N
4	INSULATION 1	TEFLON	1	TEFLON	I-0663T
5	BODY 4	BRASS	1	NICKEL	B-FKR1410-N
6	PIN	BE CU	1	GOLD	P-FKR0986-G
7	WASHER 1	BE CU	1	GOLD	W-0035-G
8	RING	BRASS	1	GOLD	R-0007-G

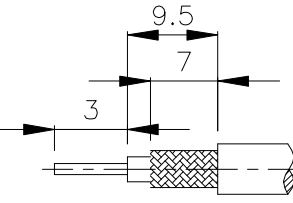

(Recommended Stripping Dimension)

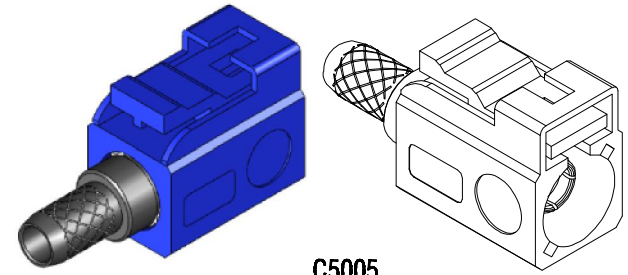

C5005

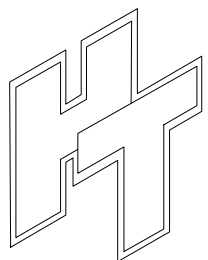
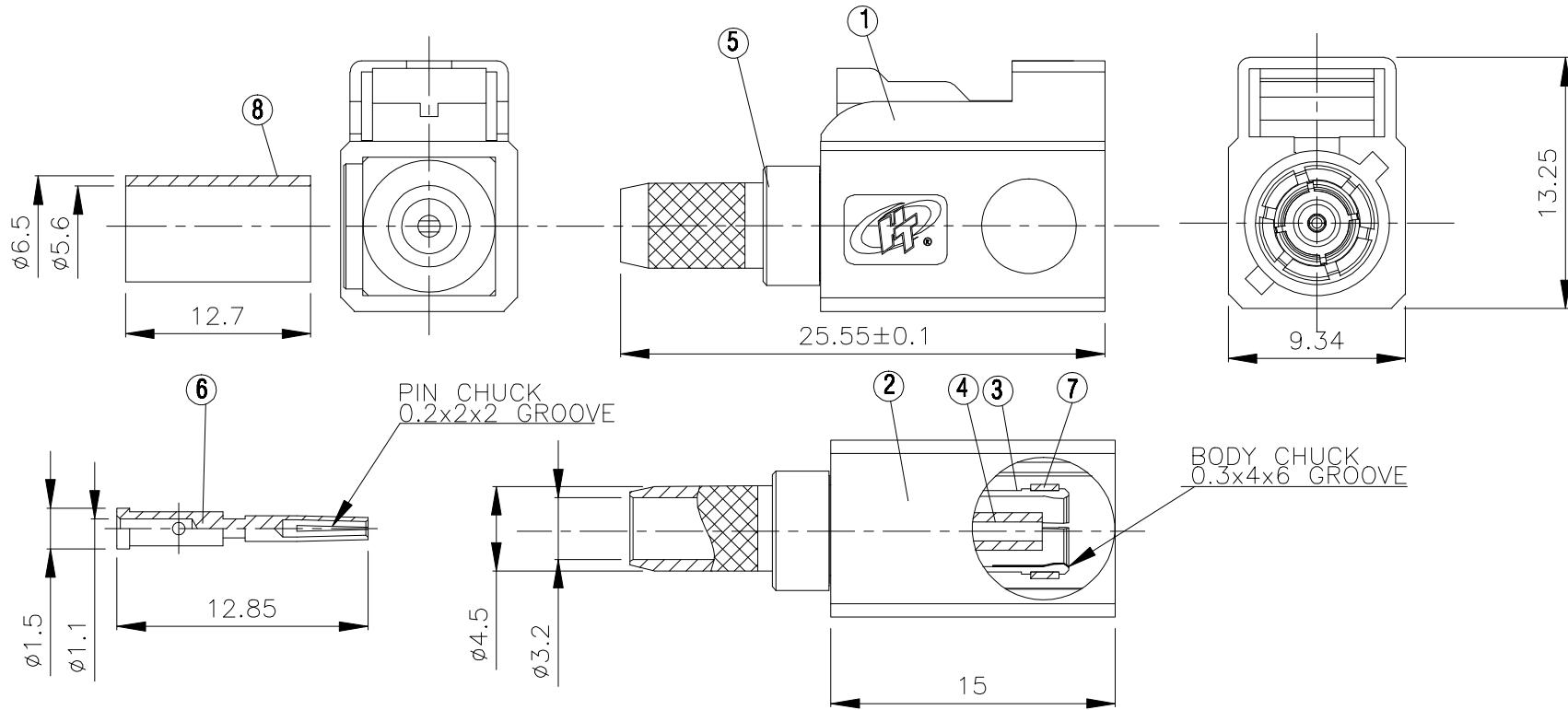

HUS-TSAN GROUP CO., LTD.

P.O.BOX 40-76.TAINAN.TAWAN,R.O.C.

TITLE SMB FEMALE CRIMP FOR RG-58/U

PART NO. FKR-10F-TGNPC

DRAWING NO. FKR 10F TGNPC

DRAWN 蘇姿潔 DATE 98.05.11

CHECKED 蘇志欣 DATE

Q.A. 林妙樺 DATE

APPROVAL 徐燦霖 DATE

REVISION DATE

DIMENSIONS ARE IN MILLIMETERS

UNLESS OTHERWISE SPECIFIED TOLERANCE

0.5-5=±0.2 120-315=±1

5-30=±0.4 315-1000=±1.6

30-120±0.6 1000-2000=±2.4

SCALE 4:1 SIZE A

REVISION

DESCRIPTION ENGINEER

D

D

C

C

B

B

A

A

4

3

2

1