

Recommended P.C.B. Layout(Top View)
(PCB Board Tolerance ± 0.05)

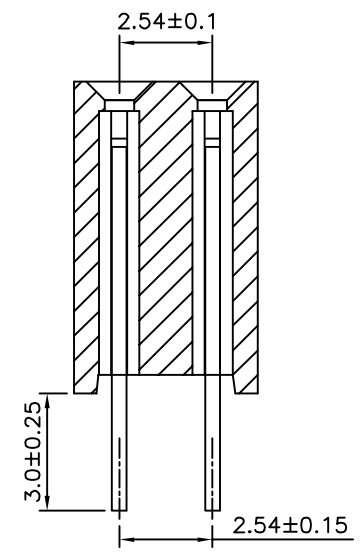
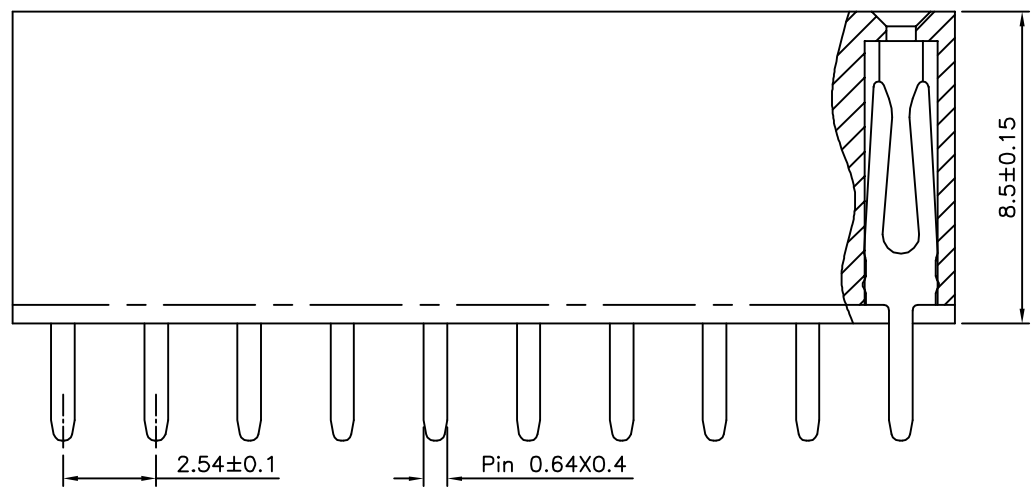
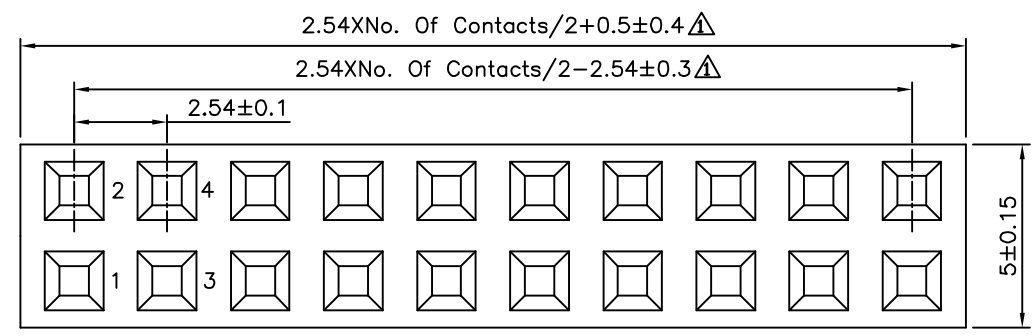

SPECIFICATION

Current Rating:3 Amps
 Δ Withstanding Voltage:1000V AC
 Contact Resistance:20 Milliohms Max.
 Insulation Resistance:1000 Megaohms Min.
 Operation Temperature:-40°C~+105°C
 Housing:PA6T(UL94V-0),Black
 Contact:Brass,Gold Flash Over Nickel
 RoHS Compliant

F D 2 X XX - H H
 (1) (2) (3) (4) (5) (6)

- (1) F:2.54mm Female Header
- (2) D:DIP Straight
- (3) 2: Dual Row
- (4) XX:No. Of Position/Per Row
- (5) H:Withstand High Temperature Soldering
- (6) H:RoHS Compliant

AUK A MEMBER OF AUK GROUP
太聯事業股份有限公司
AUK CONTRACTORS CO., LTD.

CATEGORY		APPROVED BY	
PART No. FD2XXX-HH		EMILY	
DRAWING No. FD2XXX-HH		CHECKED BY HZF	
SCALE NONE		DRAWING BY SAN	
REV. A1		UNIT mm	

UNLESS OTHERWISE SPECIFIED TOLERANCES ARE			
X ±0.25	X' ±2°		
.X ±0.20	.X' ±1.5°		
.XX ±0.15	.XX' ±1°	Δ A1	Modify Data
.XXX ±0.10	.XXX' ±0.5°	Δ A0	NEW RELEASE
NO. REV.	REVISIONS	CHK	DATE