

4

3

2

1

NO	DESCRIPTION	MATERIAL	Q'TY	FINISH
1	BODY 1	BRASS	1	NICKEL
2	BODY 2	BRASS	1	NICKEL

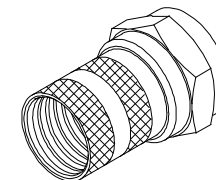

D

D

C

C

B

B

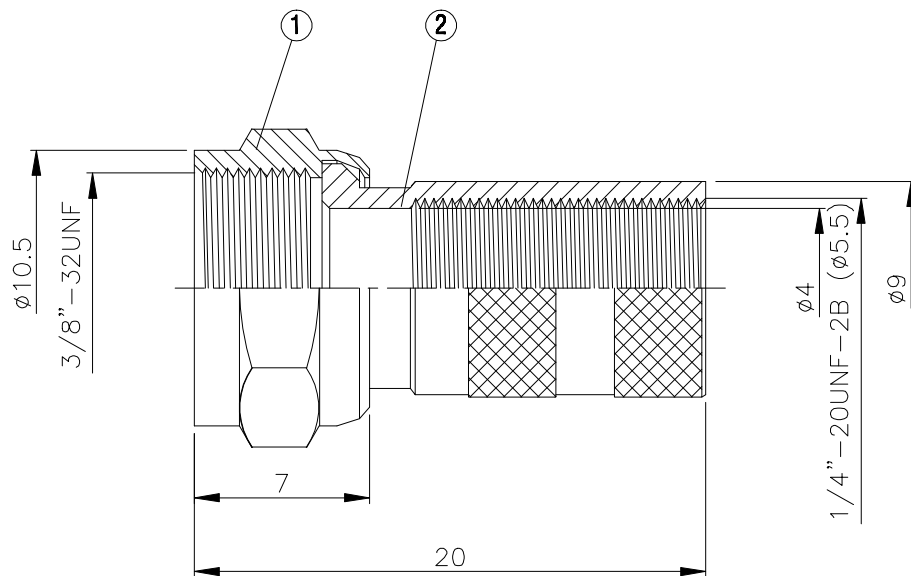
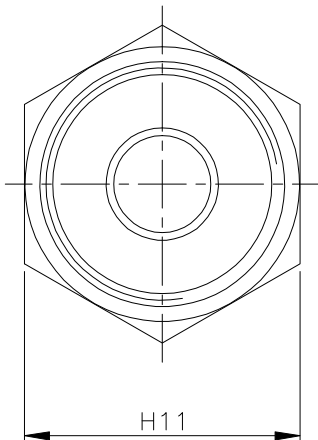

A

A

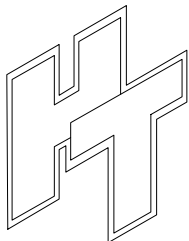

HUS-TSAN GROUP CO., LTD.

P.O. BOX 40-76. TAINAN. TAIWAN, R.O.C.

TITLE F MALE TWIST FOR RG59/U

PART NO. F-09G-NICKEL

DRAWING NO. F 09G NICKEL

DRAWN	MARY	DATE	88.06.25
CHECKED	黃巧君	DATE	96.02.07
Q.A.	蘇姿潔	DATE	
APPROVAL	徐燦霖	DATE	
REVISION		DATE	

DIMENSIONS ARE IN MILLIMETERS

UNLESS OTHERWISE SPECIFIED TOLERANCE

0.5-5=±0.2	120-315=±1
5-30=±0.4	315-1000=±1.6
30-120=±0.6	1000-2000=±2.4

SCALE 5:1 SIZE A

REVISION

DESCRIPTION ENGINEER

4

3

2

1