

未注公差/General tolerances(mm)											0.1/10		
0	>3	>6	>10	>18	>30	>50	>80	>120	>180	>250		>315	>400
~3	~6	~10	~18	~30	~50	~80	~120	~180	~250	~315	~400	~500	>500
±0.12	±0.18	±0.22	±0.26	±0.31	±0.37	±0.57	±0.80	±0.93	±1.05	±1.15	±1.60	±2.20	±2.50
													±2'

A

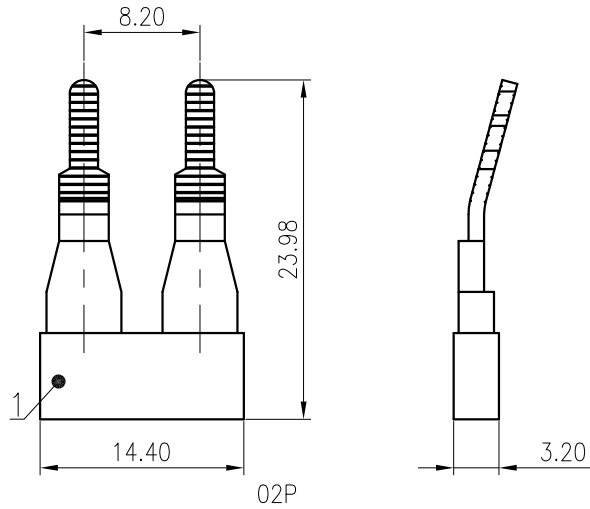

02P

B

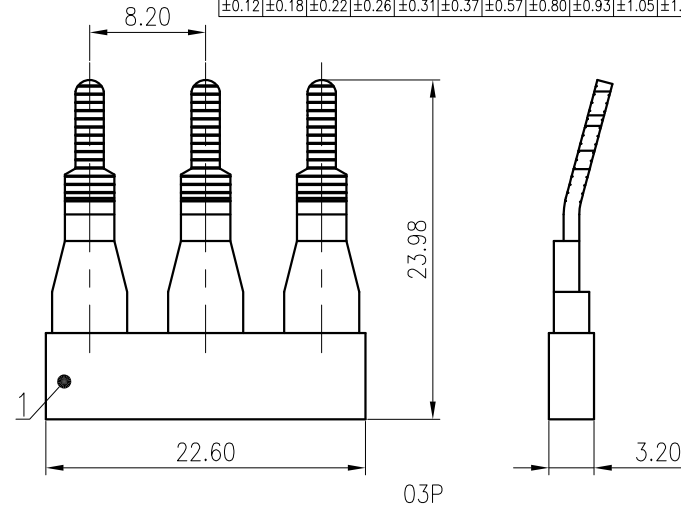

03P

A

B

C

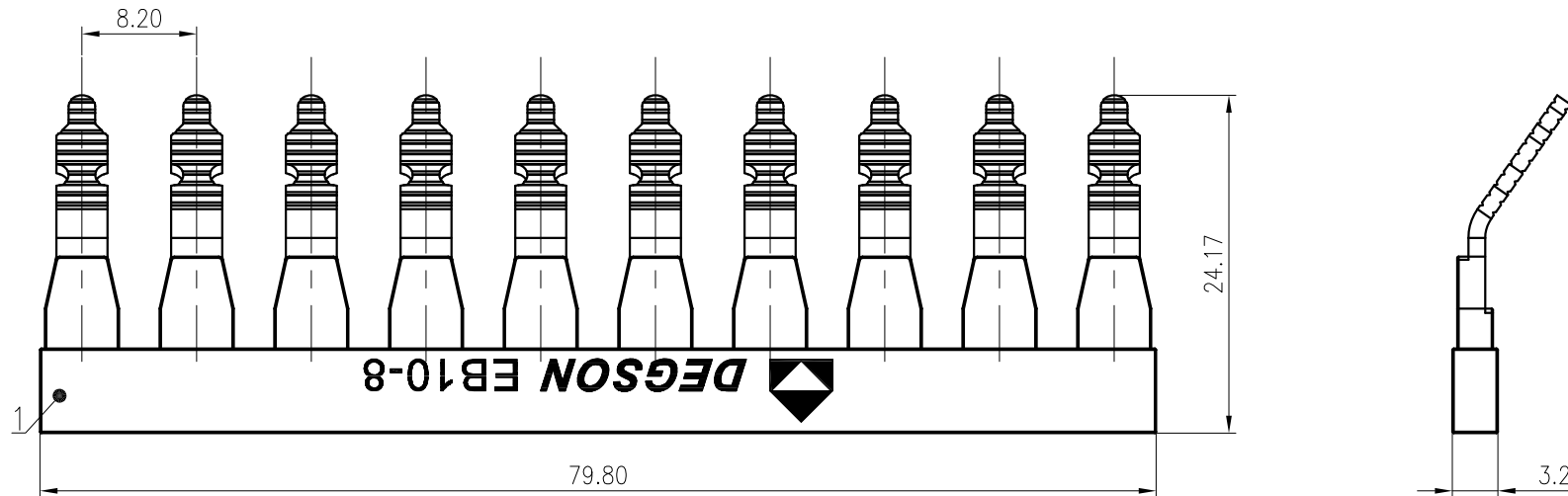

79.80

24.17

3.26

DEGSON EB10-8

10P

Material of Pins/Poles: Brass, plating SnCe
Material of Housing: PA66 UL94V-0
Rated voltage 600 volts

EB10-8-1Y-00AH
EB10-8 - series (for 10 Pins/Poles)
1 - single-row
Y - color of Housing (1 - gray color)
00AH - no value

MATERIAL: /	SURFACE: /	
MAT NO.: /	宁波高松电子有限公司 NINGBO DEGSON ELECTRICAL CO., LTD	
STATUS: /		
APPD:	NAME: EBXX-8-1Y-00A(H)	
CHKD:	DRAWING NO.: EBXX-8-C01	
DRFT: Chen K 2020.06.03	REV	T0
SIZE: A4	TYPE: CUSTOMER DRAWING	SCALE: 2:1 SHEET 1/1

1	Bridge		
ITEM	NAME OF PART	MATERIAL	NOTES
	间距/Pitch(mm)/线数范围/Poles	8.2/N=02P,03P,10P	
	使用温度范围/Operating temperature(°C)	-40~+105	
	符合RoHS环保要求/Conform to RoHS	Yes	

REV	ECN	DESCRIPTION	DRFT	DATE

D

D