

P/No.: DS1152-01-01PV8W8T-ELTECH-048

REV.	DESCRIPTION	DRAWN	CHECKED	APPROVED
A	NEW RELEASE	JLZ 12/15/21'		

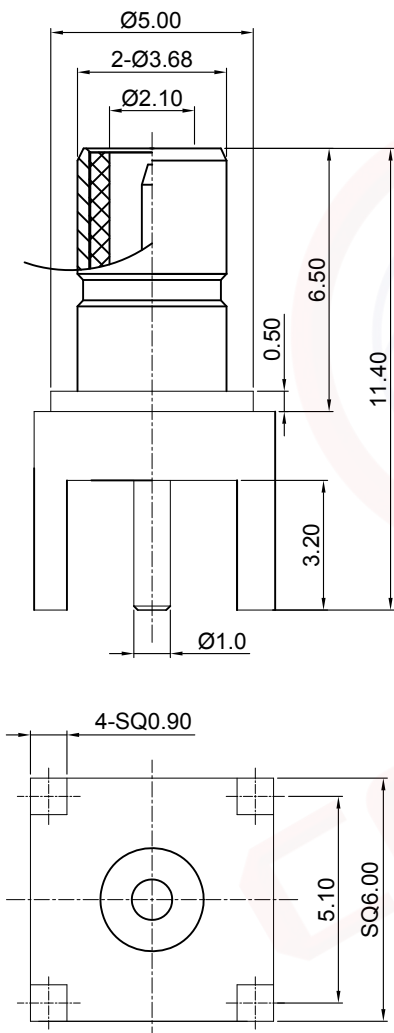

Notes:

1. Materials:

- 1.1. Contact: Copper Alloy, Full Gold Flash Plated.
- 1.2. Shell: Copper Alloy, Full Gold Flash Plated.
- 1.3. Insulator: PTFE.

2. Specifications:

- 2.1. Contact Resistance: 10mΩ max.
- 2.2. Insulation Resistance: 1000MΩ min.
- 2.3. Dielectric Withstanding Voltage: 1000V min.
- 2.4. Temperature Range: -40~+200°C.
- 2.5. Impedance: 50Ω.
- 2.6. Operating Cycles: 400 Cycles min.

3. Packing Type: Tray.

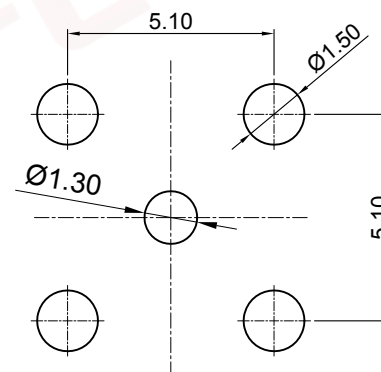

Recommend PCB Layout
Tolerance=±0.05mm

GENERAL TOLERANCE		ANGLE TOLERANCE		PROJECTION		TITLE	SMB Connector Male Vertical Through Type L=11.4mm	
X.	±0.60	X.	±5°	UNITS	mm			
.X	±0.38	.X	±3°	SHEET SIZE	A4	SERIES	DS1152-01 SERIES	
.XX	±0.25	.XX	±2°	晨翔电子有限公司 CONNFLY CONNFLY ELECTRONIC CO. LTD				
DRAWING TYPE		CUSTOMER						
SCALE	1:1	SHEET	1 OF 1					
DRAWING NO.		C-DS1152-01-01PV8W8T-ELTECH-048-A						

The information provided herein is from CONNFLY Electronic Co., Ltd. and is confidential. Any disclosure to a party other than the recipient is prohibited. The intellectual properties and its rights of CONNFLY Electronic Co., Ltd. are reserved. All rights are reserved. CONNFLY Electronic Co., Ltd. does not constitute, authorize, or endorse any use of its name or logo for any purpose other than its own. CONNFLY may enforce its intellectual property rights at its own discretion; failures or delays to exercise such rights does not constitute a waiver of such rights.