

| REV. | DESCRIPTION | DRAWN | CHECKED | APPROVED |
|------|----------------|---------------|---------------|---------------|
| A | NEW RELEASE | YCH 06/20/12' | ~ | JLZ 06/20/12' |
| B | DRAWING UPDATE | JLZ 12/10/16' | HZW 12/10/16' | LJC 12/10/16' |
| C | DRAWING UPDATE | JLZ 06/26/17' | ~ | |

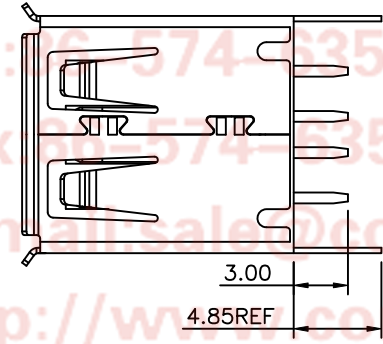

BEND TYPE →

STRAIGHT TYPE →

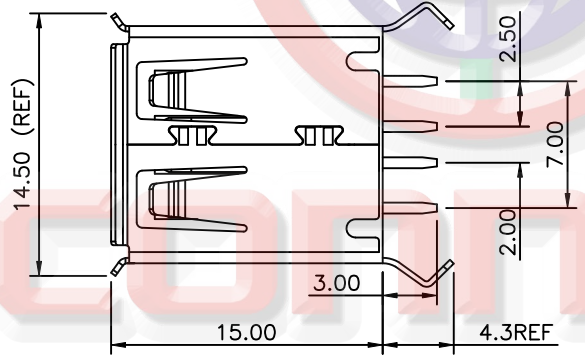
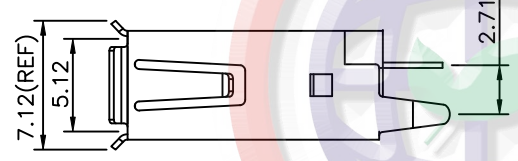
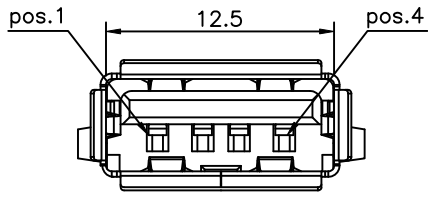
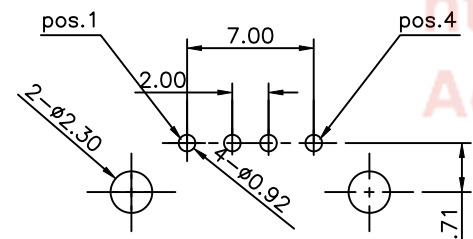

RECOMMEND PCB LAYOUT
(TOLERANCE=±0.05)

NOTES:

- SPECIFICATIONS:
 - CONTACT RESISTANCE: 30mΩ max.
 - INSULATOR RESISTANCE: 1000MΩ min.AT DC 500V.
 - CURRENT RATING: 1.5A.
 - VOLTAGE RATING: 30V AC/DC.
 - DIELECTRIC STRENGTH: AC 500V FOR 1 Minute.
- MATERIALS:
 - HOUSING: PBT+30% GLASS FIBER(UL 94-0).
 - CONTACT: COPPER ALLOY
 - SHELL: COPPER ALLOY OR STEEL.
- PRODUCT NUMBER CODE:

DS1095-10-X X X X - X

- SHELL MATERIALS
Fe: Steel
N/A: Copper Alloy
- CONTACT PLATING
0: Selective gold flash
03: Selective gold 3u"
30: Selective gold 30u"
- BOARDLOCK TYPE
S: Straight type
B: Bend type
- SHELL PLATING:
N: Nickel
6: Tin
- COLOR OF HOUSING:
W: White
B: Black

| GENERAL TOLERANCE | | ANGLE TOLERANCE | |
|-------------------|-------|-----------------|-----|
| X. | ±0.60 | X. | ±5° |
| .X | ±0.38 | .X | ±3° |
| .XX | ±0.25 | .XX | ±2° |

| PROJECTION | TITLE |
|---|------------------|
| UNITS | mm |
| SHEET SIZE | A4 |
| TITLE: USB A/F180° TYPE Single port Female TYPE | |
| SERIES | DS1095-10 SERIES |

| DRAWING TYPE | CUSTOMER |
|--------------|----------------------|
| SCALE | 1:1 SHEET 1 OF 1 |
| DRAWING NO. | C-DS1095-10-XXXX-X-C |

晨翔电子有限公司
CONNFLY CONNFLY ELECTRONIC CO. LTD

Tel: 86-574-83508787
 Fax: 86-574-83510817
 E-mail: sales@connfly.com
<http://www.connfly.com>
 Add: East Industry Zone KuangYan
 Town Cixi Ningbo China
 P.C: 315333